







# CONTENT

|   |     |
|---|-----|
| CHAPTER 1 INSTALLATION.....                                 | 7   |
| CHAPTER 2 BASIC CONFIGURATION.....                          | 8   |
| CHAPTER 3 WIRING.....                                       | 12  |
| CHAPTER 4 KEYBOARD.....                                     | 16  |
| CHAPTER 5 COMMON BASIC PARAMETERS.....                      | 20  |
| CHAPTER 6 FUNCTION PARAMETERS.....                          | 26  |
| CHAPTER 7 APPLICATION MACRO EXAMPLES.....                   | 117 |
| CHAPTER 8 RS485 COMMUNICATION.....                          | 164 |
| CHAPTER 9 FAULT RESOLUTION AND REPAIR.....                  | 172 |
| CHAPTER 10 TECHNICAL NOTES.....                             | 175 |
| CHAPTER 11 SELECTION OF BRAKING RESISTOR.....               | 176 |
| CHAPTER 12 DIMENSIONS.....                                  | 180 |
| CHAPTER 13 QUICK PARAMETER CONFIGURATION TABLE.....         | 181 |
| CHAPTER 14 STANDARD CARD (H10001) INSTRUCTIONS FOR USE..... | 184 |

## Safety Precautions

- Always observe safety precautions to prevent accidents and potential hazards.
  - In this manual, the safety information is classified as below:
    -  **WARNING** Fault operation may result in serious personal injury or death
    -  **CAUTION** Fault operation may result personal injury or property damage from minor to moderate class.
    - In this manual, the following signs are used as safety precautions::
      -  Under certain conditions, identify dangers that cause personal injury.
      - 1) Since dangerous voltages may exist, special attention should be paid.
    -  Under certain conditions, identify potential hazards.
- Read the information carefully and follow the instructions.  
For convenience, please save it nearby.  
Read this manual carefully to optimize the performance of H1 series inverter and ensure safe use.

### Warning

Do not open the casing in case of electric shock when the power supply has been supplied or the inverter is in the running state,  
Do not operate the inverter when the front-cover of the inverter is opening. In case of shocked by high voltage or exposed charging capacitors.  
Do not open the inverter's casing except for periodic inspection or wiring,, even if the inverter is not connected to input voltage. In case of get an electric shock from the charging circuit.  
Wiring and periodic maintain should be performed after removing the input power and using the instrument to discharge the DC voltage (below DC 30V) for at least 10 minutes. In case of electric shock.  
Start the switch with dry hands in case of get an electric shock.  
Do not use cables with damaged insulation in case of an electric shock.  
Do not make the cable to scratches, pinch, overvoltage or overload in case of an electric shock.

### Notes

The inverter should be installed on a non-flammable surface, and do not place flammable materials nearby.  
Otherwise, a fire may occur.  
If the inverter is damaged, immediately disconnect the input power in case of cause secondary damage to the equipment or fire.  
After the input power is disconnected, the residual heat of the inverter will remain for several minutes. Do not touch it. Otherwise, you may be physically injured (for example: skin burns or injuries).  
Do not power on the inverter that is damaged or missing parts, even if the installation has been completed.  
Otherwise, electric shock may occur.  
Burlap, paper dust, wood dust, dust, metal fragments or other miscellaneous objects are not allowed to enter the inverter. Otherwise, fire or accident may occur.

## Operational precautions

- (1) Maintenance and installation
- Handle according to the weight of the product.
  - The number of stacked inverter packaging boxes should not exceed the specified number.

## H1 series vector control inverter manual V1.0

- Installation according to the instructions in this manual.
- Do not open the casing during delivery.
- Do not place heavy objects on the inverter.
- Check if the inverter's packing direction is correct.
- Do not drop or squeeze the inverter.
- For 200V inverters, use category 3 grounding method (grounding resistance <math><100\Omega</math>), for 400V inverters (grounding resistance <math><10\Omega</math>)
- H1 series contains ESD (electrostatic discharge) sensitive parts. When inspecting or installing, be careful to take protective measures (electrostatic discharge) before touching the printed circuit board.
- Use the inverter under the following environmental conditions.

Table 0-1: Environmental conditions

|                                   |                            |   |
|-----------------------------------|----------------------------|---|
| <b>Env<br/>iro<br/>nm<br/>ent</b> | <b>Temperature</b>         | -10°C ~ +40°C (Ambient temperature is 40 °C ~ 50 °C, please use derating)   |
|                                   | <b>Humidity</b>            | 5%~95%RH, No condensation   |
|                                   | <b>Storage temperature</b> | -40°C ~ +70°C   |
|                                   | <b>Installation site</b>   | Indoor, no direct sunlight, no dust, corrosive gas, flammable gas, oil mist, water vapor, dripping water or salt etc. |
|                                   | <b>Altitude</b>            | For derating above 1000 meters, derate 10% for every 1000 meters  |
|                                   | <b>Vibration</b>           | Less than 5.9 m / s <sup>2</sup> (0.6g)   |

### (2) Wiring

Do not install power capacitors, surge suppressors, or RFI filters on the output side of the inverter.

The connection method of the output cables (U, V, W) connected to the motor will affect the rotation direction of the motor.

Incorrect terminal wiring may cause damage to the device.

If the positive and negative poles of the terminals are reversed, the inverter may be damaged.

Only personnel who are familiar with the H1 inverter can wire and inspect the inverter.

Install the inverter before wiring, otherwise, you may get an electric shock or personal injury.

### (3) Trial operation

Check all parameters before operation and modify the parameter values according to the load type.

Always use within the voltage range in this manual, otherwise the inverter may be damaged.

### (4) Operation prevention

When the automatic restart function is selected, since the motor will restart suddenly after the fault stops, it should be away from the device.

The "STOP" key on the operation keyboard is only effective when the corresponding function settings have been set, and special circumstances should be prepared for emergency stop switch.

If the fault reset is set using external terminals, a sudden start will occur. Please check in advance whether the external terminal signal is in the off position, in case of an accident may occur.

Do not modify or change anything inside the inverter.

The electronic thermal protection function of the inverter may not protect the motor.

## H1 series vector control inverter manual V1.0

Do not use electromagnetic AC contactor as the switch for frequent start and stop of the inverter on the input side of the inverter.

Use a noise filter to reduce the influence of electromagnetic interference generated by the inverter, in case of nearby electronic equipment may be interfered.

If the input voltage is unbalanced, an AC reactor needs to be installed. The potential higher harmonics from the inverter may cause the power capacitor and generator to become hot or damaged.

After the parameters are initialized, the parameter values are restored to the factory settings, and the parameters need to be set again before running.

The inverter can be easily set to high-speed operation. Check the capacity of the motor or mechanical equipment before operation.

When the DC braking function is used, there will be no stopping torque. When it is necessary to stop the torque, install a separate device.

When driving 400V inverters and motors, use insulated rectifiers and take measures to suppress surge voltage. The surge voltage caused by the wiring constant problem at the motor terminals may damage the insulation and damage the motor.

### (5) Accident prevention

Prepare a safety device, such as an emergency braking device, to prevent the use of machinery and equipment in a more dangerous environment if the inverter has problems.

### (6) Maintenance, inspection and parts replacement

Do not test the control circuit of the inverter (insulation resistance measurement) with a high resistance meter.

Regular inspection.

### (7) Disposal

Disposal as industrial waste after broken.

### (8) General notes

Most charts or drawings in this manual indicate that if the inverter is not equipped with a circuit breaker, enclosure or partial open circuit, the inverter must never be operated. When operating the inverter, always install the enclosure and circuit breaker, and observe the regulations in the installation manual.

## H1series nameplate

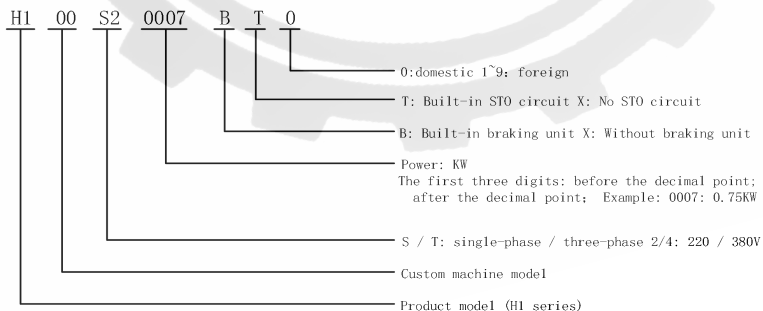

## H1series specification

# H1 series vector control inverter manual V1.0

| Framer NO. | Model         | Input voltage     | Input current (A) | Rated power (KW) | Output current (A) | Motor (KW) |
|------------|---------------|-------------------|-------------------|------------------|--------------------|------------|
| F1         | H100S20007BX0 | Single-phase 220V | 8.2               | 0.75             | 5.0                | 0.75       |
|            | H100S20015BX0 | Single-phase 220V | 14.0              | 1.5              | 7.0                | 1.5        |
| F2         | H100T20022BX0 | Single-phase 220V | 23.0              | 2.2              | 12.5               | 2.2        |
|            |               | Three phase 220V  | 13.5              |                  |                    |            |
| F3         | H100T20037BX0 | Single-phase 220V | 38.6              | 3.7              | 15.2               | 3.7        |
|            |               | Three phase 220V  | 16.5              |                  |                    |            |
|            | H100T20055BX0 | Three phase 220V  | 24                | 5.5              | 23                 | 5.5        |
| F4         | H100T20075BX0 | Three phase 220V  | 37                | 7.5              | 31                 | 7.5        |
|            | H100T20110BX0 | Three phase 220V  | 52                | 11               | 45                 | 11         |

## H1 series vector control inverter manual V1.0

|    |                   |                        |      |      |      |      |
|----|-------------------|------------------------|------|------|------|------|
| F1 | H100T4000<br>7BX0 | Three<br>phase<br>380V | 4.0  | 0.75 | 3.0  | 0.75 |
|    | H100T4001<br>5BX0 | Three<br>phase<br>380V | 5.8  | 1.5  | 4.5  | 1.5  |
|    | H100T4002<br>2BX0 | Three<br>phase<br>380V | 6.5  | 2.2  | 5.6  | 2.2  |
| F2 | H100T4004<br>0BX0 | Three<br>phase<br>380V | 12.6 | 4.0  | 10.5 | 4.0  |
| F3 | H100T4005<br>5BX0 | Three<br>phase<br>380V | 16   | 5.5  | 14   | 5.5  |
|    | H100T4007<br>5BX0 | Three<br>phase<br>380V | 21   | 7.5  | 19   | 7.5  |
| F4 | H100T4011<br>0BX0 | Three<br>phase<br>380V | 28   | 11   | 26   | 11   |
|    | H100T4015<br>0BX0 | Three<br>phase<br>380V | 36   | 15   | 33   | 15   |
| F5 | H100T4018<br>5BX0 | Three<br>phase<br>380V | 42   | 18.5 | 40   | 18.5 |
|    | H100T4022<br>0BX0 | Three<br>phase<br>380V | 48   | 22   | 46   | 22   |

# HYPER INVERTER

## Chapter 1 Installation

### 1.1 Installation prevention



#### Warning

- The inverter uses plastic parts, so be careful not to damage it. Do not grab the front keyboard to move the inverter in case of fall.
- The inverter is installed without vibration ( $5.9 \text{ m/s}^2$  or less).
- Install the inverter within the allowable temperature range ( $-10 \sim 50\text{C}$ ).
- The temperature of the inverter during operation is very high, and the inverter needs to be installed on a non-flammable surface.
- Install the inverter on smooth, vertical and horizontal surfaces. The direction of the inverter must be vertical for heat dissipation. At the same time, leave enough space around the inverter.

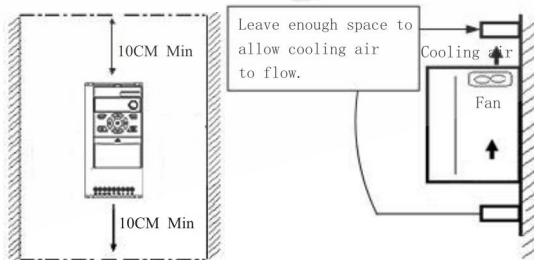

Chart 1-1 Installation instructions

- Avoid moisture and direct sunlight.
- Do not install the inverter in places with oil gas, flammable gas and dust. Install the inverter in a clean place or in a closed plate that isolates foreign materials.
- When two or more inverters are installed on one space, the inverter or cooling fan must be installed in a suitable location to ensure that the surrounding temperature is within the allowable range.
- When installing the inverter, use screws for fixing to ensure that the inverter is firmly installed.

## Chapter 2 Basic Configuration

### 2.1 Outside equipment connection

The following equipment is required to operate the inverter. Select appropriate outside equipment and connect it correctly to ensure normal operation. Fault application or installation of the inverter may cause system failure or reduce product life and damage components. Before proceeding, you must read and fully understand the manual.

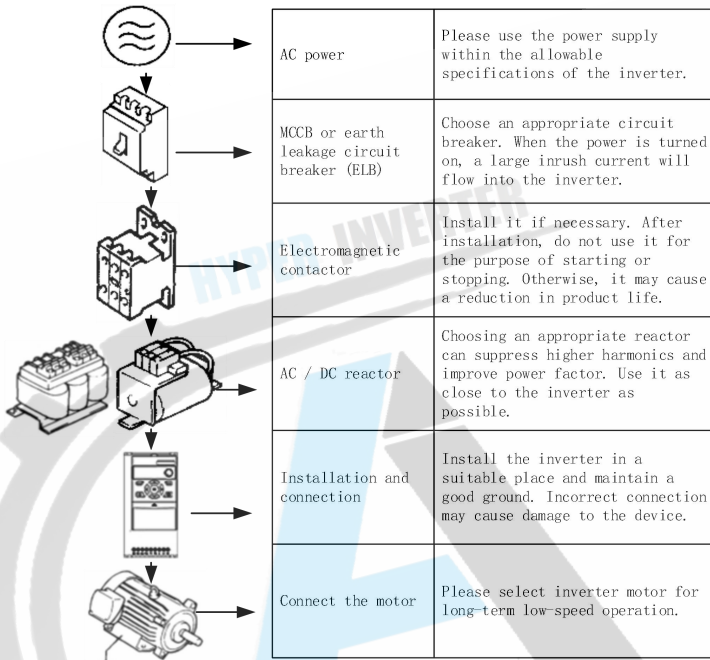

Chart 2-1 Diagram connection of outside equipments and inverter

## 2.2 List of main circuit applicable devices and their electrical specifications

| Voltage class (V) | Inverter rated power | Motor (KW) | Inverter input   |                 | Recommended wiring size (mm <sup>2</sup> ) |            |                 |                                       |  |
|-------------------|----------------------|------------|------------------|-----------------|--|------------|-----------------|---------------------------------------|--|
|                   |                      |            | Air-switch model | Contactor model | Power line (input / output)                | DC reactor | Braking circuit | Control signal wire (external wiring) |  |
|                   |                      |            |                  |                 |  |            |                 |                                       |  |

H1 series vector control inverter manual V1.0

| )       | (K<br>W) |      |                   |             | line)   |     |     |          |
|---------|----------|------|-------------------|-------------|---------|-----|-----|----------|
| 22<br>0 | 0.75     | 0.75 | DZ20-100(<br>16A) | CJ20-<br>16 | 2<br>.5 | 4   | 2.5 | 0.5~0.75 |
|         | 1.5      | 1.5  |                   |             |         |     |     |          |
|         | 2.2      | 2.2  | DZ20-100(<br>32A) | CJ20-<br>40 | 4       | 6   | 4   |          |
|         | 3.7      | 3.7  |                   |             |         |     |     |          |
|         | 5.5      | 5.5  | DZ20-100(<br>32A) | CJ20-<br>40 | 4       | 6   | 4   |          |
|         | 7.5      | 7.5  | DZ20-100(<br>50A) | CJ20-<br>40 | 6       | 6   | 4   |          |
|         | 11       | 11   | DZ20-100(<br>63A) | CJ20-<br>63 | 8       | 8   | 6   |          |
| 38<br>0 | 0.75     | 0.75 | DZ20-100(<br>16A) | CJ20-<br>16 | 1.5     | 4   | 1.5 |          |
|         | 1.5      | 1.5  |                   |             |         |     |     |          |
|         | 2.2      | 2.2  |                   |             |         | 2.5 | 2.5 |          |
|         | 4.0      | 4.0  |                   |             |         |     |     |          |
|         | 5.5      | 5.5  | DZ20-100(<br>32A) | CJ20-<br>25 | 4       | 6   | 4   |          |
|         | 7.5      | 7.5  |                   |             |         |     |     |          |
|         | 11       | 11   | DZ20-100(<br>50A) | CJ20-<br>40 | 6       | 8   |     |          |
|         | 15       | 15   |                   |             | 8       |     |     |          |
|         | 18.5     | 18.5 |                   |             |         |     |     |          |
|         |          |      |                   |             |         |     |     |          |

## H1 series vector control inverter manual V1.0

|  |    |    |                   |             |    |    |   |  |
|--|----|----|-------------------|-------------|----|----|---|--|
|  | 22 | 22 | DZ20-100(<br>63A) | CJ20-<br>63 | 10 | 16 | 6 |  |
|--|----|----|-------------------|-------------|----|----|---|--|



## Chapter 3 Wiring

### 3.1 Main circuit and function card

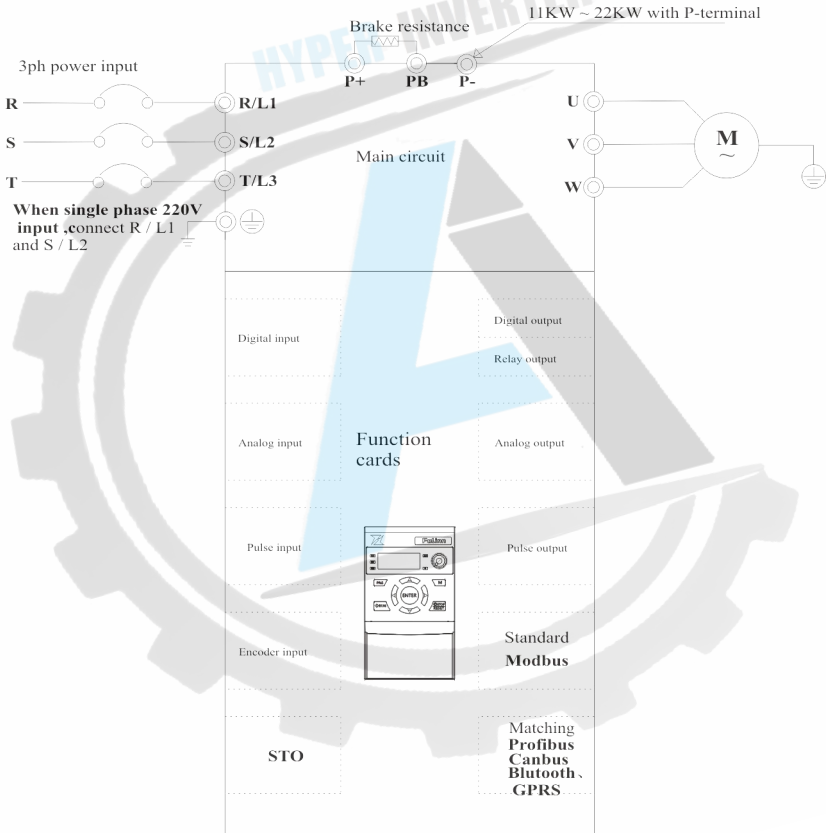

Chart 3-1 Main circuit and function card

**Note:** Different function cards connect to different terminals. In addition to standard function cards, any type of card can be customized. When using different function cards, the parameters need to be reset.



**Warning:** It is strictly forbidden to plug and unplug the function card with power

### 3.2 Power terminal wiring instructions



#### Warning

For 220V class inverter, use class 3 grounding method (grounding resistance: less than 100).

For 380V class inverter, use class 3 grounding method (grounding resistance: less than 10).

Use special grounding terminal for grounding. Do not use screws for grounding in the box.

Note: Grounding steps

(1) Determine the location of the ground terminal.

(2) Connect the ground-wire to the ground terminal and make sure that the screws are tight.

### 3.3 Main circuit terminal description

| Terminal symbol | Terminal name                     | Function description  |
|-----------------|-----------------------------------|---|
|                 | Ground terminal                   | Inverter safety ground  |
| R/L1、S/L2、T/L3  | Main circuit power input terminal | Connect three-phase power, single-phase power to R / L1, S / L2         |
| P+、PB           | Brake terminal                    | Connect external braking resistor                                       |
| P+、P-           | DC bus terminal                   | when two or more inverters share a DC bus (11KW ~ 22KW have P-terminal) |
| U、V、W           | Inverter output terminal          | Connect a three-phase motor   |

Please implement the wiring in accordance with the regulations of electrician regulations to ensure safety. When selection of the wire diameter specification, it is best to use isolated wires or conduits for power wiring, and ground the isolation layer or conduits at both ends.

Be sure to install the air disconnect switch NFB between the power supply and the input terminals (R / L1, S / L2, T / L2)

Do not connect the AC power supply to the output terminal (U V W) of the inverter.

The output wiring must not touch the metal shell of the inverter, in case of a short circuit to ground.

Do not use phase shift capacitors, LC / RC noise filters and other components at the output of the inverter.

The main circuit wiring of the inverter must be far away from other control equipment.

When the wiring between the inverter and the motor exceeds 15 meters (220V level), (380V level 30 meters), a high dV / dT will be generated inside the motor coil, which will produce interlayer insulation of the motor then damaged, please use a special motor for the inverter or install a reactor on the inverter side.

#### Ground wire:

Please correctly ground the grounding wire terminal PE:

220V level: The 3 class grounding (grounding resistance below 100).

## H1 series vector control inverter manual V1.0

380V: Special 3 class grounding (grounding resistance below 10).

For the use of the ground wire, please follow the basic length and size of the electrical equipment technology.

Use special grounding terminal for grounding. Do not use screws for grounding in the box. Absolutely avoid public grounding with large power equipment such as welding machines, power machinery, etc. The ground wire should be as far away as possible from the ground wire of large power equipment.

The ground wiring must be as short as possible.

**Note:** Grounding steps

- (1) Remove the front keyboard.
- (2) Connect the ground wire to the ground terminal and ensure that the screws are tight.

### 3.4 The Parameter table of function card

| Function card  | H1 | H2 | H3 | H4 | H5 | H6 | H7 | H8 | H9 | H0 | H1 | H2 |
|----------------|----|----|----|----|----|----|----|----|----|----|----|----|
|                | 0  | 0  | 0  | 0  | 0  | 0  | 0  | 0  | 0  | 0  | 1  | 1  |
| Features       | 1  | 2  | 3  | 4  | 5  | 6  | 7  | 8  | 9  | 0  | 1  | 2  |
| Digital input  | 4  | 3  | 4  | 8  | 2  | 2  | 3  | 2  | 2  | 4  | 4  | 3  |
| Digital output |    |    |    |    |    |    |    | 4  | 4  |    |    |    |
| Relay output   | 1  |    | 3  | 1  | 1  | 1  | 1  | 1  | 1  | 1  | 1  | 1  |
| Analog input   | 1  |    | 1  |    | 2  |    |    | 1  | 1  | 1  | 1  | 1  |
| Analog output  |    |    |    |    | 2  |    |    | 1  | 1  |    |    |    |
| Pulse input    |    |    |    |    |    | 1  |    |    |    |    |    |    |
| Pulse output   |    |    |    |    |    | 1  |    |    |    |    |    |    |
| Encoder input  |    |    |    |    |    |    | 1  |    |    |    |    |    |
| MODBU          | 1  | 1  | 1  | 1  | 1  | 1  | 1  | 1  | 1  | 1  | 1  | 1  |



## Chapter 4 Keyboard

### 4.1 Keyboard Features

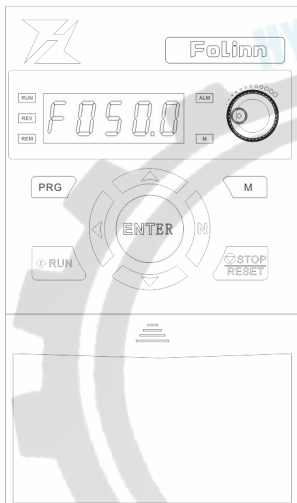

| NO. | Construction | Function explain   |
|-----|--------------|--|
| 1   |              | Display  |
| 2   |              | Programming / Exit key   |
| 3   |              | The status display interface is the status switching key, the other interface is the left shift key              |
| 4   |              | Reserved key   |
| 5   |              | Run key  |
| 6   |              | Potentiometer: see parameter P1.63   |
| 7   |              | In programming mode, value change key  |
| 8   |              | In non-programming mode, increasing and decreasing (UP / DOWN) selection key. See parameters P1.63, P2.03, P2.04 |
| 9   |              | Enter  |
| 10  |              | Stop/reset   |
| 11  |              | Customized key   |

| Indicator light | State          | Function Detail    |
|-----------------|----------------|--------------------|
| RUN             | Bright / flash | Running/Decelerate |
| REV             | Bright         | Reversing          |
| REM             | Bright         | Remote start       |

|     |        |   |
|-----|--------|---|
| ALM | Bright | Fault indication  |
| M   | Bright | Customer customized instructions, fault alarm instructions, see parameters P1.66 and P1.67. |

## 4.2 Keyboard operation

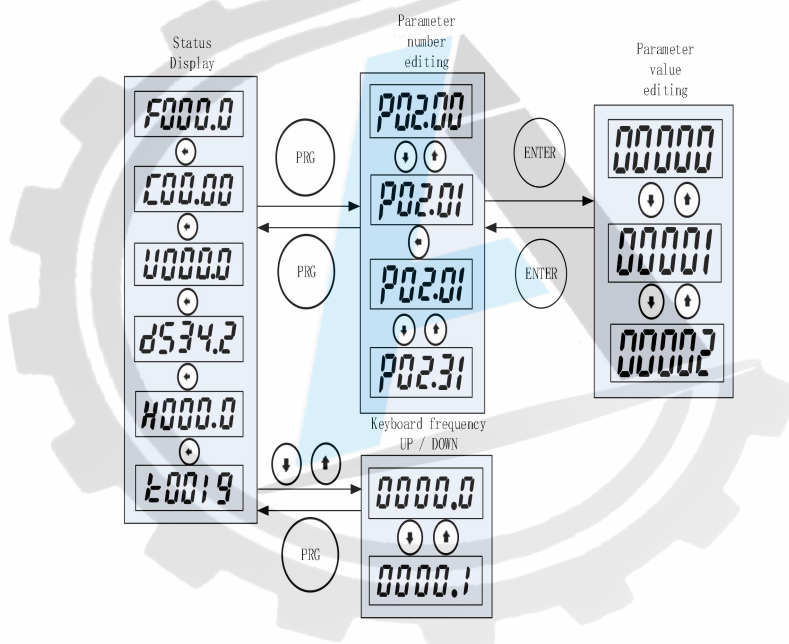

| Item | Description      |
|------|------------------|
| $F$  | Output frequency |
| $C$  | Output current   |

|   |                                     |
|---|-------------------------------------|
| U | Output voltage                      |
| d | Bus voltage                         |
| H | Display value 1 (selected by P1.68) |
| k | Display value 2 (selected by P1.69) |
| A | Alarm                               |
| E | Fault                               |

### 4.3 Character display

|   |   |   |   |   |   |
|---|---|---|---|---|---|
| 0 | 0 | A | K | U | L |
| 1 | 1 | E | L | U | V |
| 2 | 2 | C | N | U | V |
| 3 | 3 | D | N | 5 | X |
| 4 | 4 | E | C | 4 | Y |
| 5 | 5 | F | F | 1 | Z |
| 6 | 6 | C | C |   |   |
| 7 | 7 | H | F |   |   |
| 8 | 8 | I | S |   |   |

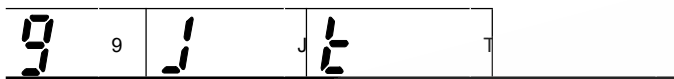

## Chapter 5 Common basic parameters

### Note:

Some parameters have been set at the factory (factory value), and do not be set for the first use.

### 5.1 Set the motor rated parameters

After power on, use the operation keyboard to set the parameters as the following table. According to the motor-nameplate for motor parameters.

| Parameter number | Function        | Parameter number | Function      |
|------------------|-----------------|------------------|---------------|
| P6.11            | Motor power     | P6.14            | Motor current |
| P6.12            | Motor Voltage   | P6.15            | Motor speed   |
| P6.13            | Motor frequency |                  |               |

### 5.2 Use the keyboard to control the start and stop and the keyboard potentiometer to set the operating frequency

#### 5.2.1 Power on.

Use the operation keyboard to set the motor parameters (P6.11 ~ P6.15), keyboard potentiometer to control speed and acceleration / deceleration time (P2.50, P2.70).

| Parameter number | Function                        | Set value           | Detail   |
|------------------|---------------------------------|---------------------|--|
| P1.63            | The source of keyboard settings | 1 ( Factory Value ) | The operating frequency is set by the keyboard potentiometer |
| P2.10            | Set point source                | 0 ( Factory Value ) | The operating frequency is set by the keyboard               |
| P3.00            | Start command source            | 1 ( Factory Value ) | Operation keyboard to run command channel                    |
| P3.04            | Source of stop command          | 1                   | Operation keyboard to stop command channel                   |
| P2.50            | Acceleration time               | -                   | The acceleration time is adjusted according to actual needs  |
| P2.70            | Deceleration time               | -                   | Deceleration time is adjusted according to actual needs      |

5.2.2 Press the RUN key on the operation keyboard to start the inverter, rotate the potentiometer on the keyboard to adjust the set frequency, and press the STOP key to stop the inverter output.

### 5.3 Use terminal to control start and stop and keyboard to set operating frequency

5.3.1 Terminal S1 is for forward signal input, and S2 is for reverse signal input. The wiring is

as shown in the figure below.

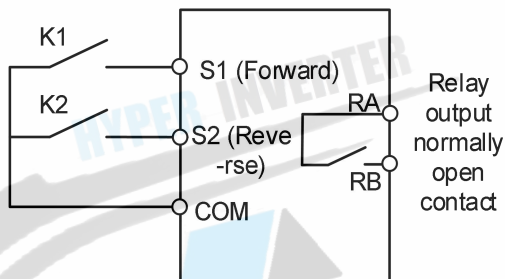

5.3.2 Power on, then set the function parameters according to the wiring diagram, see the table as below.

| Parameter number | Function                               | Set value           | Detail  |
|------------------|--|---------------------|---|
| P1.63            | Keyboard settings source               | 0                   | Keyboard setting source is set by P2.92 number                    |
| P2.03            | Source of incremental instruction (UP) | 1                   | Incremental command (UP) source keyboard                          |
| P2.04            | Decrement Instruction (DOWN)           | 1                   | Decrease command (DOWN) source keyboard                           |
| P2.10            | Set value source 1                     | 0 ( Factory value ) | The operating frequency is set by the keyboard                    |
| P2.92            | Keyboard settings                      | -                   | Operating frequency, relative to P2.18 percentage                 |
| P2.50            | Acceleration time 0                    | -                   | The acceleration time is adjusted according to actual needs       |
| P2.70            | Deceleration time 0                    | -                   | Deceleration time is adjusted according to actual needs           |
| P3.00            | Start command source                   | 3                   | Forward running function (terminal forward rotation signal input) |
| P3.01            | Reverse start command source           | 4                   | Reverse running function (terminal reverse signal input)          |

5.3.3 When K1 in the wiring diagram is closed, the motor runs forward; when K1 is disconnected, the motor stops running. When K2 is closed, the motor runs in reverse; when K2 is disconnected, the motor stops running. When K1 and K2 are closed or opened at the same time, the motor stops running. You can increase / decrease the set frequency by ▲ ▼ the value of P2.92 or pressing and on the operation keyboard.

## 5.4 Use terminals to control start, stop and analog to set

### operating frequency

5.4.1 Terminal S1 is for forward signal input, and S2 is for reverse signal input. The wiring is shown in the figure below.

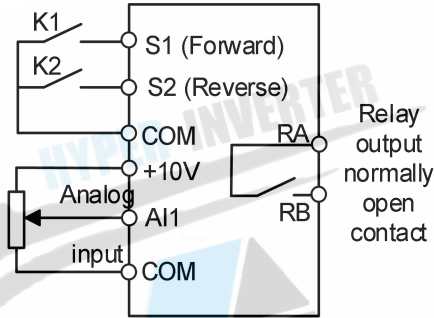

5.4.2 Power on, then set the function parameter table according to the wiring diagram, see the table below.

| Parameter number | Function                     | Set value | Detail   |
|------------------|------------------------------|-----------|--|
| P2.10            | Set value source 1           | 2         | The operating frequency is set by analog AI1                       |
| P2.50            | Acceleration time 0          | -         | The acceleration time is adjusted according to actual needs        |
| P2.70            | Deceleration time 0          | -         | Deceleration time is adjusted according to actual needs            |
| P3.00            | Start command source         | 3         | Forward rotation function (terminal forward rotation signal input) |
| P3.01            | Reverse start command source | 4         | Reverse function (terminal reverse signal input)                   |

5.4.3 Set the operating frequency by adjusting the AI1 analog input.

5.4.4 When K1 in the wiring diagram is closed, the motor runs forward; when K1 is disconnected, the motor stops running. When K2 is closed, the motor runs in reverse; when K2 is disconnected, the motor stops running. When K1 and K2 are closed or opened at the same time, the motor stops running.

### 5.5 Process control PID: Multi-step speed 0 is set value, AI1 is feedback value

5.5.1 Terminal S1 is the forward signal input, AI1 is the feedback signal input. The wiring is shown below.

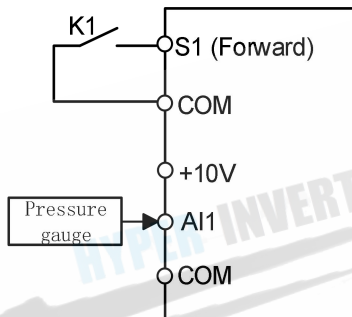

5.5.2 Power on, the function parameter table according to the diagram, see the below.

then set  
wiring  
table

| Parameter number | Function                             | Set value | Detail  |
|------------------|--------------------------------------|-----------|---|
| P2.10            | Set value source 1                   | 1         | PID set value selected multi-step speed 0: 100% of full scale     |
| P2.11            | Set value source 2                   | 2         | PID feedback selected analog AI1: 10V corresponds to full scale   |
| P2.13            | Set channel relationship             | 8         | Activate PID control  |
| P2.30            | Multi-speed 0                        | -         | PID set value   |
| P3.00            | Start command source                 | 3         | Select S1 as the source of the operation command                  |
| P4.00            | PID proportional gain                | -         | Set as required, the greater the value, the faster the adjustment |
| P4.01            | PID integration time                 | -         | Set as required, the smaller the value, the faster the adjustment |
| P1.68            | Keyboard H monitoring item selection | 1090      | Item H displays P10.90, which is the PID setting value            |
| P1.69            | Keyboard T monitoring item selection | 1091      | The T item shows P10.91 which is the PID feedback value           |

5.5.3 Adjust the P2.30 to get the desired pressure.

5.5.4 When K1 in the wiring diagram is closed, the system starts to run.

## 5.6 Use terminal to control start-stop and communication to set running frequency

## H1 series vector control inverter manual V1.0

5.6.1 Terminal S1 is for forward signal input and S2 is for reverse signal input. The wiring is as shown in the figure below.

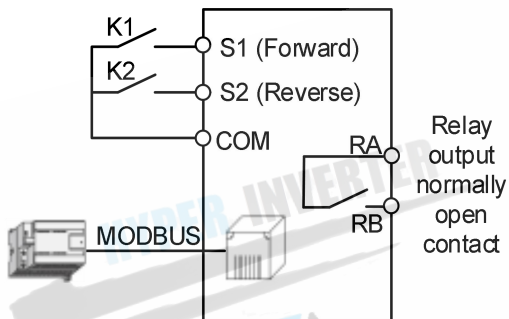

5.6.2 Power on, then set the function parameters according to the wiring diagram, see the table below.

| Parameter number | Function                     | Set value          | Detail   |
|------------------|------------------------------|--------------------|--|
| P1.40            | Protocol                     | 1 (Factory value)  | MODBUS RTU   |
| P1.41            | Local address                | 1 (Factory value)  | Slave address 1  |
| P1.42            | Baud rate                    | 3 (Factory value)  | 19200bps   |
| P1.43            | Parity check                 | 0 (Factory value)  | No check   |
| P1.44            | Data bit                     | 8 (Factory value)  | 8 bit  |
| P1.45            | Stop bit                     | 1.0(Factory value) | 1 bit  |
| P2.10            | Setpoint source 1            | 5                  | MODBUS communication settings                                      |
| P2.50            | Acceleration time 0          | -                  | The acceleration time is adjusted according to actual needs        |
| P2.70            | Deceleration time 0          | -                  | Deceleration time is adjusted according to actual needs            |
| P3.00            | Start command source         | 3                  | Forward rotation function (terminal forward rotation signal input) |
| P3.01            | Reverse start command source | 4                  | Reverse function (terminal reverse signal input)                   |

5.6.3 When K1 in the wiring diagram is closed, the motor runs forward; when K1 is disconnected, the motor stops running. When K2 is closed, the motor runs in reverse; when K2 is disconnected, the motor stops running. When K1 and K2 are closed or opened at the

same time, the motor stops running.

5.6.4 Modify the running frequency by writing register 0x0121 through MODBUS communication (function code 0x06). For example: modify the running frequency of slave address 1 to 25Hz, see the table below.

|               | Address | Function code | Register address |      | Register content |      | Sum of Check |      |
|---------------|---------|---------------|------------------|------|------------------|------|--------------|------|
| Request frame | 0x01    | 0x06          | 0x01             | 0x21 | 0xC3             | 0x50 | 0x88         | 0xF0 |
| Reply frame   | 0x01    | 0x06          | 0x01             | 0x21 | 0xC3             | 0x50 | 0x88         | 0xF0 |

## 5.7 Use communication to control start and stop and communication to set operating frequency

5.7.1 Connect the communication cable as shown below.

5.7.2 Power on, the function parameters according to the diagram, see the below.

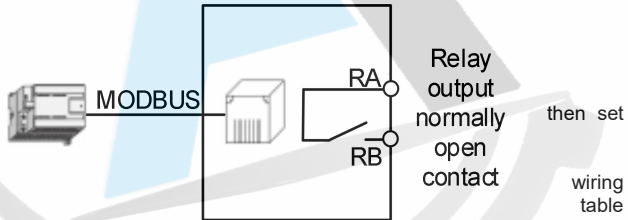

| Parameter number | Function            | Set value           | Detail  |
|------------------|---------------------|---------------------|---|
| P1.40            | Protocol            | 1 (Factory value)   | MODBUS RTU  |
| P1.41            | Local address       | 1 (Factory value)   | Slave address 1                                       |
| P1.42            | Baud rate           | 3 (Factory value)   | 19200bps  |
| P1.43            | Parity check        | 0 (Factory value)   | No check  |
| P1.44            | Data bit            | 8 (Factory value)   | 8 bit   |
| P1.45            | Stop bit            | 1.0 (Factory value) | 1bit  |
| P2.10            | Set value source 1  | 5                   | MODBUS communication setting frequency                |
| P2.50            | Acceleration time 0 | -                   | The acceleration time is adjusted according to actual |

|       |                        |   |   |
|-------|------------------------|---|---|
|       |                        |   | needs   |
| P2.70 | Deceleration time 0    | - | Deceleration time is adjusted according to actual needs |
| P3.00 | Start command source   | 2 | MODBUS communication starts                             |
| P3.04 | Source of stop command | 2 | MODBUS communication stopped                            |

5.7.3 Start or stop the inverter whose slave address 1 by writing register 0x0122 through MODBUS communication (function code 0x06).

Such as: start command, see the table below.

|               | Address | Function code | Register address |      | Register content |      | Check code |      |
|---------------|---------|---------------|------------------|------|------------------|------|------------|------|
|               |         |               | 0x01             | 0x22 | 0x00             | 0x01 | 0xE9       | 0xFC |
| Request frame | 0x01    | 0x06          | 0x01             | 0x22 | 0x00             | 0x01 | 0xE9       | 0xFC |
| Reply frame   | 0x01    | 0x06          | 0x01             | 0x22 | 0x00             | 0x01 | 0xE9       | 0xFC |

Such as: stop command, see the table below.

|               | Address | Function code | Register address |      | Register content |      | Check code |      |
|---------------|---------|---------------|------------------|------|------------------|------|------------|------|
|               |         |               | 0x01             | 0x22 | 0x00             | 0x10 | 0x29       | 0xF0 |
| Request frame | 0x01    | 0x06          | 0x01             | 0x22 | 0x00             | 0x10 | 0x29       | 0xF0 |
| Reply frame   | 0x01    | 0x06          | 0x01             | 0x22 | 0x00             | 0x10 | 0x29       | 0xF0 |

5.7.4 Modify the operating frequency by writing register 0x0121 through MODBUS communication (function code 0x06). For example: modify the running frequency of slave address 1 to 20Hz, see the table below.

|               | Address | Function code | Register address |      | Register content |      | Check code |      |
|---------------|---------|---------------|------------------|------|------------------|------|------------|------|
|               |         |               | 0x01             | 0x21 | 0x9C             | 0x40 | 0xB0       | 0xCC |
| Request frame | 0x01    | 0x06          | 0x01             | 0x21 | 0x9C             | 0x40 | 0xB0       | 0xCC |
| Reply frame   | 0x01    | 0x06          | 0x01             | 0x21 | 0x9C             | 0x40 | 0xB0       | 0xCC |

## Chapter 6 Function parameters

| Classif | Parameter | Function | Setting number | unit | Factory value |
|---------|-----------|----------|----------------|------|---------------|
|---------|-----------|----------|----------------|------|---------------|

H1 series vector control inverter manual V1.0

| y                         | number                  |  |  |      |     |
|---------------------------|-------------------------|--|--|------|-----|
| 01 :<br>System parameters | P1.11                   | Parameter operation  | 0: Normal Operation;<br>1: Parameter Initialization, initialization except P 1. XX and apply parameters other than macros;<br>2: initialize all parameters |      | 0   |
|                           | P1.13                   | Set keyword  | 0~9999   |      | 0   |
|                           | P1.14                   | Set keyword confirmed  | 0~9999   |      | 0   |
|                           | P1.15                   | Input keyword  | 0~9999   |      | 0   |
|                           | P1.20                   | Apply macro  | 0~9999   |      | 0   |
|                           | P1.21                   | Recipe   | 0~10000  |      | 0   |
|                           | P1.30                   | virtual terminal to set  | 0~199:Value setting;<br>200~9999:Address   |      | 0   |
|                           | P1.39                   | Command Mode   | 0:Single Command source mode;<br>1:Multi-command source mode   |      | 0   |
|                           | P1.40                   | Communication Protocol   | 0:Reserved;<br>1:MODBUS RTU;<br>2~6:Reserved   |      | 1   |
|                           | P1.41                   | Address  | 0~247  |      | 1   |
|                           | P1.42                   | Baud Rate  | 0:2400;<br>1:4800;<br>2:9600;<br>3:19200;<br>4:38400;<br>5~10:Reserved   | bps  | 3   |
|                           | P1.43                   | Parity Check   | 0:No Check;<br>1:Even check;<br>2:Odd check  |      | 0   |
|                           | P1.44                   | Data Bit   | 8~9  | Bits | 8   |
|                           | P1.45                   | Stop Bit   | 0.0~2.0  | Bit  | 1.0 |
|                           | P1.47                   | parameter decimal mode   | 0~123  |      | 0   |
|                           | P1.63                   | Keyboard settings source   | 0: Keyboard numeric setting (P2.92);<br>1: Keyboard potentiometer setting  |      | 1   |
| P1.66                     | keyboard M light Source | 0: always 0;<br>1: always 1;<br>2: stopped;<br>3: running;<br>4: fault;<br>5: Warning;<br>6: Reversing;<br>7: ready;<br>64: STO state; |  | 5    |     |

# H1 series vector control inverter manual V1.0

|                         |                              |  |  |       |        |
|-------------------------|------------------------------|--|--|-------|--------|
|                         |                              |  | 100 ~ 9999: address  |       |        |
|                         | P1.67                        | Keyboard M Lamp source Bit display     | 0~31   |       | 0      |
|                         | P1.68                        | value 1 source                         | 0~9999   |       | 1011   |
|                         | P1.69                        | value 2 source                         | 0~9999   |       | 1091   |
| 02 :<br>Setting channel | P2.00                        | Multi-speed source                     |  |       | 0      |
|                         | P2.01                        | Source of acceleration time            | 0~11111111<br>Units: S1;<br>Tens: S2;<br>Hundreds: S3;   |       | 0      |
|                         | P2.02                        | Source of deceleration time            | ...  |       | 0      |
|                         | P2.03                        | Source of incremental instruction (UP) | Units: keyboard;<br>Tens: communication;<br>Hundreds: S1;<br>Thousands: S2;<br>...             |       | 0      |
|                         | P2.04                        | Source of Decrement instruction (DOWN) | ...  |       | 0      |
|                         | P2.10                        | Set value source 1                     | 0: keyboard;<br>1: Multi-speed;  |       | 0      |
|                         | P2.11                        | Set value source 2                     | 2: AI1;<br>3: AI2;   |       | 0      |
|                         | P2.12                        | Setpoint source 3                      | 5: communication;<br>9: pulse input<br>200 ~ 9999: address                                     |       | 0      |
|                         | P2.13                        | Set channel 1 relationship selection   | 0:F1;<br>1:F2;<br>2:F1+F2;<br>3:F1-F2;<br>4:F1*F2/100;   |       | 0      |
|                         | P2.14                        | Set channel 2 relationship selection   | 5:Maximum value(F1,F2);<br>6:Minimum value(F1,F2);<br>7:Average value(F1,F2);<br>8:PID(F1,F2); |       | 0      |
|                         | P2.18                        | Maximum setting                        | -99999.000~99999.000   |       | 50.000 |
|                         | P2.19                        | Minimum setting                        |  |       | 0.000  |
|                         | P2.20                        | Avoid-frequency 1 start point          |  |       |        |
| P2.21                   | Avoid-frequency 1 stop point | -1000.000~1000.000                     | %  | 0.000 |        |

# H1 series vector control inverter manual V1.0

|       |  |   |   |        |  |
|-------|--|---|---|--------|--|
| P2.22 | Avoid-frequency 2 start point                      |   |   |        |  |
| P2.23 | Avoid-frequency 2 stop point                       |   |   |        |  |
| P2.24 | Jog Frequency                                      | -1000.000~1000.000  | % | 10.000 |  |
| P2.26 | Increase and decrease (UP / DOWN) Step-frequency   | -100.0~100.0  | % | 0.2    |  |
| P2.27 | Increase and decrease (UP / DOWN) memory selection | 0: no memory;<br>1: Only power down memory;<br>2: Only stop memory;<br>3: Both power down and stop memory |   | 3      |  |
| P2.28 | Speed up and down frequency                        | -1000.000~1000.000  | % | 0.000  |  |
| P2.30 | Multi-speed 0                                      |   |   |        |  |
| P2.31 | Multi-speed 1                                      |   |   |        |  |
| P2.32 | Multi-speed 2                                      |   |   |        |  |
| P2.33 | Multi-speed 3                                      |   |   |        |  |
| P2.34 | Multi-speed 4                                      |   |   |        |  |
| P2.35 | Multi-speed 5                                      |   |   |        |  |
| P2.36 | Multi-speed 6                                      |   |   |        |  |
| P2.37 | Multi-speed 7                                      |   |   |        |  |
| P2.38 | Multi-speed 8                                      | -1000.000~1000.000  | % | 0.000  |  |
| P2.39 | Multi-speed 9                                      |   |   |        |  |
| P2.40 | Multi-speed 10                                     |   |   |        |  |
| P2.41 | Multi-speed 11                                     |   |   |        |  |
| P2.42 | Multi-speed 12                                     |   |   |        |  |
| P2.43 | Multi-speed 13                                     |   |   |        |  |
| P2.44 | Multi-speed 14                                     |   |   |        |  |
| P2.45 | Multi-speed 15                                     |   |   |        |  |
| P2.50 | Accelerate time 0                                  |   |   |        |  |
| P2.51 | Accelerate time 1                                  |   |   |        |  |
| P2.52 | Accelerate time 2                                  |   |   |        |  |
| P2.53 | Accelerate time 3                                  |   |   |        |  |
| P2.54 | Accelerate time 4                                  | 0.050~3600.000  | S | *      |  |
| P2.55 | Accelerate time 5                                  |   |   |        |  |
| P2.56 | Accelerate time 6                                  |   |   |        |  |
| P2.57 | Accelerate time 7                                  |   |   |        |  |

# H1 series vector control inverter manual V1.0

|       |                             |                |   |       |
|-------|-----------------------------|----------------|---|-------|
| P2.58 | Accelerate time 8           |                |   |       |
| P2.59 | Accelerate time 9           |                |   |       |
| P2.60 | Accelerate time 10          |                |   |       |
| P2.61 | Accelerate time 11          |                |   |       |
| P2.62 | Accelerate time 12          |                |   |       |
| P2.63 | Accelerate time 13          |                |   |       |
| P2.64 | Accelerate time 14          |                |   |       |
| P2.65 | Accelerate time 15          |                |   |       |
| P2.66 | Jog acceleration time       | 0.050~3600.000 | S | 5.000 |
| P2.68 | S curve acceleration time 1 | 0.000~100.000  | % | 0.000 |
| P2.69 | S curve acceleration time 2 |                |   |       |
| P2.70 | Deceleration time 0         | 0.050~3600.000 | S | *     |
| P2.71 | Deceleration time 1         |                |   |       |
| P2.72 | Deceleration time 2         |                |   |       |
| P2.73 | Deceleration time 3         |                |   |       |
| P2.74 | Deceleration time 4         |                |   |       |
| P2.75 | Deceleration time 5         |                |   |       |
| P2.76 | Deceleration time 6         |                |   |       |
| P2.77 | Deceleration time 7         |                |   |       |
| P2.78 | Deceleration time 8         |                |   |       |
| P2.79 | Deceleration time 9         |                |   |       |
| P2.80 | Deceleration time 10        |                |   |       |
| P2.81 | Deceleration time 11        |                |   |       |
| P2.82 | Deceleration time 12        |                |   |       |
| P2.83 | Deceleration time 13        |                |   |       |

# H1 series vector control inverter manual V1.0

|       |                          |                              |  |  |         |   |
|-------|--------------------------|------------------------------|--|--|---------|---|
|       | P2.84                    | Deceleration time 14         |  |  |         |   |
|       | P2.85                    | Deceleration time 15         |  |  |         |   |
|       | P2.86                    | Jog deceleration time        | 0.050~3600.000   | S  | 5.000   |   |
|       | P2.87                    | Safe deceleration time       | 0.050~3600.000   | S  | 5.000   |   |
|       | P2.88                    | S curve deceleration time 1  | 0.000~100.000  | %  | 0.000   |   |
|       | P2.89                    | S curve deceleration time 2  |  |  |         |   |
|       | P2.90                    | Communication set value      | -1000.000~1000.000   | %  | 0.000   |   |
|       | P2.91                    | Communication demand         | 0~4294967295   |  | 0       |   |
|       | P2.92                    | Keyboard set value           | -1000.000~1000.000   | %  | 100.000 |   |
|       | P2.93                    | Keyboard demand              | 0~4294967295   |  | 0       |   |
|       | 03<br>: Input and output | P3.00                        | Start command source   | Bit16 ~ Bit31: Bits 0 ~ 15 of P1.30<br>0 ~ 4294967295<br>Single command source mode (P1.39 = 0):<br>0: No effect;<br>1: keyboard;<br>2: communication;<br>3: S1;<br>4: S2<br>...<br>17 ~ 32: The 0 ~ 15 bits of P1.30<br>Multi-command source mode (P1.39 = 1):<br>Bit0: keyboard;<br>Bit1: communication;<br>Bit2: S1;<br>Bit3: S2;<br>...; |         | 1 |
| P3.01 |                          | Reverse start command source | 0  |  |         |   |
| P3.02 |                          | Reverse command source       | 0  |  |         |   |
| P3.03 |                          | Jog command source           | 1  |  |         |   |
| P3.04 |                          | Source of stop command       | 0  |  |         |   |
| P3.05 |                          | Free parking order source    | 0  |  |         |   |
| P3.06 |                          | Source of Safe Stop Command  | 0  |  |         |   |
| P3.07 |                          | Reset command source         | 1  |  |         |   |
| P3.08 |                          | Source of fault command      | 0  |  |         |   |
| P3.09 |                          | Source of pause order        | 0  |  |         |   |
| P3.20 |                          | S1 type                      | 0: positive logic;<br>1: Reverse logic;<br>2: Rising edge;<br>3: Falling edge; |  |         |   |
| P3.21 | S2 type                  |                              |  |  |         |   |
| P3.22 | S3 type                  |                              |  |  |         |   |
| P3.23 | S4 type                  |                              |  |  |         |   |

|  |       |                                      |   |   |       |
|--|-------|--------------------------------------|---|---|-------|
|  | P3.24 | S5 type                              |   |   |       |
|  | P3.25 | S6 type                              |   |   |       |
|  | P3.26 | S7 type                              |   |   |       |
|  | P3.27 | S8 type                              |   |   |       |
|  | P3.28 | S Input filtering                    | 1~16  |   | 2     |
|  | P3.29 | Start signal enable mode             | 0: always enabled;<br>1: need to re-enable after power on;<br>2: After free-stop or safe-stop, it needs to be re-enabled;<br>3: After power-on, free stop or safe stop, you need to re-enable |   | 0     |
|  | P3.30 | Y1 terminal source(RA、RB or RA1、RB1) | 0: Always 0;<br>1: Always 1;<br>2: Stopped;<br>3: Running;<br>4: Fault;<br>5: Warning;<br>6: Reversing;<br>7: Ready;<br>64: STO state;<br>100 ~ 9999: address                                 |   | 3     |
|  | P3.31 | Y1 terminal source Bit               | 0~31  |   | 0     |
|  | P3.32 | Y2 terminal source (RA2、RB2)         | 0: Always 0;<br>1: Always 1;<br>2: Stopped;<br>3: Running;<br>4: Fault;<br>5: Warning;<br>6: Reversing;<br>7: Ready;<br>64: STO state;<br>100 ~ 9999: address                                 |   | 4     |
|  | P3.33 | Y2 terminal source bit               | 0~31  |   | 0     |
|  | P3.34 | Y3 terminal source (RA3、RB3、RC3)     | 0: Always 0;<br>1: Always 1;<br>2: Stopped;<br>3: Running;<br>4: Fault;<br>5: Warning;<br>6: Reversing;<br>7: Ready;<br>64: STO state;<br>100 ~ 9999: address                                 |   | 5     |
|  | P3.35 | Y3 terminal source Bit               | 0~31  |   | 0     |
|  | P3.36 | Y1 output delay                      | 0.000~6000.000  | S | 0.000 |

# H1 series vector control inverter manual V1.0

|       |     |                            |  |       |         |
|-------|-----|----------------------------|--|-------|---------|
|       |     | time                       |  |       |         |
| P3.37 | Y2  | output delay time          |  |       |         |
| P3.38 | Y3  | output delay time          |  |       |         |
| P3.39 | AI  | filter time                | 0.100~600.000  | S     | 0.100   |
| P3.40 | AI1 | signal type                | 0: voltage input;<br>1: current input  |       | 0       |
| P3.41 | AI1 | low-end voltage (current)  | -999999.000~999999.000   | V(mA) | 0.000   |
| P3.42 | AI1 | high-end voltage (current) |  |       | 10.000  |
| P3.43 | AI1 | low-end setting            | -999999.000~999999.000   | %     | 0.000   |
| P3.44 | AI1 | high-end setting           |  |       | 100.000 |
| P3.45 | AI2 | signal type                | 0: voltage input;<br>1: current input  |       | 0       |
| P3.46 | AI2 | low-end voltage (current)  | -999999.000~999999.000   | V(mA) | 0.000   |
| P3.47 | AI2 | high-end voltage (current) |  |       | 10.000  |
| P3.48 | AI2 | low-end setting            | -999999.000~999999.000   | %     | 0.000   |
| P3.49 | AI2 | high-end setting           |  |       | 100.000 |
| P3.60 | AO1 | signal type                | 0: voltage output;<br>1: current output  |       | 0       |
| P3.61 | AO1 | signal source              | 0: always 0;<br>1: Always 10V / 20mA;<br>2: Output frequency;<br>3: Motor current;<br>4: Output voltage;<br>5: Motor torque;<br><br>6: Output power;<br>7: Set frequency;<br>100 ~ 9999: quote the value of the parameter number |       | 2       |
| P3.62 | AO1 | low-end setting            | -999999.000~999999.000   | %     | 0.000   |
| P3.63 | AO1 | high-end settings          |  |       | 50.000  |
| P3.64 | AO1 | low-end voltage (current)  | -999999.000~999999.000   | V(mA) | 0.000   |
| P3.65 | AO1 | high-end voltage (current) |  |       | 10.000  |
| P3.66 | AO2 | signal type                | 0: voltage output;<br>1: current output  |       | 0       |

# H1 series vector control inverter manual V1.0

|                                   |       |                                  |  |       |         |
|-----------------------------------|-------|----------------------------------|--|-------|---------|
|                                   | P3.67 | AO1 signal source                | 0: always 0;<br>1: Always 10V / 20mA;<br>2: Output frequency;<br>3: Motor current;<br>4: Output voltage;<br>5: Motor torque;<br><br>6: Output power;<br>7: Set frequency;<br>100 ~ 9999: quote the value of the parameter number |       | 3       |
|                                   | P3.68 | AO2 low-end setting              | -999999.000~999999.000   | %     | 0.000   |
|                                   | P3.69 | AO2 high-end settings            |  |       | 50.000  |
|                                   | P3.70 | AO2 low-end voltage (current)    | -999999.000~999999.000   | V(mA) | 0.000   |
|                                   | P3.71 | AO2 high-end voltage (current)   |  |       | 10.000  |
| 04<br>:<br>P<br>I<br>D<br>control | P4.00 | PID proportional gain            | 0.000~10.000   | %     | 0.010   |
|                                   | P4.01 | PID integration time             | 0.001~9999.000   | S     | 10.000  |
|                                   | P4.02 | PID differential gain            | 0.000~9999.000   | %     | 0.000   |
|                                   | P4.03 | PID forward feedback coefficient | 0~500  | %     | 0       |
|                                   | P4.04 | PID sampling time                | 0.001~9999.000   | S     | 0.004   |
|                                   | P4.05 | PID output upper limit           | -1000.000~1000.000   | %     | 100.000 |
|                                   | P4.06 | PID output lower limit           |  | %     | 0.000   |
|                                   | P4.07 | PID output filter time           | 0.000~600.000  | S     | 0.000   |
|                                   | P4.09 | PID range                        | 0.001~99999.000  |       | 100.000 |
|                                   | P4.11 | PID sleep frequency              | 0.000~500.000  | %     | 0.000   |
|                                   | P4.12 | PID enters sleep time            | 0.000~3600.000   | S     | 0.000   |
|                                   | P4.13 | PID wake-up deviation            | 0.000~100.000  | %     | 0.000   |
|                                   | P4.14 | PID entry wake-up time           | 0.000~3600.000   | S     | 0.000   |
|                                   | P4.15 | PID sleep action                 | 0: do not sleep;<br>1: PID stop;<br>2: Slow down;<br>3: Free to stop;<br>4: Pause;<br>5: Lowest frequency  |       | 0       |

# H1 series vector control inverter manual V1.0

|                              |                                      |  |  |        |         |
|------------------------------|--------------------------------------|--|--|--------|---------|
|                              |                                      |  | operation  |        |         |
|                              | P4.90                                | PID status                               | 0~4294967295   |        |         |
| 05<br>:<br>System<br>control | P5.00                                | Control mode                             | 0: VF;<br>1: Open loop vector 1  |        | 1       |
|                              | P5.06                                | Forward and reverse switching time       | 0.000~6000.000   | S      | 0.000   |
|                              | P5.07                                | Forced change direction                  | 0: No effect;<br>1: forced change direction                            |        | 0       |
|                              | P5.08                                | Motor frequency upper limit              | -1020.000~1020.000   | Hz     | 55.000  |
|                              | P5.10                                | Start function                           | 0: Start frequency operation;<br>1: On speed start;<br>2: DC injection |        | 0       |
|                              | P5.11                                | Start Time                               | 0.000~60000.000  | S      | 0.000   |
|                              | P5.12                                | Start frequency                          | 0.000~100.000  | Hz     | 0.000   |
|                              | P5.14                                | On speed start mode                      | 0: All directional;<br>1: Set value direction;<br>2~3: reserved        |        | 0       |
|                              | P5.19                                | DC injection current                     | 0.000~200.000  | %      | 100.000 |
|                              | P5.20                                | Stop function                            | Units: 0: free parking;<br>1: DC braking;<br>Ten: 1: precise parking   |        | 0       |
|                              | P5.21                                | Stop frequency                           | 0.000~1000.000   | Hz     | 0.000   |
|                              | P5.22                                | DC braking current                       | 0.000~150.000  | %      | 100.000 |
|                              | P5.23                                | DC braking time                          | 0.000~1000.000   | S      | 0.000   |
|                              | P5.24                                | Demagnetization time ratio               | 0.000~1000.000   | %      | 10.000  |
|                              | P5.26                                | Magnetic flux brake activation frequency | 0.000~1000.000   | Hz     | 0.000   |
|                              | P5.27                                | Magnetic Flux braking coefficient        | 100~200  | %      | 100     |
|                              | P5.28                                | Magnetic Flux braking time               | 0.000~1000.000   | S      | 0.000   |
| P5.30                        | Brake resistance mode                | 0: invalid;<br>1: Maximum duty cycle;    |  | 1      |         |
| P5.50                        | Auto reset mode                      | 0~9999                                   |  | 0      |         |
| P5.51                        | Auto reset time                      | 0.000~600.000                            | S  | 10.000 |         |
| P5.60                        | Automatic energy saving minimum flux | 30~100                                   | %  | 100    |         |

|                                |       |   |  |     |         |
|--------------------------------|-------|---|--|-----|---------|
|                                | P5.61 | Automatic energy saving start frequency   | 0.000~200.000  | Hz  | 5.000   |
|                                | P5.63 | Manual energy-saving magnetic flux        | 30~90  | %   | 70      |
|                                | P5.71 | Current limit                             | 0~300  | %   | 150     |
|                                | P5.76 | Upper limit of electric torque            | 0.000~900.000  | %   | 150.000 |
|                                | P5.77 | Upper limit of regenerative torque        | 0.000~900.000  | %   | 150.000 |
|                                | P5.80 | Over-voltage control                      | 0: invalid;<br>1: valid at all times   |     | 1       |
|                                | P5.82 | Over-voltage control scale factor         | 0~200  | %   | 100     |
|                                | P5.83 | Over-voltage control integral coefficient | 1~10000  | %   | 100     |
|                                | P5.85 | Under-voltage control                     | Units: grid power-down action mode<br>0: invalid;<br>1: Instant stop;<br>2: Safe parking;<br>3 ~ 6: reserved<br>Tens: Under-voltage operation mode of power grid<br>0: invalid;<br>1: Safe frequency reduction |     | 0       |
|                                | P5.86 | Power grid voltage level                  | 100~800  | V   | *       |
|                                | P5.90 | AVR function selection                    | 0: invalid;<br>1: valid;<br>2: Only invalid when decelerating  |     | 1       |
|                                | P5.91 | AVR function damping factor               | 0~400  | %   | 100     |
| 06 :<br>Mot<br>or<br>mod<br>el | P6.00 | Motor parameter self-learning             | 0: invalid<br>1: Complete self-learning<br>2: Simple self-learning   |     | 0       |
|                                | P6.05 | Carrier frequency                         | 2~16   | kHz | *       |
|                                | P6.06 | Over-modulation function                  | 0: invalid; 1: valid   |     | 1       |
|                                | P6.10 | Motor type                                | 0: Asynchronous motor;<br>1: Surface mount permanent magnet synchronization;<br>2: Salient pole permanent magnet synchronization<br>4: single-phase motor  |     | 0       |
|                                | P6.11 | Motor Power                               | 0.000~100000.000   | kW  | *       |

# H1 series vector control inverter manual V1.0

|       |  |   |          |       |
|-------|--|---|----------|-------|
| P6.12 | Motor voltage                              | 0~1000  | V        | *     |
| P6.13 | Motor frequency                            | 1~3000  | Hz       | *     |
| P6.14 | Motor current                              | 0.00~1000.00  | A        | *     |
| P6.15 | Motor speed                                | 10~65535  | rpm      | *     |
| P6.16 | Motor power factor                         | 0.00~1.00   |          | *     |
| P6.17 | Number of motor poles                      | 2~100   |          | *     |
| P6.18 | Motor rated torque                         | 0.1~10000.0   | NM       | *     |
| P6.19 | Motor no-load current                      | 0.00~1000.00  | A        | *     |
| P6.20 | PM motor back EMF / rev                    | 1.000~1000.000  | mV/rpm   | *     |
| P6.40 | Stator impedance                           | 0.000~99.990  | $\Omega$ | *     |
| P6.41 | Rotor impedance                            | 0.000~99.990  | $\Omega$ | *     |
| P6.42 | Stator leakage reactance                   | 0.000~999.990   | mH       | *     |
| P6.44 | Motor main reactance                       | 0.00~999.90   | mH       | *     |
| P6.50 | PM d-axis reactance                        | 0.000~1000.000  | mH       | *     |
| P6.51 | PM q-axis reactance                        | 0.001~9999.000  | mH       | *     |
| P6.52 | PM d-axis reactance saturation coefficient | 0.0~100.0   | %        | *     |
| P6.53 | PM q axis reactance saturation coefficient | 0.0~100.0   | %        | *     |
| P6.54 | PM d-axis reactance saturation coefficient | 10~400  | %        | 100   |
| P6.55 | PM q axis reactance saturation coefficient | 10~400  | %        | 100   |
| P6.60 | Maximum field weakening current d          | 0.200 ~ 1.800   |          | 1.000 |
| P6.70 | Load type                                  | 0: constant torque;<br>1: fan water pump;<br>2: promotion;<br>3: reserved |          | 0     |

# H1 series vector control inverter manual V1.0

|                           |             |  |   |    |     |
|---------------------------|-------------|--|---|----|-----|
|                           | P6.80       | Motor cable compensation strength      | 0: low;<br>1: medium;<br>2: high        |    | 0   |
| 07<br>: Control algorithm | P7.50       | Slip compensation                      | -500~500                                | %  | 100 |
|                           | P7.51       | Slip compensation filter constant      | 1~10000                                 | %  | 100 |
|                           | P7.52       | Resonance suppression coefficient      | 0~10000                                 | %  | 100 |
|                           | P7.53       | Low-speed suppression filter constant  | 1~10000                                 | %  | 100 |
|                           | P7.54       | High-speed suppression filter constant | 1~10000                                 | %  | 100 |
|                           | P7.55       | Automatic torque boost coefficient     | 0~300                                   | %  | 100 |
|                           | P7.57       | Low speed minimum current              | 0~300                                   | %  | 50  |
|                           | P7.58       | Static friction lift coefficient       | 0~10000                                 | %  | 100 |
|                           | P7.59       | Static friction lift time              | 0.0~1000.0                              | S  | 0.0 |
|                           | P7.71       | VF curve-F1                            | 0~3000                                  | Hz | 50  |
|                           | P7.72       | VF curve-F2                            |   |    | 50  |
|                           | P7.73       | VF curve-F3                            |   |    | 50  |
|                           | P7.74       | VF curve-F4                            |   |    | 50  |
|                           | P7.75       | VF curve-V0                            | 0~10000                                 | V  | 0   |
|                           | P7.76       | VF curve-V1                            |   |    | *   |
| P7.77                     | VF curve-V2 | *                                      |   |    |     |
| P7.78                     | VF curve-V3 | *                                      |   |    |     |
| P7.79                     | VF curve-V4 | *                                      |   |    |     |
|                           |             |  |   |    |     |
| 09<br>: System protect    | P9.00       | Input phase loss action                | 0: failure;<br>1: alarm;<br>2: invalid; |    | 2   |
|                           | P9.04       | Output phase loss detection            | 0: invalid;<br>1: valid                 |    | 1   |
|                           | P9.06       | ETR selection                          | 0: invalid;<br>1: alarm;<br>2: fault    |    | 2   |
| 10                        | P10.05      | Software version number                |   |    |     |
|                           | P10.10      | Control word                           | 0~4294967295                            |    |     |
|                           | P10.11      | Set value                              | -65535.0~65535.0                        |    |     |
|                           | P10.15      | Current status                         | 0~4294967295                            |    |     |

# H1 series vector control inverter manual V1.0

|                 |        |                                 |                      |      |
|-----------------|--------|---------------------------------|----------------------|------|
| : System status | P10.16 | Fault word 1 status             | 0~4294967295         |      |
|                 | P10.17 | Fault word 2 status             | 0~4294967295         |      |
|                 | P10.18 | Alarm word status               | 0~4294967295         |      |
|                 | P10.20 | Output frequency absolute value | 0.0~65535.0          | Hz   |
|                 | P10.21 | Output frequency                | -65535.0~65535.0     | Hz   |
|                 | P10.22 | Output current                  | 0.00~65535.00        | A    |
|                 | P10.23 | Output voltage                  | 0.0~65535.0          | V    |
|                 | P10.24 | Output torque                   | 0.000~65535.000      | NM   |
|                 | P10.25 | DC voltage                      | 0.0~65535.0          | V    |
|                 | P10.26 | Inverter temperature            | 0~65535              | °C   |
|                 | P10.27 | Inverter hot load               | 0~65535              | %    |
|                 | P10.28 | Motor hot load                  | 0~65535              | %    |
|                 | P10.30 | power                           | 0.000~65535.000      | kW   |
|                 | P10.31 | Energy consumption              | 0.000~4294967.295    | kW*h |
|                 | P10.40 | Hours of power on               | 0.000~4294967.295    | h    |
|                 | P10.41 | Number of power-on              | 0~4294967295         |      |
|                 | P10.60 | Current alarm number            | 0~4294967295         |      |
|                 | P10.61 | Current fault number            | 0~4294967295         |      |
|                 | P10.62 | Last fault number               | 0~4294967295         |      |
|                 | P10.63 | The first two fault numbers     | 0~4294967295         |      |
|                 | P10.70 | S input terminal status         | 0~4294967295         |      |
|                 | P10.71 | A1 terminal input value         | -65535.000~65535.000 | %    |
|                 | P10.72 | A2 terminal input value         | -65535.000~65535.000 | %    |
|                 | P10.74 | Y terminal output status        | 0~4294967295         |      |
|                 | P10.75 | AO1 terminal output value       | -65535.000~65535.000 | %    |
|                 | P10.76 | AO2 terminal output value       | -65535.000~65535.000 | %    |
|                 | P10.78 | Pulse input frequency           | 0.000~10000.000      | kHz  |
|                 | P10.79 | Pulse output frequency          | 0.000~10000.000      | kHz  |

# H1 series vector control inverter manual V1.0

|                          |                               |   |                        |      |       |
|--------------------------|-------------------------------|---|------------------------|------|-------|
|                          | P10.80                        | Encoder count                                   | 0~4294967295           |      |       |
|                          | P10.81                        | Encoder speed                                   | -9999.000~9999.000     | Hz   |       |
|                          | P10.82                        | Encoder angle                                   | 0.0~359.9              | Deg  |       |
|                          | P10.90                        | Set value 1                                     | -999999.000~999999.000 | %    |       |
|                          | P10.91                        | Set value 2                                     | -999999.000~999999.000 | %    |       |
|                          | P10.92                        | Set value 3                                     | -999999.000~999999.000 | %    |       |
|                          | P10.98                        | Display value 1                                 | -99999.000~99999.000   |      |       |
|                          | P10.99                        | Display value 2                                 | -99999.000~99999.000   |      |       |
| 11<br>:<br>Fault<br>list | P11.10                        | Present fault output frequency                  | -999999.0~999999.0     | Hz   | 0.0   |
|                          | P11.11                        | Present fault output current                    | -999999.00~999999.00   | A    | 0.00  |
|                          | P11.12                        | Present fault bus voltage                       | -999999.0~999999.0     | V    | 0.0   |
|                          | P11.13                        | Present faulty inverter temperature             | -999999~999999         | ℃    | 0     |
|                          | P11.14                        | Present fault X terminal status                 | -999999~999999         |      | 0     |
|                          | P11.15                        | Present fault Y terminal status                 | -999999~999999         |      | 0     |
|                          | P11.16                        | Accumulated power-on time                       | 0.000~4294967.295      | h    | 0.000 |
|                          | P11.20                        | Output frequency of previous fault              | -999999.0~999999.0     | Hz   | 0.0   |
|                          | P11.21                        | output current of Previous fault                | -999999.00~999999.00   | A    | 0.00  |
|                          | P11.22                        | Bus voltage of previous fault                   | -999999.0~999999.0     | V    | 0.0   |
|                          | P11.23                        | Inverter temperature of previous fault          | -999999~999999         | ℃    | 0     |
|                          | P11.24                        | S-terminal status of previous fault             | -999999~999999         |      | 0     |
|                          | P11.25                        | Y terminal status of previous fault             | -999999~999999         |      | 0     |
|                          | P11.26                        | Accumulated power-on time of the previous fault | 0.000~4294967.295      | h    | 0.000 |
|                          | P11.30                        | Output frequency of the 2rd faults              | -999999.0~999999.0     | Hz   | 0.0   |
| P11.31                   | The 2rd fault output currents | -999999.00~999999.00                            | A                      | 0.00 |       |

# H1 series vector control inverter manual V1.0

|   |                       |   |                        |   |       |
|---|-----------------------|---|------------------------|---|-------|
|   | P11.32                | Bus voltage of 2rd faults                     | -999999.0~999999.0     | V | 0.0   |
|   | P11.33                | Inverter temperature of the 2rd faults        | -999999~999999         | ℃ | 0     |
|   | P11.34                | S-terminal status of the 2rd faults           | -999999~999999         |   | 0     |
|   | P11.35                | The 2rd fault Y terminal status               | -999999~999999         |   | 0     |
|   | P11.36                | Accumulated power-on time of the 2rd fault    | 0.000~4294967.295      | h | 0.000 |
| 12<br>:<br>Fre<br>e<br>pa<br>ra<br>me<br>te<br>rs | P12.00<br>~<br>P12.19 | Free parameter 1<br>~<br>Free parameters 20   | -999999.000~999999.000 |   | 0.000 |
|   | P12.90<br>~<br>P12.99 | Free parameter 91<br>~<br>Free parameters 100 | -999999.000~999999.000 |   | 0.000 |
|   | P13.00                | Comparator output                             | 0~4294967295           |   | 0     |
| 13<br>:<br>Fun<br>ctio<br>n<br>ou<br>t<br>put     | P13.01                | Logic output                                  | 0~4294967295           |   | 0     |
|   | P13.02                | Linear transformation 1 result                | -999999.000~999999.000 |   | 0.000 |
|   | P13.03                | Linear transformation 2 result                | -999999.000~999999.000 |   | 0.000 |
|   | P13.10                | Single arithmetic operation output 1          | -999999.000~999999.000 |   | 0.000 |
|   | P13.11                | Single arithmetic operation output 2          | -999999.000~999999.000 |   | 0.000 |
|   | P13.12                | Single arithmetic operation output 3          | -999999.000~999999.000 |   | 0.000 |
|   | P13.13                | Single arithmetic operation output 4          | -999999.000~999999.000 |   | 0.000 |
|   | P13.14                | Single arithmetic operation output 5          | -999999.000~999999.000 |   | 0.000 |

# H1 series vector control inverter manual V1.0

|              |        |                               |                        |                            |       |
|--------------|--------|-------------------------------|------------------------|----------------------------|-------|
|              | P13.15 | Math operation 1 output       | -999999.000~999999.000 |                            | 0.000 |
|              | P13.16 | Math operation 2 output       | -999999.000~999999.000 |                            | 0.000 |
|              | P13.17 | Math operation 3 output       | -999999.000~999999.000 |                            | 0.000 |
|              | P13.18 | Math operation 4 output       | -999999.000~999999.000 |                            | 0.000 |
|              | P13.40 | Comparator output 1           | 0~1                    |                            | 0     |
|              | P13.41 | Comparator output 2           | 0~1                    |                            | 0     |
|              | P13.42 | Comparator output 3           | 0~1                    |                            | 0     |
|              | P13.43 | Comparator output 4           | 0~1                    |                            | 0     |
|              | P13.44 | Comparator output 5           | 0~1                    |                            | 0     |
|              | P13.45 | Comparator output 6           | 0~1                    |                            | 0     |
|              | P13.46 | Comparator output 7           | 0~1                    |                            | 0     |
|              | P13.47 | Comparator output 8           | 0~1                    |                            | 0     |
|              | P13.48 | Comparator output 9           | 0~1                    |                            | 0     |
|              | P13.50 | Logic 1 output                | 0~1                    |                            | 0     |
|              | P13.51 | Logic 2 output                | 0~1                    |                            | 0     |
|              | P13.52 | Logic 3 output                | 0~1                    |                            | 0     |
|              | P13.53 | Logic 4 output                | 0~1                    |                            | 0     |
|              | P13.54 | Logic 5 output                | 0~1                    |                            | 0     |
|              | P13.60 | currently counting of Timer 1 | 0~4294967295           |                            | 0     |
|              | P13.61 | Timer 1 current value         | 0~65535                |                            | 0     |
|              | P13.62 | Timer 1 current stage         | 0~16                   |                            | 0     |
|              | P13.63 | Timer 2 is currently counting | 0~4294967295           |                            | 0     |
|              | P13.64 | Timer 2 current value         | 0~65535                |                            | 0     |
|              | P13.65 | Timer 2 current stage         | 0~16                   |                            | 0     |
| 14 : Encoder | P14.01 | Encoder resolution            | 1                      | 1~2 <sup>31</sup>          | 1024  |
|              | P14.02 | Encoder direction             | 1                      | 0: forward;<br>1: reversed | 0     |

# H1 series vector control inverter manual V1.0

|                                |  |  |         |   |   |       |
|--------------------------------|--|--|---------|---|---|-------|
| 16<br>:<br>Logi<br>cal<br>unit | P16.00                                     | Comparator<br>input parameter<br>selection         | 1       | 0~65535   |   | 0     |
|                                | P16.01                                     | Comparator<br>comparison<br>parameter<br>selection | 1       | 0~65535   |   | 0     |
|                                | P16.02                                     | Comparator<br>configuration                        | 1       | 0:>;<br>1:<;<br>2:≥;<br>3:≤;<br>4:=;<br>5:≈;<br>6:≠ |   | 0     |
|                                | P16.03                                     | Comparator<br>delay time                           | 2       | 0.000~600.000                                       | s | 0.000 |
|                                | P16.04                                     | Comparator<br>input parameter<br>selection         | 2       | 0~65535   |   | 0     |
|                                | P16.05                                     | Comparator<br>comparison<br>parameter<br>selection | 2       | 0~65535   |   | 0     |
|                                | P16.06                                     | Comparator<br>configuration                        | 2       | 0:>;<br>1:<;<br>2:≥;<br>3:≤;<br>4:=;<br>5:≈;<br>6:≠ |   | 0     |
|                                | P16.07                                     | Comparator<br>delay time                           | 2       | 0.000~600.000                                       | s | 0.000 |
|                                | P16.08                                     | Comparator<br>input parameter<br>selection         | 3       | 0~65535   |   | 0     |
|                                | P16.09                                     | Comparator<br>comparison<br>parameter<br>selection | 3       | 0~65535   |   | 0     |
|                                | P16.10                                     | Comparator<br>configuration                        | 3       | 0:>;<br>1:<;<br>2:≥;<br>3:≤;<br>4:=;<br>5:≈;<br>6:≠ |   | 0     |
|                                | P16.11                                     | Comparator<br>delay time                           | 3       | 0.000~600.000                                       | s | 0.000 |
| P16.12                         | Comparator<br>input parameter<br>selection | 4  | 0~65535 |   | 0 |       |

|        |   |   |   |   |       |
|--------|---|---|---|---|-------|
| P16.13 | Comparator comparison parameter selection | 4 | 0~65535   |   | 0     |
| P16.14 | Comparator configuration                  | 4 | 0:>;<br>1:<;<br>2:≥;<br>3:≤;<br>4:=;<br>5:≠;<br>6:≠ |   | 0     |
| P16.15 | Comparator delay time                     | 4 | 0.000~600.000                                       | s | 0.000 |
| P16.16 | Comparator input parameter selection      | 5 | 0~65535   |   | 0     |
| P16.17 | Comparator comparison parameter selection | 5 | 0~65535   |   | 0     |
| P16.18 | Comparator configuration                  | 5 | 0:>;<br>1:<;<br>2:≥;<br>3:≤;<br>4:=;<br>5:≠;<br>6:≠ |   | 0     |
| P16.19 | Comparator delay time                     | 5 | 0.000~600.000                                       | s | 0.000 |
| P16.20 | Comparator input parameter selection      | 6 | 0~65535   |   | 0     |
| P16.21 | Comparator comparison parameter selection | 6 | 0~65535   |   | 0     |
| P16.22 | Comparator configuration                  | 6 | 0:>;<br>1:<;<br>2:≥;<br>3:≤;<br>4:=;<br>5:≠;<br>6:≠ |   | 0     |
| P16.23 | Comparator delay time                     | 6 | 0.000~600.000                                       | s | 0.000 |
| P16.24 | Comparator input parameter selection      | 7 | 0~65535   |   | 0     |
| P16.25 | Comparator comparison parameter selection | 7 | 0~65535   |   | 0     |

|        |   |       |   |   |       |
|--------|---|-------|---|---|-------|
| P16.26 | Comparator configuration                  | 7     | 0:>;<br>1:<;<br>2:≥;<br>3:≤;<br>4:=;<br>5:≠;<br>6:≠ |   | 0     |
| P16.27 | Comparator delay time                     | 7     | 0.000~600.000                                       | s | 0.000 |
| P16.28 | Comparator input parameter selection      | 8     | 0~65535   |   | 0     |
| P16.29 | Comparator comparison parameter selection | 8     | 0~65535   |   | 0     |
| P16.30 | Comparator configuration                  | 8     | 0:>;<br>1:<;<br>2:≥;<br>3:≤;<br>4:=;<br>5:≠;<br>6:≠ |   | 0     |
| P16.31 | Comparator delay time                     | 8     | 0.000~600.000                                       | s | 0.000 |
| P16.32 | Comparator input parameter selection      | 9     | 0~65535   |   | 0     |
| P16.33 | Comparator comparison parameter selection | 9     | 0~65535   |   | 0     |
| P16.34 | Comparator configuration                  | 9     | 0:>;<br>1:<;<br>2:≥;<br>3:≤;<br>4:=;<br>5:≠;<br>6:≠ |   | 0     |
| P16.35 | Comparator delay time                     | 9     | 0.000~600.000                                       | s | 0.000 |
| P16.36 | Logic unit parameter selection 1          | 1     | 0~65535   |   | 0     |
| P16.37 | Logic unit input selection 1              | 1 bit | 0~32  |   | 0     |
| P16.38 | Logic unit parameter selection 2          | 1     | 0~65535   |   | 0     |
| P16.39 | Logic unit input selection 2              | 1 bit | 0~32  |   | 0     |

# H1 series vector control inverter manual V1.0

|        |                                  |       |  |  |   |
|--------|----------------------------------|-------|--|--|---|
| P16.40 | Logic unit parameter selection 3 | 1     | 0~65535  |  | 0 |
| P16.41 | Logic unit input selection 3     | 1 bit | 0~32   |  | 0 |
| P16.42 | Logical unit configuration 1     | 1     | 0: No effect;<br>1: with;<br>2: OR;<br>3: NAND;<br>4: NOR;<br>5: XOR |  | 0 |
| P16.43 | Logical unit configuration 2     | 1     | 0: No effect;<br>1: with;<br>2: OR;<br>3: NAND;<br>4: NOR;<br>5: XOR |  | 0 |
| P16.44 | Logic unit parameter selection 1 | 2     | 0~65535  |  | 0 |
| P16.45 | Logic unit input selection 1     | 2 bit | 0~32   |  | 0 |
| P16.46 | Logic unit parameter selection 2 | 2     | 0~65535  |  | 0 |
| P16.47 | Logic unit input selection 2     | 2 bit | 0~32   |  | 0 |
| P16.48 | Logic unit parameter selection 3 | 2     | 0~65535  |  | 0 |
| P16.49 | Logic unit input selection 3     | 2 bit | 0~32   |  | 0 |
| P16.50 | Logical unit configuration 1     | 2     | 0: No effect;<br>1: with;<br>2: OR;<br>3: NAND;<br>4: NOR;<br>5: XOR |  | 0 |
| P16.51 | Logical unit configuration 2     | 2     | 0: No effect;<br>1: with;<br>2: OR;<br>3: NAND;<br>4: NOR;<br>5: XOR |  | 0 |
| P16.76 | Selector parameter source        | 1     | 0~65535  |  | 0 |
| P16.77 | Selector setting                 | 1     | 0~16   |  | 0 |

## H1 series vector control inverter manual V1.0

|        |                                 |   |         |  |   |
|--------|---------------------------------|---|---------|--|---|
| P16.78 | Selector destination parameters | 1 | 0~65535 |  | 0 |
| P16.79 | Selector parameter source       | 2 | 0~65535 |  | 0 |
| P16.80 | Selector setting                | 2 | 0~16    |  | 0 |
| P16.81 | Selector destination parameters | 2 | 0~65535 |  | 0 |
| P16.82 | Selector parameter source       | 3 | 0~65535 |  | 0 |
| P16.83 | Selector setting                | 3 | 0~16    |  | 0 |
| P16.84 | Selector destination parameters | 3 | 0~65535 |  | 0 |
| P16.85 | Selector parameter source       | 4 | 0~65535 |  | 0 |
| P16.86 | Selector setting                | 4 | 0~16    |  | 0 |
| P16.87 | Selector destination parameters | 4 | 0~65535 |  | 0 |
| P16.88 | Selector parameter source       | 5 | 0~65535 |  | 0 |
| P16.89 | Selector setting                | 5 | 0~16    |  | 0 |
| P16.90 | Selector destination parameters | 5 | 0~65535 |  | 0 |
| P16.91 | Selector parameter source       | 6 | 0~65535 |  | 0 |
| P16.92 | Selector setting                | 6 | 0~16    |  | 0 |
| P16.93 | Selector destination parameters | 6 | 0~65535 |  | 0 |
| P16.94 | Selector parameter source       | 7 | 0~65535 |  | 0 |
| P16.95 | Selector setting                | 7 | 0~16    |  | 0 |
| P16.96 | Selector destination parameters | 7 | 0~65535 |  | 0 |

# H1 series vector control inverter manual V1.0

|                                       |        |  |   |  |  |          |
|---------------------------------------|--------|--|---|--|--|----------|
|                                       | P16.97 | Selector parameter source                    | 8 | 0~65535  |  | 0        |
|                                       | P16.98 | Selector setting                             | 8 | 0~16   |  | 0        |
|                                       | P16.99 | Selector destination parameters              | 8 | 0~65535  |  | 0        |
| 17 :<br>Mat<br>h<br>ope<br>ratio<br>n | P17.00 | Linear transformation parameter source       | 1 | 0~65535  |  | 0        |
|                                       | P17.01 | Linear transformation X1                     | 1 | -999999.000~999999.000   |  | 0.000    |
|                                       | P17.02 | Linear transformation X2                     | 1 | -999999.000~999999.000   |  | 50.000   |
|                                       | P17.03 | Linear transformation Y1                     | 1 | -999999.000~999999.000   |  | 0.000    |
|                                       | P17.04 | Linear transformation Y2                     | 1 | -999999.000~999999.000   |  | 1500.000 |
|                                       | P17.05 | Linear transformation parameter source       | 2 | 0~65535  |  | 0        |
|                                       | P17.06 | Linear transformation X1                     | 2 | -999999.000~999999.000   |  | 0.000    |
|                                       | P17.07 | Linear transformation X2                     | 2 | -999999.000~999999.000   |  | 0.000    |
|                                       | P17.08 | Linear transformation Y1                     | 2 | -999999.000~999999.000   |  | 0.000    |
|                                       | P17.09 | Linear transformation Y2                     | 2 | -999999.000~999999.000   |  | 0.000    |
|                                       | P17.16 | Single arithmetic operation parameter source | 1 | 0~65535  |  | 0        |
|                                       | P17.17 | Single arithmetic operation setting          | 1 | 0:ABS;<br>1:Sqrt;<br>2:Sin;<br>3:Cos;<br>4:power2;<br>5:Power3<br>6: random number |  | 0        |

# H1 series vector control inverter manual V1.0

|        |   |   |  |  |   |
|--------|---|---|--|--|---|
| P17.18 | Single arithmetic operation parameter source  | 2 | 0~65535  |  | 0 |
| P17.19 | Single arithmetic operation operation setting | 2 | 0:ABS;<br>1:Sqrt;<br>2:Sin;<br>3:Cos;<br>4:power2;<br>5:Power3<br>6: random number |  | 0 |
| P17.20 | Single arithmetic operation parameter source  | 3 | 0~65535  |  | 0 |
| P17.21 | Single arithmetic operation operation setting | 3 | 0:ABS;<br>1:Sqrt;<br>2:Sin;<br>3:Cos;<br>4:power2;<br>5:Power3<br>6: random number |  | 0 |
| P17.22 | Single arithmetic operation parameter source  | 4 | 0~65535  |  | 0 |
| P17.23 | Single arithmetic operation operation setting | 4 | 0:ABS;<br>1:Sqrt;<br>2:Sin;<br>3:Cos;<br>4:power2;<br>5:Power3<br>6: random number |  | 0 |
| P17.24 | Single arithmetic operation parameter source  | 5 | 0~65535  |  | 0 |
| P17.25 | Single arithmetic operation operation setting | 5 | 0:ABS;<br>1:Sqrt;<br>2:Sin;<br>3:Cos;<br>4:power2;<br>5:Power3<br>6: random number |  | 0 |
| P17.26 | Mathematical operation Parameter source 1     | 1 | 0~65535  |  | 0 |

# H1 series vector control inverter manual V1.0

|        |   |   |  |  |   |
|--------|---|---|--|--|---|
| P17.27 | Mathematical operation Parameter source 2 | 1 | 0~65535  |  | 0 |
| P17.28 | Mathematical operation Parameter source 3 | 1 | 0~65535  |  | 0 |
| P17.29 | Math operation 1 Operation setting 1      |   | 0:No effect;<br>1:+;<br>2:-;<br>3:*;<br>4:/;<br>5:MAX;<br>6:Min;<br>7:Mean |  | 0 |
| P17.30 | Math operation 1 Operation setting 2      |   | 0:No effect;<br>1:+;<br>2:-;<br>3:*;<br>4:/;<br>5:MAX;<br>6:Min;<br>7:Mean |  | 0 |
| P17.31 | Mathematical operation Parameter source 1 | 2 | 0~65535  |  | 0 |
| P17.32 | Mathematical operation Parameter source 2 | 2 | 0~65535  |  | 0 |
| P17.33 | Mathematical operation Parameter source 3 | 2 | 0~65535  |  | 0 |
| P17.34 | Math operation 2 Operation setting 1      |   | 0:No effect<br>1:+;<br>2:-;<br>3:*;<br>4:/;<br>5:MAX;<br>6:Min;<br>7:Mean  |  | 0 |
| P17.35 | Math operation 2 Operation setting 2      |   | 0:No effect;<br>1:+;<br>2:-;<br>3:*;<br>4:/;<br>5:MAX;<br>6:Min;<br>7:Mean |  | 0 |

# H1 series vector control inverter manual V1.0

|        |   |   |  |  |   |
|--------|---|---|--|--|---|
| P17.36 | Mathematical operation Parameter source 1 | 3 | 0~65535  |  | 0 |
| P17.37 | Mathematical operation Parameter source 2 | 3 | 0~65535  |  | 0 |
| P17.38 | Mathematical operation Parameter source 3 | 3 | 0~65535  |  | 0 |
| P17.39 | Math operation 3 Operation setting 1      |   | 0:No effect;<br>1:+;<br>2:-;<br>3:*;<br>4:/;<br>5:MAX;<br>6:Min;<br>7:Mean |  | 0 |
| P17.40 | Math operation 3 Operation setting 2      |   | 0:No effect;<br>1:+;<br>2:-;<br>3:*;<br>4:/;<br>5:MAX;<br>6:Min;<br>7:Mean |  | 0 |
| P17.41 | Mathematical operation Parameter source 1 | 4 | 0~65535  |  | 0 |
| P17.42 | Mathematical operation Parameter source 2 | 4 | 0~65535  |  | 0 |
| P17.43 | Mathematical operation Parameter source 3 | 4 | 0~65535  |  | 0 |
| P17.44 | Math operation 4 Operation setting 1      |   | 0:No effect;<br>1:+;<br>2:-;<br>3:*;<br>4:/;<br>5:MAX;<br>6:Min;<br>7:Mean |  | 0 |

|                                     |                          |  |  |   |    |
|-------------------------------------|--------------------------|--|--|---|----|
|                                     | P17.45                   | Math operation<br>4 Operation<br>setting 2 | 0:No effect;<br>1:+;<br>2:-;<br>3*;<br>4/;<br>5:MAX;<br>6:Min;<br>7:Mean             |   | 0  |
| 18<br>:<br>Tim<br>er<br>cont<br>rol | P18.00                   | Timer 1 clock<br>source                    | 0:1mS;<br>1:10mS;<br>2:100mS;<br>3:1S;<br>200~3799:Address                           |   | 0  |
|                                     | P18.01                   | Timer 1 working<br>mode                    | 0: stop at the end of a single<br>run;<br>1 ~ 16: Set the start of the<br>next cycle |   | 0  |
|                                     | P18.02                   | Timer 1 control<br>commands                | Bit0: enable;<br>Bit1: Start counting;<br>Bit2: pause counting;<br>Bit3: Clear count |   | 0  |
|                                     | P18.03                   | Timer 1 set<br>value                       | -1~4294967295  |   | -1 |
|                                     | P18.04                   | Timer 1 phase 1<br>time                    | 0~4294967295   |   | 0  |
|                                     | P18.05                   | Timer 1 phase 2<br>time                    | 0~4294967295   |   | 0  |
|                                     | P18.06                   | Timer 1 phase 3<br>time                    | 0~4294967295   |   | 0  |
|                                     | P18.07                   | Timer 1 phase 4<br>time                    | 0~4294967295   |   | 0  |
|                                     | P18.08                   | Timer 1 phase 5<br>time                    | 0~4294967295   |   | 0  |
|                                     | P18.09                   | Timer 1 phase 6<br>time                    | 0~4294967295   |   | 0  |
|                                     | P18.10                   | Timer 1 phase 7<br>time                    | 0~4294967295   |   | 0  |
|                                     | P18.11                   | Timer 1 phase 8<br>time                    | 0~4294967295   |   | 0  |
|                                     | P18.12                   | Timer 1 phase 9<br>time                    | 0~4294967295   |   | 0  |
|                                     | P18.13                   | Timer 1 phase<br>10 time                   | 0~4294967295   |   | 0  |
|                                     | P18.14                   | Timer 1 phase<br>11 time                   | 0~4294967295   |   | 0  |
| P18.15                              | Timer 1 phase<br>12 time | 0~4294967295                               |  | 0 |    |
| P18.16                              | Timer 1 phase<br>13 time | 0~4294967295                               |  | 0 |    |
| P18.17                              | Timer 1 phase<br>14 time | 0~4294967295                               |  | 0 |    |

|        |                          |  |  |    |
|--------|--------------------------|--|--|----|
| P18.18 | Timer 1 phase 15 time    | 0~4294967295   |  | 0  |
| P18.19 | Timer 1 phase 16 time    | 0~4294967295   |  | 0  |
| P18.20 | Timer 1 clock source     | 0:1mS;<br>1:10mS;<br>2:100mS;<br>3:1S;<br>200~3799:Address                           |  | 0  |
| P18.21 | Timer 1 working mode     | 0: stop at the end of a single run;<br>1 ~ 16: Set the start of the next cycle       |  | 0  |
| P18.22 | Timer 1 control commands | Bit0: enable;<br>Bit1: Start counting;<br>Bit2: pause counting;<br>Bit3: Clear count |  | 0  |
| P18.23 | Timer 1 set value        | -1~4294967295  |  | -1 |
| P18.24 | Timer 1 phase 1 time     | 0~4294967295   |  | 0  |
| P18.25 | Timer 1 phase 2 time     | 0~4294967295   |  | 0  |
| P18.26 | Timer 1 phase 3 time     | 0~4294967295   |  | 0  |
| P18.27 | Timer 1 phase 4 time     | 0~4294967295   |  | 0  |
| P18.28 | Timer 1 phase 5 time     | 0~4294967295   |  | 0  |
| P18.29 | Timer 1 phase 6 time     | 0~4294967295   |  | 0  |
| P18.30 | Timer 1 phase 7 time     | 0~4294967295   |  | 0  |
| P18.31 | Timer 1 phase 8 time     | 0~4294967295   |  | 0  |
| P18.32 | Timer 1 phase 9 time     | 0~4294967295   |  | 0  |
| P18.33 | Timer 1 phase 10 time    | 0~4294967295   |  | 0  |
| P18.34 | Timer 1 phase 11 time    | 0~4294967295   |  | 0  |
| P18.35 | Timer 1 phase 12 time    | 0~4294967295   |  | 0  |
| P18.36 | Timer 1 phase 13 time    | 0~4294967295   |  | 0  |
| P18.37 | Timer 1 phase 14 time    | 0~4294967295   |  | 0  |
| P18.38 | Timer 1 phase 15 time    | 0~4294967295   |  | 0  |
| P18.39 | Timer 1 phase 16 time    | 0~4294967295   |  | 0  |

## 01 parameters: system configuration

| Parameter NO. | Parameter Name        | Setting range   | Unit | Factory value |
|---------------|-----------------------|---|------|---------------|
| P1.11         | Parameter operation   | 0: normal operation;<br>1: Parameter initialization, initialize all parameters except P1.XX and application macro;<br>2: Initialize all parameters; |      | 0             |
| P1.13         | Set keyword           | 0~9999  |      | 0             |
| P1.14         | Set keyword confirmed | 0~9999  |      | 0             |
| P1.15         | Input keyword         | 0~9999  |      | 0             |

- Function:Parameter operation setting

➤ **Principle explanation:**

Set P1.13 and P1.14 to the same non-zero number, and the set password is valid.

| Parameter NO. | Parameter Name | Setting range | Unit | Factory value |
|---------------|----------------|---------------|------|---------------|
| P1.20         | Apply macro    | 0~9999        |      | 0             |
| P1.21         | Formula        | 0~10000       |      | 0             |

- Function:** choose application macro, formula

**Principle explanation:**

Application macro is a group of parameter. Activating the corresponding application macro is same to setting the macro parameter set.

Set P1.20 to select the corresponding macro, you can select 2 macros at the same time. Each two-digit number represents a macro, thousand bit and hundred bit form a macro, and ten bit and unit form another macro. When the corresponding macro setting value of P1.20 changes, the corresponding macro configuration action is applied, and any parameters can be manually modified after the configuration is completed. For specific macro information, please refer to the application macro detailed description.

A formula is a set of parameter sets, and the corresponding formula configuration action is executed every time the power is turned on and switched.

| Parameter NO. | Parameter Name          | Setting range                            | Unit | Factory value |
|---------------|-------------------------|--|------|---------------|
| P1.30         | virtual terminal to set | 0~199:Value setting;<br>200~9999:Address |      | 0             |

- Function:**virtual terminal to set

**Principle explanation:**

The virtual terminal is used as a function extension. When set to 0 ~ 199, this value is the set value; when set to 200 ~ 9999, this setting is the address. The address is the selected parameter number, and the actual value is determined by the current value of the selected parameter number. For usage details, please refer to P3.00 ~ P3.09.

| Parameter NO. | Parameter Name | Setting range  | Unit | Factory value |
|---------------|----------------|--|------|---------------|
| P1.39         | Command Mode   | 0:Single Command source mode;<br>1:Multi-command source mode |      | 0             |

- Function:Select command mode

Principle explanation:

The command mode determines the command source . The single-command source mode specifies one source with an index number, and the multi-command source mode can specify multiple sources in binary. For usage details, please refer to P3.00 ~ P3.09.

| Parameter NO. | Parameter Name         | Setting range                                | Unit | Factory value |
|---------------|------------------------|--|------|---------------|
| P1.40         | Communication Protocol | 0:Reserved;<br>1:MODBUS RTU;<br>2~6:Reserved |      | 1             |

- Function:Select communication protocol (only supports MOUDBUS RTU)

| Parameter NO. | Parameter Name | Setting range | Unit | Factory value |
|---------------|----------------|---------------|------|---------------|
| P1.41         | Address        | 0~247         |      | 1             |

- Function:Set the local address of the inverter

| Parameter NO. | Parameter Name | Setting range  | Unit | Factory value |
|---------------|----------------|--|------|---------------|
| P1.42         | Baud Rate      | 0:2400;<br>1:4800;<br>2:9600;<br>3:19200;<br>4:38400;<br>5~10:Reserved | Bps  | 3             |
| P1.43         | Parity Check   | 0:No Check;<br>1:Even check;<br>2:Odd check                            |      | 0             |
| P1.44         | Data Bit       | 8~9  | Bits | 8             |
| P1.45         | Stop Bit       | 0.0~2.0  | Bit  | 1.0           |

- Function:Communication port configuration

| Parameter NO. | Parameter Name         | Setting range   | Unit | Factory value |
|---------------|------------------------|---|------|---------------|
| P1.47         | parameter decimal mode | 0 ~ 123<br>Ones place: 0: Decimal place remains unchanged,<br>1: The number of decimal places becomes two,<br>2: The decimal place becomes one,<br>3: Become no decimal places;<br>Tens place: 0: Decimal place remains unchanged,<br>1: The decimal place becomes one,<br>2: Become no decimal places;<br>Hundreds: 0: The decimal place remains unchanged,<br>1: Become no decimal places |      | 0             |

- Function:Adjust parameter decimal places

Principle explanation:

The parameter decimal point mode only affects communication, changes the parameter value during communication.

P1.47's unit place are for the parameters of three decimal places: 0: the decimal place remains unchanged, 1: the decimal place becomes two, 2: the decimal place becomes one, 3: becomes no decimal place.

The ten place of P1.47 are for the parameters of two decimal places: 0: the decimal place remains unchanged, 1: the decimal place becomes one, 2: becomes no decimal place.

P1.47's hundred place are for one decimal place parameter: 0: decimal place remains unchanged, 1: becomes no decimal place.

For example: 2.51 = 30.000s, when 1.47 = 000, serial port read data = 30000; when 1.47 = 001, serial port read data = 3000; when 1.47 = 002, serial port read data = 300; when 1.47 = 003, Serial port reading data = 30.

For example: 6.44 = 43.66, when 1.47 = 000, serial port read data = 4366; when 1.47 = 010, serial port read data = 436; when 1.47 = 020, serial port read data = 43

| Parameter NO. | Parameter Name           | Setting range   | Unit | Factory value |
|---------------|--------------------------|---|------|---------------|
| P1.63         | Keyboard settings source | 0: Keyboard numeric setting (P2.92);<br>1: Keyboard potentiometer setting |      | 1             |

- Function:Set keyboard settings source

Principle explanation:

Select the source of keyboard setting value, digital setting (P2.92) or keyboard

potentiometer.

When the keyboard potentiometer setting is selected, P2.92 will keep the current potentiometer setting data, then select the keyboard numeric setting, and set the frequency to the previous potentiometer setting data.

| Parameter NO. | Parameter Name                        | Setting range   | Unit | Factory value |
|---------------|---------------------------------------|---|------|---------------|
| P1.66         | keyboard M light Source               | 0: always 0;<br>1: always 1;<br>2: stopped;<br>3: running;<br>4: fault;<br>5: Warning;<br>6: Reversing;<br>7: ready;<br>64: STO state;<br>100 ~ 9999: address |      | 5             |
| P1.67         | Keyboard M Lamp source<br>Bit display | 0~31  |      | 0             |

- Function: Select the signal source of the keyboard M light

Principle explanation:

The set value of keyboard M light source is bigger or equal to 100 (address mode), the address is the selected parameter number, the actual value is determined by the current value of the selected parameter number. The bit position of the keyboard M light source is set bit selection. When the terminal source is address 100 ~ 9999, the bit setting is valid. The keyboard M light source setting value is less than 100 (non-address mode), and the keyboard M light source bit does not need to be set. The function description of the terminal source is as follows:

| Setting value | Function  | Description                                     |
|---------------|-----------|---|
| 0             | Always 0  | Keyboard M light off                            |
| 1             | Always 1  | Keyboard M lights up                            |
| 2             | stopped   | The keyboard M light is on in the stopped state |
| 3             | running   | The keyboard M light is on in the running state |
| 4             | Fault     | The keyboard M light is on in the fault state   |
| 5             | Warning   | Keyboard M light is on in warning state         |
| 6             | Reversing | The keyboard M light is on in the reverse state |

|          |            |  |
|----------|------------|--|
| 7        | Ready      | The keyboard M light is on in the ready state              |
| 64       | STO status | The keyboard M light is on in the STO state,               |
| 100~9999 | address    | Select the parameter as the keyboard M light output source |

| Parameter NO. | Parameter Name | Setting range | Unit | Factory value |
|---------------|----------------|---------------|------|---------------|
| P1.68         | value 1 source | 0~9999        |      | 1011(P10.11)  |
| P1.69         | value 2 source | 0~9999        |      | 1091(P10.91)  |

- Function: Set display value source

**Principle explanation:**

Set the source of the display value, the source is the parameter number, and the value of the corresponding parameter number is put into P10.98 and P10.99 to be used as the corresponding monitoring display of the keyboard. See the keyboard description for details. The keyboard display value 1 and display value 2 can be flexibly selected, and the factory value displays the set value and set value 2. If want to select other status data display, set P1.68 and P1.69 to the corresponding parameter number, for example: the keyboard displays acceleration time 0 and acceleration time 1, you need to set the parameters P1.68 = 250, P1.69 = 251, at this time, the data of the keyboard display value 1 is the acceleration time 0, and the data of the display value 2 is the acceleration time 1.

## 02 parameters: setting channels

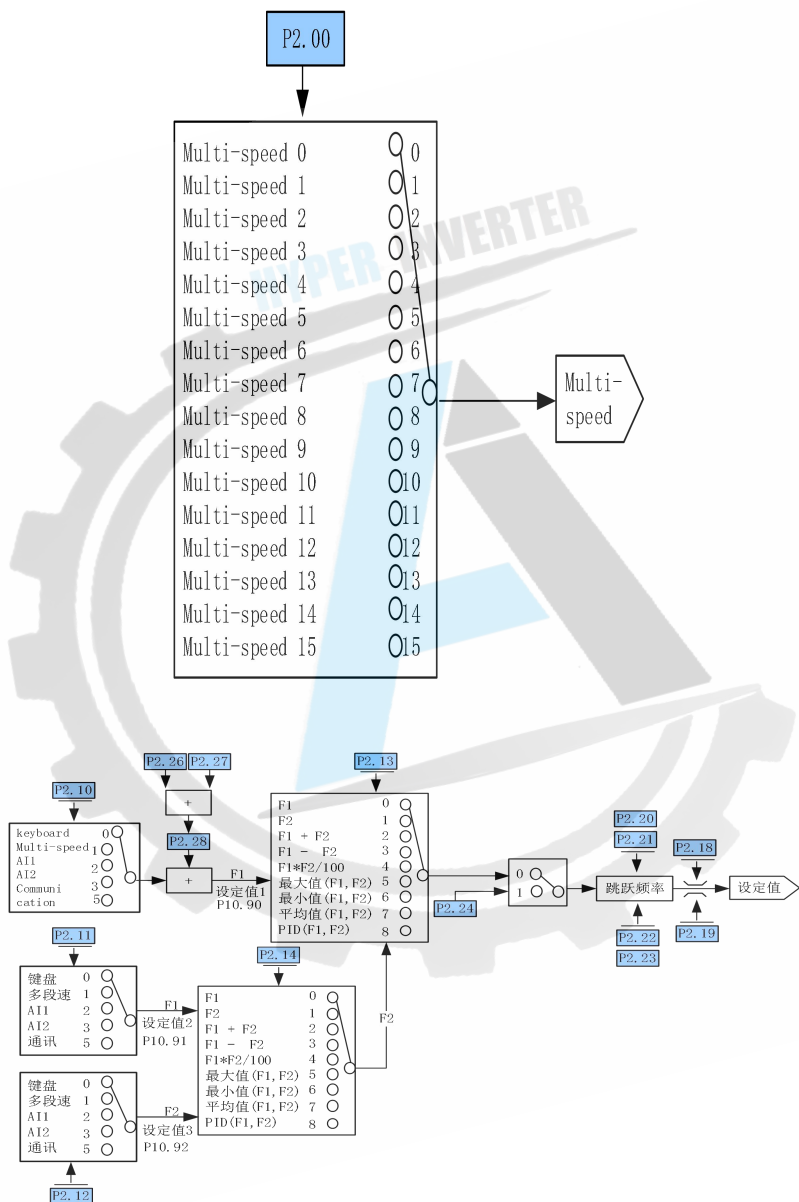

Figure 6-2-1 Set value source and channel setting

| Parameter NO. | Parameter Name                         | Setting range  | Unit | Factory value |
|---------------|--|--|------|---------------|
| P2.00         | Multi-speed source                     | 0~11111111<br>Units: S1;<br>Tens: S2;<br>Hundreds: S3;<br>...                      |      | 0             |
| P2.01         | Source of acceleration time            |  |      | 0             |
| P2.02         | Source of deceleration time            |  |      | 0             |
| P2.03         | Source of incremental instruction (UP) | Units: keyboard;<br>Tens: communication;<br>Hundreds: S1;<br>Thousands: S2;<br>... |      | 0             |
| P2.04         | Source of Decrement instruction (DOWN) |  |      | 0             |

- Function: Select command source

P2.00: Multi-speed source, select the corresponding external terminal, see P2.30 ~ P2.45 for multispeed 0 ~ 15.

P2.01: Source of acceleration time, select the corresponding external terminal. For acceleration time, please refer to P2.50 ~ P2.65.

P2.02: source of deceleration time, select the corresponding external terminal, see P2.70 ~ P2.85 for deceleration time.

P2.03: Source of incremental instruction (UP), select the corresponding source.

P2.04: Decrease instruction (DOWN) source, select the corresponding source.

See P2.26 ~ P2.28 for UP / DOWN parameters.

Example: Select S2, S3, S4 as effective external terminals to control 8-stage speed:

Step 1: Select S2, S3, S4 as multi-speed terminals, P2.00 is set to 1110;

Step 2: Control S2, S3, S4 to switch multi-speed, the corresponding relationship between 8 multi-speed is as follows:

Table 6-2-1

| S4 | S3 | S2 | Effective multi-speed |
|----|----|----|-----------------------|
| 0  | 0  | 0  | Multi-speed 0         |
| 0  | 0  | 1  | Multi-speed 1         |
| 0  | 1  | 0  | Multi-speed 2         |
| 0  | 1  | 1  | Multi-speed 3         |
| 1  | 0  | 0  | Multi-speed 4         |
| 1  | 0  | 1  | Multi-speed 5         |
| 1  | 1  | 0  | Multi-speed 6         |
| 1  | 1  | 1  | Multi-speed 7         |

| Parameter NO. | Parameter Name     | Setting range   | Unit | Factory value |
|---------------|--------------------|---|------|---------------|
| P2.10         | Set value source 1 | 0: keyboard;<br>1: Multi-speed;<br>2: AI1;<br>3: AI2;<br>5: communication;<br>9: pulse input<br>200 ~ 9999: address |      | 0             |
| P2.11         | Set value source 2 |   |      | 0             |
| P2.12         | Set value source 3 |   |      | 0             |

- Function: Select the source of the set value

- See P1.63 for keyboard setting value.
- The communication setting value is written into P2.90 through communication.
- When the setting is 200 ~ 9999, this setting is the address. The address is the selected parameter number, and the actual value is determined by the current value of the selected parameter number.

| Parameter NO. | Parameter Name                       | Setting range  | Unit | Factory value |
|---------------|--------------------------------------|--|------|---------------|
| P2.13         | Set channel 1 relationship selection | 0:F1;<br>1:F2;<br>2:F1+F2;<br>3:F1-F2;<br>4:F1*F2/100;<br>5:Maximum value(F1,F2);<br>6:Minimum value(F1,F2) ;<br>7:Average value(F1,F2) ;<br>8:PID(F1,F2); |      | 0             |
| P2.14         | Set channel 2 relationship selection |  |      | 0             |

- Function: Select to set the channel relationship

Principle explanation:

In the setting channel relationship, set 0 to select the F1 channel set value; Set 1 to select the F2 channel set value; Set 2 to select the sum of the F1 and F2 channel set values; Set 3 to select the difference between the F1 and F2 channel set values ; Set 4 to select the product of F1 and F2 channel set value divided by 100; Set 5 to select the maximum value in F1 and F2; Set 6 to select the minimum value in F1 and F2; Set 7 to select the average value of F1 and F2; Set 8 to select PID Control (F1 is set, F2 is feedback).

| Parameter NO. | Parameter Name  | Setting range        | Unit | Factory value |
|---------------|-----------------|----------------------|------|---------------|
| P2.18         | Maximum setting | -99999.000~99999.000 |      | 50.000        |
| P2.19         | Minimum setting |                      |      | 0.000         |

- Function: limit the set value range

Principle explanation:

Limit the setting range to [P2.19, P2.18]. When each setting source is in units of %, the maximum setting value (P2.18) represents 100%, which is based on the maximum setting value. The output frequency is less than or equal to P5.08 motor frequency upper limit.

| Parameter NO. | Parameter Name                | Setting range      | Unit | Factory value |
|---------------|-------------------------------|--------------------|------|---------------|
| P2.20         | Avoid-frequency 1 start point | -1000.000~1000.000 | %    | 0.000         |
| P2.21         | Avoid-frequency 1 stop point  |                    |      |               |
| P2.22         | Avoid-frequency 2 start point |                    |      |               |
| P2.23         | Avoid-frequency 2 stop point  |                    |      |               |

- Function: Set the avoidance frequency

Principle explanation:

The set frequency of the inverter is given in a skipped manner in the avoidance frequency range in the manner of Figure 6-2-2.

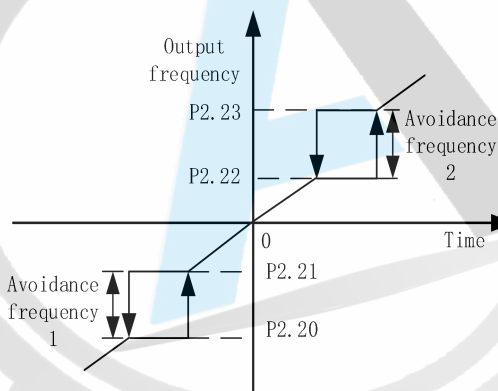

Figure 6-2-2 Frequency of avoidance

| Parameter NO. | Parameter Name | Setting range      | Unit | Factory value |
|---------------|----------------|--------------------|------|---------------|
| P2.24         | Jog frequency  | -1000.000~1000.000 | %    | 10.000        |

- Function: Set the Jog frequency as a percentage of the maximum set value of P2.18. Jog command see P3.03

| Parameter NO. | Parameter Name | Setting range | Unit | Factory value |
|---------------|----------------|---------------|------|---------------|
|---------------|----------------|---------------|------|---------------|

|       |  |   |   |       |
|-------|--|---|---|-------|
| P2.26 | Increase and decrease (UP / DOWN) Step-frequency   | -100.0~100.0  | % | 0.2   |
| P2.27 | Increase and decrease (UP / DOWN) memory selection | 0: no memory;<br>1: Only power down memory;<br>2: Only stop memory;<br>3: Both power down and stop memory |   | 3     |
| P2.28 | Speed up and down frequency                        | -1000.000~1000.000  | % | 0.000 |

- Function: Select UP / DOWN function

Principle explanation:

When the signal is activated, the frequency setting of the inverter increases or decreases by one unit. When the switch is held, the frequency will rapidly increase upward or downward to a certain time, and then increase or decrease uniformly. See P2.03 ~ P2.04 for the selection of UP / DOWN signal. P2.28 is only used for clearing UP / DOWN results. The data has no intuitive meaning after standardization.

| Parameter NO. | Parameter Name | Setting range      | Unit | Factory value |
|---------------|----------------|--------------------|------|---------------|
| P2.30         | Multi-speed 0  | -1000.000~1000.000 | %    | 0.000         |
| P2.31         | Multi-speed 1  |                    |      |               |
| P2.32         | Multi-speed 2  |                    |      |               |
| P2.33         | Multi-speed 3  |                    |      |               |
| P2.34         | Multi-speed 4  |                    |      |               |
| P2.35         | Multi-speed 5  |                    |      |               |
| P2.36         | Multi-speed 6  |                    |      |               |
| P2.37         | Multi-speed 7  |                    |      |               |
| P2.38         | Multi-speed 8  |                    |      |               |
| P2.39         | Multi-speed 9  |                    |      |               |
| P2.40         | Multi-speed 10 |                    |      |               |
| P2.41         | Multi-speed 11 |                    |      |               |
| P2.42         | Multi-speed 12 |                    |      |               |
| P2.43         | Multi-speed 13 |                    |      |               |
| P2.44         | Multi-speed 14 |                    |      |               |
| P2.45         | Multi-speed 15 |                    |      |               |

- Function: Multi-stage speed setting

| Parameter NO. | Parameter Name     | Setting range  | Unit | Factory value |
|---------------|--------------------|----------------|------|---------------|
| P2.50         | Accelerate time 0  | 0.050~3600.000 | S    | *             |
| P2.51         | Accelerate time 1  |                |      |               |
| P2.52         | Accelerate time 2  |                |      |               |
| P2.53         | Accelerate time 3  |                |      |               |
| P2.54         | Accelerate time 4  |                |      |               |
| P2.55         | Accelerate time 5  |                |      |               |
| P2.56         | Accelerate time 6  |                |      |               |
| P2.57         | Accelerate time 7  |                |      |               |
| P2.58         | Accelerate time 8  |                |      |               |
| P2.59         | Accelerate time 9  |                |      |               |
| P2.60         | Accelerate time 10 |                |      |               |
| P2.61         | Accelerate time 11 |                |      |               |
| P2.62         | Accelerate time 12 |                |      |               |
| P2.63         | Accelerate time 13 |                |      |               |
| P2.64         | Accelerate time 14 |                |      |               |
| P2.65         | Accelerate time 15 |                |      |               |

- Function: acceleration time setting

Principle explanation:

As shown in Figure 6-2-3, the acceleration time refers to the time required to accelerate from 0Hz to P6.13 motor frequency.

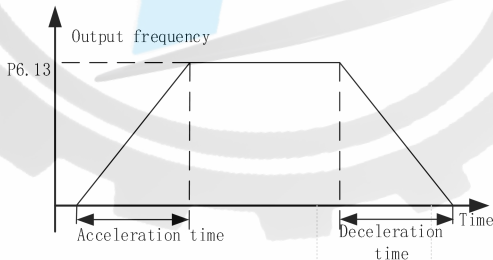

Figure 6-2-3 Acceleration and deceleration

| Parameter NO. | Parameter Name        | Setting range  | Unit | Factory value |
|---------------|-----------------------|----------------|------|---------------|
| P2.66         | Jog acceleration time | 0.050~3600.000 | S    | 5.000         |

- Function: Set Jog acceleration time

| Parameter NO. | Parameter Name              | Setting range | Unit | Factory value |
|---------------|-----------------------------|---------------|------|---------------|
| P2.68         | S curve acceleration time 1 | 0.000~100.000 | %    | 0.000         |
| P2.69         | S curve acceleration time 2 |               |      |               |

- Function: Set S curve acceleration time

Principle explanation:

S-curve acceleration is relatively smooth. When the reference frequency is approached, the acceleration is automatically adjusted to avoid exceeding the rated frequency of the motor.

Note: When P2.68 and P2.89 are not 0, S curve acceleration and deceleration are effective.

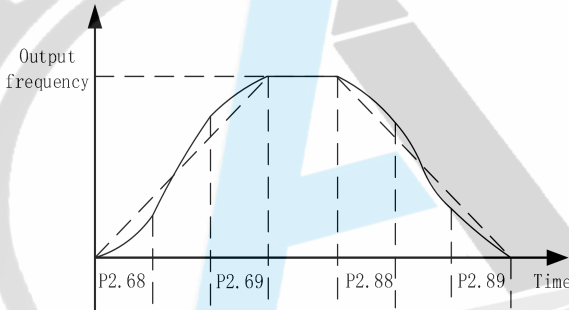

Figure 6-2-4 S curve acceleration and deceleration

| Parameter NO. | Parameter Name      | Setting range  | Unit | Factory value |
|---------------|---------------------|----------------|------|---------------|
| P2.70         | Deceleration time 0 | 0.050~3600.000 | S    | *             |
| P2.71         | Deceleration time 1 |                |      |               |
| P2.72         | Deceleration time 2 |                |      |               |
| P2.73         | Deceleration time 3 |                |      |               |
| P2.74         | Deceleration time 4 |                |      |               |
| P2.75         | Deceleration time 5 |                |      |               |
| P2.76         | Deceleration time 6 |                |      |               |
| P2.77         | Deceleration time 7 |                |      |               |
| P2.78         | Deceleration time 8 |                |      |               |
| P2.79         | Deceleration time 9 |                |      |               |

## H1 series vector control inverter manual V1.0

|       |                      |  |  |  |
|-------|----------------------|--|--|--|
| P2.80 | Deceleration time 10 |  |  |  |
| P2.81 | Deceleration time 11 |  |  |  |
| P2.82 | Deceleration time 12 |  |  |  |
| P2.83 | Deceleration time 13 |  |  |  |
| P2.84 | Deceleration time 14 |  |  |  |
| P2.85 | Deceleration time 15 |  |  |  |

- Function: Set deceleration time

Principle explanation:

As shown in Figure 6-2-3, the deceleration time refers to the time required to decelerate from P6.13 motor frequency to 0Hz.

| Parameter NO. | Parameter Name         | Setting range  | Unit | Factory value |
|---------------|------------------------|----------------|------|---------------|
| P2.86         | Jog deceleration time  | 0.050~3600.000 | S    | 5.000         |
| P2.87         | Safe deceleration time |                |      |               |

- Function: Set Jog deceleration time and safe deceleration time (Jog command see P3.03, safe stop command see P3.06)

| Parameter NO. | Parameter Name              | Setting range | Unit | Factory value |
|---------------|-----------------------------|---------------|------|---------------|
| P2.88         | S curve deceleration time 1 | 0.000~100.000 | %    | 0.000         |
| P2.89         | S curve deceleration time 2 |               |      |               |

- Function: Set S curve deceleration time (see P2.68, P2.69)

| Parameter NO. | Parameter Name          | Setting range        | Unit | Factory value |
|---------------|-------------------------|----------------------|------|---------------|
| P2.90         | Communication set value | -1000.000~1000.000   | %    | 0.000         |
| P2.91         | Communication demand    | 0~4294967295(16 Hex) |      | 0             |
| P2.92         | Keyboard set value      | -1000.000~1000.000   | %    | 100.000       |
| P2.93         | Keyboard demand         | 0~4294967295(16 Hex) |      | 0             |

- Function: port between control command and set value, no need to set under normal circumstances, can be used for viewing

Table 6-2-2 Command control word table

| Command word (Bit) | Definition |
|--------------------|------------|
| 0                  | start up   |

|    |                         |
|----|-------------------------|
| 1  | Reverse                 |
| 2  | Start reverse           |
| 3  | JOG                     |
| 4  | stop                    |
| 5  | Emergency stop          |
| 6  | Safe stop               |
| 7  | Reset                   |
| 9  | Parameter self-learning |
| 10 | Jump                    |
| 11 | pause                   |
| 13 | UP (incremental)        |
| 14 | DOWN (decreasing)       |

### 03 parameters: input and output

| Parameter NO. | Parameter Name               | Setting range  | Unit | Factory value   |   |
|---------------|------------------------------|--|------|---|---|
| P3.00         | Start command source         | 0 ~ 4294967295<br>Single command source mode (P1.39 = 0):<br>0: No effect;<br>1: keyboard;<br>2: communication;<br>3: S1;<br>4: S2<br>...<br>17 ~ 32: The 0 ~ 15 bits of P1.30 |      | 1   |   |
| P3.01         | Reverse start command source |  |      | 0   |   |
| P3.02         | Reverse command source       |  |      | 0   |   |
| P3.03         | Jog command source           |  |      | 1   |   |
| P3.04         | Source of stop command       |  |      | 0   |   |
| P3.05         | Free parking order source    |  |      | 0   |   |
| P3.06         | Source of Safe Stop Command  |  |      | Multi-command source mode (P1.39 = 1):<br>Bit0: keyboard;<br>Bit1: communication; | 0 |
| P3.07         | Reset command source         |  |      | Bit2: S1;<br>Bit3: S2;<br>...;  | 1 |
| P3.08         | Source of fault command      |  |      | Bit16 ~ Bit31: The 0 ~ 15 bits of P1.30   | 0 |
| P3.09         | Source of pause order        |  | 0    |   |   |

- Function: Select the command source (when the corresponding command source is selected as the keyboard, the reverse command, Jog command, and free stop command are all derived from the custom key M)

Reverse start-command: set value is reversed, and start-command is send.

Reverse command: set value is reversed.

Jog command: Jog function. The priority is greater than the start command and lower than the stop command.

Safe stop: stop according to the safe deceleration time (P2.87). The priority is higher than the stop command and lower than the free stop command.

Fault command: send out a fault signal and the inverter will stop freely.

Pause command: The inverter stops freely, but the operating bit in the status word remains.

Principle explanation:

P1.39 = 0 is single command source mode, P3.00 ~ P3.09 commands select a single source, index number 0: no effect; 1: keyboard; 2: communication,.... For example, when P3.00 = 3, the start command comes from S1. The operation of the host computer needs to select communication, and the single command function is effective.

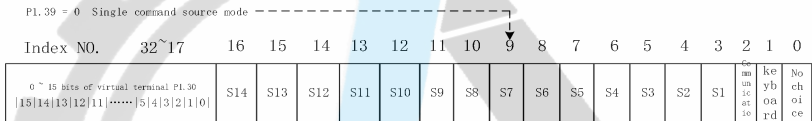

Figure 6-3-1 Single command source mode

P1.39 = 1 is multi-command source mode, P3.00 ~ P3.09 commands can select multiple sources, set bit selection bit0: keyboard, bit1: communication, ... For example, when P3.00 = 7 (binary 111), there are three ways to start the command source, which are keyboard, communication, and S1. The operation of the host computer needs to select communication, and the multi-command function is effective.

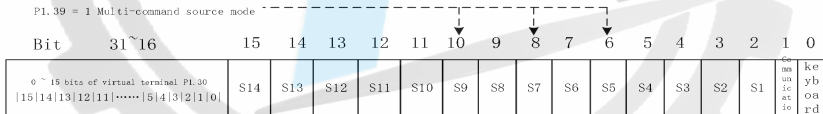

Figure 6-3-2 Multi-command source mode

| Parameter NO. | Parameter Name | Setting range  | Unit | Factory value |
|---------------|----------------|--|------|---------------|
| P3.20         | S1 type        | 0: positive logic;<br>1: Reverse logic;<br>2: Rising edge;<br>3: Falling edge; |      | 0             |
| P3.21         | S2 type        |  |      |               |
| P3.22         | S3 type        |  |      |               |
| P3.23         | S4 type        |  |      |               |
| P3.24         | S5 type        |  |      |               |
| P3.25         | S6 type        |  |      |               |
| P3.26         | S7 type        |  |      |               |

|       |         |  |  |
|-------|---------|--|--|
| P3.27 | S8 type |  |  |
|-------|---------|--|--|

- Function: select external terminal trigger type

**Principle explanation:**

- 0: positive logic, high level is valid state, low level is invalid state;
- 1: reverse logic, high level is invalid state, low level is valid state;
- 2: rising edge, rising edge is valid;
- 3: Falling edge, falling edge is valid.

**Two-wire mode 1:**

This mode is the most commonly used two-wire mode with enable and direction in one. The switch signals K1 and K2 determine the forward and reverse rotation of the motor.

Table 6-3-1

| Parameter No | Setting value | Note  |
|--------------|---------------|---|
| P3.00        | 3             | The source of the start command is S1         |
| P3.01        | 4             | The source of the reverse start command is S2 |
| P3.20        | 0             | S1 type is positive logic                     |
| P3.21        | 0             | S2 type is positive logic                     |

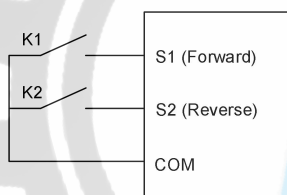

| K1  | K2  | Operate command |
|-----|-----|-----------------|
| OFF | OFF | Stop            |
| OFF | ON  | Reverse         |
| ON  | OFF | Forward         |
| ON  | ON  | Stop            |

Figure 6-3-3

**Two-wire mode 2:**

The enable is separated from the direction. In this mode, K1 is the running enable terminal, and the direction is determined by K2.

Table 6-3-2

| Parameter No | Setting value | Note  |
|--------------|---------------|---|
| P3.00        | 3             | The source of the start command is S1         |
| P3.02        | 4             | The source of the reverse start command is S2 |
| P3.20        | 0             | S1 type is positive logic                     |
| P3.21        | 0             | S2 type is positive logic                     |

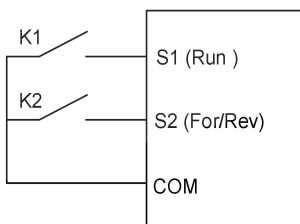

| K1  | K2  | Operate command |
|-----|-----|-----------------|
| OFF | OFF | Stop            |
| OFF | ON  | Stop            |
| ON  | OFF | Forward         |
| ON  | ON  | Reverse         |

Figure 6-3-4

**Three-wire control mode 1:**

This mode defines SB2 as an enable terminal, the running command is generated by SB1 or SB3, and controls the running direction at the same time. Inverter operation SB2 is in a closed state, and terminal SB1 or SB2 generates a rising edge signal to control the inverter operation and direction; when the inverter stops, it is necessary to disconnect terminal SB2 to complete the shutdown.

Table 6-3-3

| Parameter No | Setting value | Note  |
|--------------|---------------|---|
| P3.00        | 3             | The source of the start command is S1         |
| P3.01        | 5             | The source of the reverse start command is S3 |
| P3.04        | 4             | The source of the stop command is S2          |
| P3.20        | 2             | S1 type is rising edge                        |
| P3.21        | 1             | S2 type is reverse logic                      |
| P3.22        | 2             | S3 type is rising edge                        |

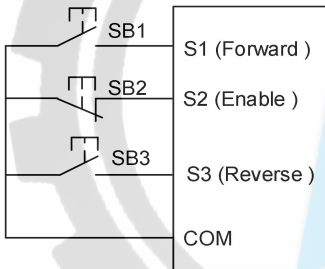

| SB1 | SB2 | SB3 | Operate command |
|-----|-----|-----|-----------------|
| —   | 0   | —   | Stop            |
| ↑   | 1   | —   | Forward         |
| —   | 1   | ↑   | Reverse         |

figure 6-3-5

**Three-wire control mode 2:**

This mode defines SB2 as an enable terminal, the run command is generated by button SB1, and the direction command is controlled by switch K. When the inverter is running, terminal SB2 needs to be in the closed state. Terminal SB1 generates a rising edge signal. The inverter starts to run. The state of switch K determines the running direction. When the inverter stops, terminal SB2 needs to be disconnected to complete the shutdown.

Table 6-3-4

| Parameter No | Setting value | Note  |
|--------------|---------------|---|
| P3.00        | 3             | The source of the start command is S1         |
| P3.02        | 5             | The source of the reverse start command is S3 |
| P3.04        | 4             | The source of the stop command is S2          |
| P3.20        | 2             | S1 type is rising edge                        |
| P3.21        | 1             | S2 type is reverse logic                      |

|       |   |                        |
|-------|---|------------------------|
| P3.22 | 0 | S3 type is rising edge |
|-------|---|------------------------|

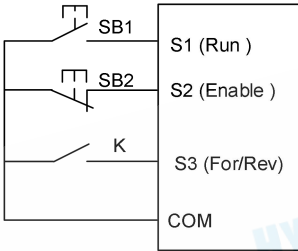

| SB1 | SB2 | K   | Operate command |
|-----|-----|-----|-----------------|
| —   | 0   | —   | Stop            |
| ↑   | 1   | OFF | Forward         |
| ↑   | 1   | ON  | Reverse         |

Figure 6-3-6

| Parameter NO. | Parameter Name           | Setting range   | Unit | Factory value |
|---------------|--------------------------|---|------|---------------|
| P3.28         | S Input filtering        | 1 ~ 16  |      | 2             |
| P3.29         | Start signal enable mode | 0: always enabled;<br>1: need to re-enable after power on;<br>2: After free-stop or safe-stop, it needs to be re-enabled;<br>3: After power-on, free stop or safe stop, you need to re-enable |      | 0             |

- Function: Control S terminal input effect and enable mode

S input filtering: S input signal is filtered, the larger the parameter value setting, the more obvious the filtering effect.

Start signal enable mode: When the start command comes from the external terminal, the safety of the inverter is improved.

Set parameter P3.29 to 0. During power-up, the inverter detects that the start command terminal is valid, and the inverter starts immediately.

Set parameter P3.29 to 1. During power-up, even if the inverter detects that the start command terminal is valid, the inverter will not start. Only when the terminal is re-enabled, the inverter can start.

Set parameter P3.29 to 2. After free stop or safe stop, even if the inverter detects that the start command terminal is valid, the inverter will not start. Only the terminal terminal is enabled again, the inverter can start.

Set parameter P3.29 to 3, the terminal needs to be re-enabled after power-on, free stop or safe stop before the inverter can start.

| Parameter NO. | Parameter Name | Setting range | Unit | Factory value |
|---------------|----------------|---------------|------|---------------|
|---------------|----------------|---------------|------|---------------|

|       |  |   |  |   |
|-------|--|---|--|---|
| P3.30 | Y1 terminal source(RA、RB<br>或 RA1、RB1) | 0: Always 0;<br>1: Always 1;<br>2: Stopped;<br>3: Running;<br>4: Fault;<br>5: Warning;<br>6: Reversing;<br>7: Ready;<br>64: STO state;<br>100 ~ 9999: address |  | 3 |
| P3.31 | Y1 terminal source Bit                 | 0~31  |  | 0 |
| P3.32 | Y2 terminal source<br>(RA2、RB2)        | 0: Always 0;<br>1: Always 1;<br>2: Stopped;<br>3: Running;<br>4: Fault;<br>5: Warning;<br>6: Reversing;<br>7: Ready;<br>64: STO state;<br>100 ~ 9999: address |  | 4 |
| P3.33 | Y2 terminal source bit                 | 0~31  |  | 0 |
| P3.34 | Y3 terminal source<br>(RA3、RB3、RC3)    | 0: Always 0;<br>1: Always 1;<br>2: Stopped;<br>3: Running;<br>4: Fault;<br>5: Warning;<br>6: Reversing;<br>7: Ready;<br>64: STO state;<br>100 ~ 9999: address |  | 5 |
| P3.35 | Y3 terminal source Bit                 | 0~31  |  | 0 |

- Function: Select the signal source of the digital output terminal

Principle explanation:

The terminal source setting value is greater than or equal to 100 (address mode), the address is the selected parameter number, and the actual value is determined by the current value of the selected parameter number. Bit source of terminal source is set bit selection. When terminal source is address 100 ~ 9999, the bit setting is valid. The terminal source setting value is less than 100 (non-address mode), and the terminal source Bit need not be set. The function description of the terminal source is as follows:

Table 6-3-5

| Parameter No | Setting value | Note   |
|--------------|---------------|--|
| 0            | Always 0      | Y terminal output is always 0                |
| 1            | Always 1      | Y terminal output is always 1                |
| 2            | stopped       | In the stopped state, Y terminal output is 1 |
| 3            | running       | In the running state, Y terminal output is 1 |
| 4            | Fault         | In the fault state, Y terminal output is 1   |
| 5            | Warning       | In the warning state, Y terminal output is 1 |

|          |            |  |
|----------|------------|--|
| 6        | Reversing  | In reverse state,Y terminal output is 1    |
| 7        | Ready      | In the ready state, Y terminal output is 1 |
| 64       | STO status | In STO state ,Y terminal output is 1       |
| 100~9999 | address    | Select parameters as Y output source       |

| Parameter NO. | Parameter Name       | Setting range  | Unit | Factory value |
|---------------|----------------------|----------------|------|---------------|
| P3.36         | Y1 output delay time | 0.000~6000.000 | S    | 0.000         |
| P3.37         | Y2 output delay time |                |      | 0.000         |
| P3.38         | Y3 output delay time |                |      | 0.000         |

- Function: Set Y1, Y2, Y3 output delay time

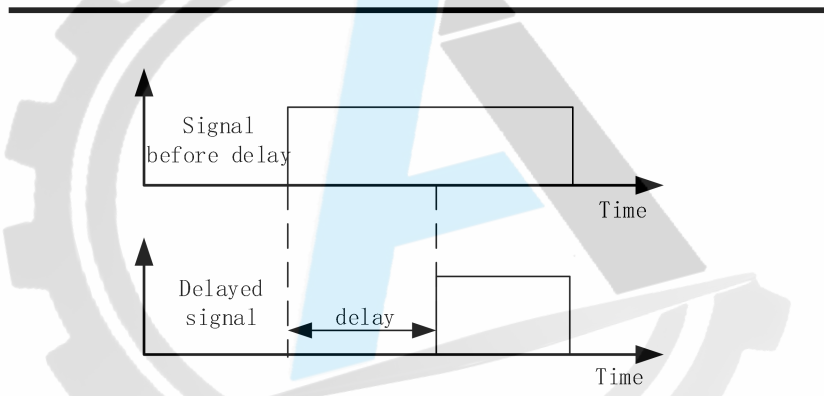

Figure 6-3-7 Y output delay

| Parameter NO. | Parameter Name | Setting range | Unit | Factory value |
|---------------|----------------|---------------|------|---------------|
| P3.39         | AI filter time | 0.100~600.000 | S    | 0.100         |

- Function: Set AI filter time

Principle explanation:

Adjust the sensitivity of the analog input, and increase the value appropriately to enhance the anti-interference of the analog, but it will reduce the sensitivity of the analog input.

| Parameter NO. | Parameter Name  | Setting range     | Unit | Factory value |
|---------------|-----------------|-------------------|------|---------------|
| P3.40         | AI1 signal type | 0: voltage input; |      | 0             |

|       |                                |                        |       |        |
|-------|--------------------------------|------------------------|-------|--------|
|       |                                | 1: current input       |       |        |
| P3.41 | AI1 low-end voltage (current)  | -999999.000~999999.000 | V(mA) | 0.000  |
| P3.42 | AI1 high-end voltage (current) |                        |       | 10.000 |
| P3.43 | AI1 low-end setting            |                        | %     | 0.000  |

Function: Analog input AI1 setting

- **AI1 signal type:** select input signal type, set value is 0, voltage signal input; set value is 1, current signal input.
- **AI1 low-end voltage (current):** set the minimum voltage (current) of the input signal.
- **AI1 high-end voltage (current):** set the maximum voltage (current) of the input signal.
- **AI1 low-end setting:** set the corresponding value of low-end voltage (current).
- **AI1 high-end setting:** set the corresponding value of high-end voltage (current).

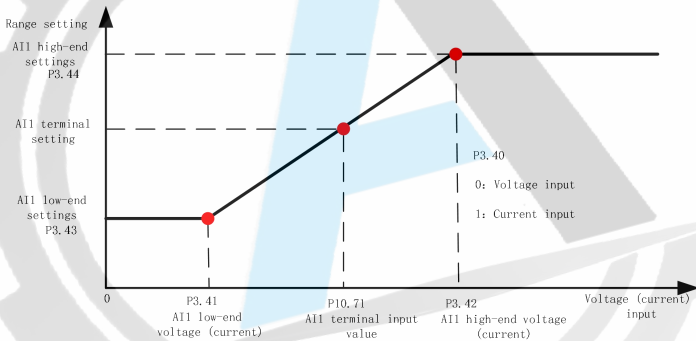

Figure 6-3-8 AI setting

| Parameter NO. | Parameter Name                 | Setting range                         | Unit  | Factory value |
|---------------|--------------------------------|---------------------------------------|-------|---------------|
| P3.45         | AI2 signal type                | 0: voltage input;<br>1: current input |       | 0             |
| P3.46         | AI2 low-end voltage (current)  | -999999.000~999999.000                | V(mA) | 0.000         |
| P3.47         | AI2 high-end voltage (current) |                                       |       | 10.000        |
| P3.48         | AI2 low-end setting            |                                       | %     | 0.000         |
| P3.49         | AI2 high-end setting           |                                       |       | 100.000       |

Function: Analog input AI2 setting

For details, please refer to P3.40 ~ P3.44.

| Parameter NO. | Parameter Name                 | Setting range  | Unit  | Factory value |
|---------------|--------------------------------|--|-------|---------------|
| P3.60         | AO1 signal type                | 0: voltage output;<br>1: current output  |       | 0             |
| P3.61         | AO1 signal source              | 0: always 0;<br>1: Always 10V / 20mA;<br>2: Output frequency;<br>3: Motor current;<br>4: Output voltage;<br>5: Motor torque;<br><br>6: Output power;<br>7: Set frequency;<br>100 ~ 9999: quote the value of the parameter number |       | 2             |
| P3.62         | AO1 low-end setting            | -999999.000~999999.000   | %     | 0.000         |
| P3.63         | AO1 high-end settings          |  |       | 50.000        |
| P3.64         | AO1 low-end voltage (current)  |  | V(mA) | 0.000         |
| P3.65         | AO1 high-end voltage (current) | 10.000   |       |               |

- Function: Analog output AO1 setting

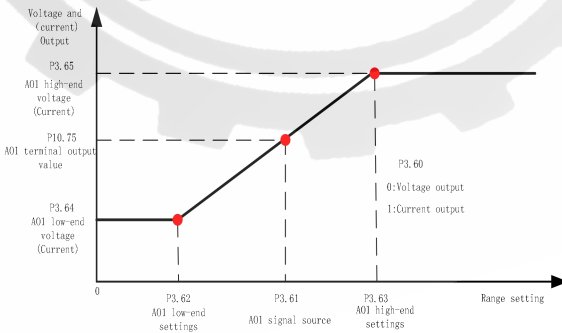

Figure 6-3-9 AO setting

AO1 signal type: select the output signal type, set value is 0, voltage signal output; set value is 1, current signal output.

## H1 series vector control inverter manual V1.0

AO1 signal source: select the signal source of AO output, 0: always 0; 1: always 10V / 20mA; 2: output frequency; ...

AO1 low-end setting: set the minimum value of AO1 source.

AO1 high-end setting: set the maximum value of AO1 source.

AO1 low-end voltage (current): set the minimum voltage (current) of the output signal.

AO1 high-end voltage (current): set the maximum voltage (current) of the output signal.

Principle explanation:

As shown in Fig. 6-3-9, set the AO1 signal source, check the P10.75 (AO1 terminal output value) of the

AO1 terminal output value, or measure with a multimeter. The function description of AO1 signal source is as

follows:

Table 6-3-6

| Parameter No | Setting value      | Note  |
|--------------|--------------------|---|
| 0            | Always 0           | Analog AO1 output has been 0                        |
| 1            | Always 10V / 20mA  | Analog AO1 output has been 10V / 20mA               |
| 2            | Output frequency   | Analog AO1 output is output frequency               |
| 3            | Motor current      | Analog AO1 output is motor current                  |
| 4            | The output voltage | Analog AO1 output is output voltage                 |
| 5            | Motor torque       | Analog AO1 output is motor torque                   |
| 6            | Output Power       | Analog AO1 output is output power                   |
| 7            | Set frequency      | Analog AO1 output is set frequency                  |
| 100~9999     | Parameter number   | Select parameter as the source of analog AO1 signal |

| Parameter NO. | Parameter Name                 | Setting range  | Unit  | Factory value |
|---------------|--------------------------------|--|-------|---------------|
| P3.66         | AO2 signal type                | 0: voltage output;<br>1: current output  |       | 0             |
| P3.67         | AO1 signal source              | 0: always 0;<br>1: Always 10V / 20mA;<br>2: Output frequency;<br>3: Motor current;<br>4: Output voltage;<br>5: Motor torque;<br><br>6: Output power;<br>7: Set frequency;<br>100 ~ 9999: quote the value of the parameter number |       | 3             |
| P3.68         | AO2 low-end setting            | -999999.000~999999.000   | %     | 0.000         |
| P3.69         | AO2 high-end settings          |  |       | 50.000        |
| P3.70         | AO2 low-end voltage (current)  |  | V(mA) | 0.000         |
| P3.71         | AO2 high-end voltage (current) |  |       | 10.000        |

- Function: Analog output AO2 setting

➤ For details, please refer to P3.60 ~ P3.65.

### Group 04 parameters: PID control

| Parameter NO. | Parameter Name                   | Setting range      | Unit | Factory value |
|---------------|----------------------------------|--------------------|------|---------------|
| P4.00         | PID proportional gain            | 0.000~10.000       | %    | 0.010         |
| P4.01         | PID integration time             | 0.001~9999.000     | S    | 10.000        |
| P4.02         | PID differential gain            | 0.000~9999.000     | %    | 0.000         |
| P4.03         | PID forward feedback coefficient | 0~500              | %    | 0             |
| P4.04         | PID sampling time                | 0.001~9999.000     | S    | 0.004         |
| P4.05         | PID output upper limit           | -1000.000~1000.000 | %    | 100.000       |
| P4.06         | PID output lower limit           | -1000.000~1000.000 | %    | 0.000         |
| P4.07         | PID output filter time           | 0.000~600.000      | S    | 0.000         |
| P4.09         | PID range                        | 0.001~99999.000    |      | 100.000       |

- Function: Simple PID control, enable PID control when P2.13 or P2.14 is set to 8

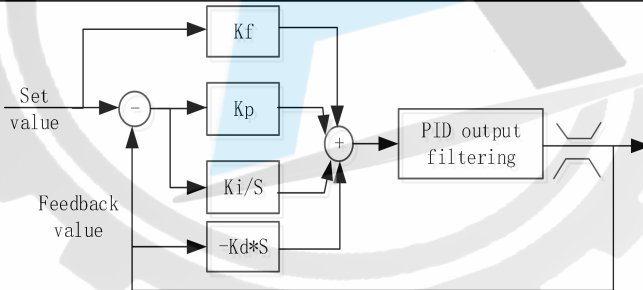

Figure 6-4-1 PID closed loop control

**PID proportional gain:** Determine the adjustment intensity of the entire PID regulator. The greater the proportional gain, the greater the adjustment intensity.

**PID integration time:** determine the speed of PID regulator to adjust the deviation of PID feedback and given amount. The smaller the integration time, the greater the adjustment intensity.

**PID differential gain:** determine the strength of PID regulator to adjust the deviation rate of PID feedback and given amount. The greater the differential gain, the greater the adjustment intensity.

**PID feedforward coefficient:** generally use a smaller feedforward coefficient; otherwise, use a larger feedforward coefficient to make feedforward adjustment play a major role.

**PID sampling time:** generally set 5 ~ 10 times smaller than the response time of the controlled object.

## H1 series vector control inverter manual V1.0

PID output upper limit: the maximum value of PID adjustment output, higher than the maximum value, PID output upper limit.

PID output lower limit: the minimum value of PID adjustment output, below the minimum value, PID output lower limit.

PID output filtering time: The filtering time increases, weakens the output signal mutation, and reduces the closed-loop system response performance.

PID range: according to the actual feedback range setting, if the setting is less than the feedback range PID does not work.

Method of adjusting proportional gain and integration time:

First adjust the integration time to the minimum, set the differential gain to 0, observe the PID feedback value and adjust the PID proportional gain. Slowly increase the integration time, repeatedly adjust the two parameters of proportional gain and integration time according to the response of the PID feedback value, change the PID given value multiple times within the PID given range, and adjust the proportional gain and integration time until Achieve satisfactory performance within the entire working range. Differential gain can be adjusted according to the need of overshoot, in most cases the differential link is generally not used.

| Parameter NO. | Parameter Name         | Setting range   | Unit | Factory value |
|---------------|------------------------|---|------|---------------|
| P4.11         | PID sleep frequency    | 0.000~500.000   | %    | 0.000         |
| P4.12         | PID enters sleep time  | 0.000~3600.000  | S    | 0.000         |
| P4.13         | PID wake-up deviation  | 0.000~100.000   | %    | 0.000         |
| P4.14         | PID entry wake-up time | 0.000~3600.000  | S    | 0.000         |
| P4.15         | PID sleep action       | 0: do not sleep;<br>1: PID stop;<br>2: Slow down;<br>3: Free to stop;<br>4: Pause;<br>5: Lowest frequency operation |      | 0             |

- Function: PID control function selection

### Principle explanation:

As shown in Figure 6-4-2, the PID output value is less than the P4.11 sleep frequency. After the time set by the parameter P4.12 (PID enters sleep time), the PID enters sleep according to the sleep action; the PID wakeup value is greater than P4.13 wakeup Deviation (wake-up value = percentage of set value), after the time set by parameter P4.14 (PID enters wake-up time), PID restarts.

PID sleep frequency: set the sleep quasi-frequency.

PID wake up deviation: percentage based on setting. For example, when 10 kg is set and the wake-up deviation is 20%, the wake-up deviation is 2 kg (20% × 10). When the actual pressure is less than 8 kg, the wake-up state starts.

PID enters sleep time: the inverter will enter sleep after reaching the sleep frequency and meeting the sleep time.

PID enters the wake-up time: the inverter will restart after reaching the wake-up deviation and meeting the wake-up time.

PID sleep action selection: PID enters sleep according to the set sleep action.

0 Do not sleep: PID operation is not changed.

- 1 PID stop: PID stops working.
- 2 Deceleration stop: The inverter decelerates to stop.
- 3 Free stop: The inverter freely stops.
- 4 Pause: The inverter pauses.
- 5 Lowest frequency operation: run at the lowest frequency, see parameter P4.06 (PID output lower limit frequency) for lowest frequency setting.

**Note:** When the PID sleep action selects deceleration stop or free stop, sleep will cause the start signal to be cleared once. Therefore: when the start signal comes from the keyboard, the start signal will be cleared after sleep. If the automatic wake-up function is required, select PID to stop or pause or the lowest frequency operation for PID sleep action. When the start signal comes from the S terminal input or communication (the communication continues to send the start signal), the PID sleep action will not affect the PID wakeup.

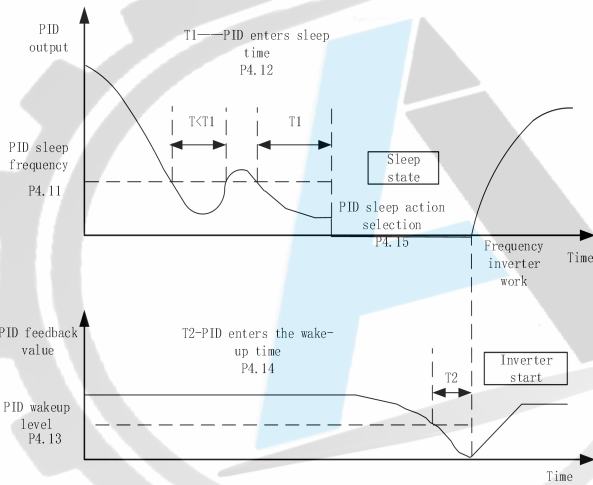

Figure 6-4-2 PID Wake up from sleep

| Parameter NO. | Parameter Name | Setting range | Unit | Factory value |
|---------------|----------------|---------------|------|---------------|
| P4.90         | PID status     | 0~4294967295  |      |               |

Function: indicates the PID status word (see the table below for the definition of each bit).

Table 6-4-1

| Status word (Bit) | Definition        |
|-------------------|-------------------|
| 0                 | PID is stopped    |
| 1                 | PID is running    |
| 5                 | PID goes to sleep |

### Group 05 parameters: system control

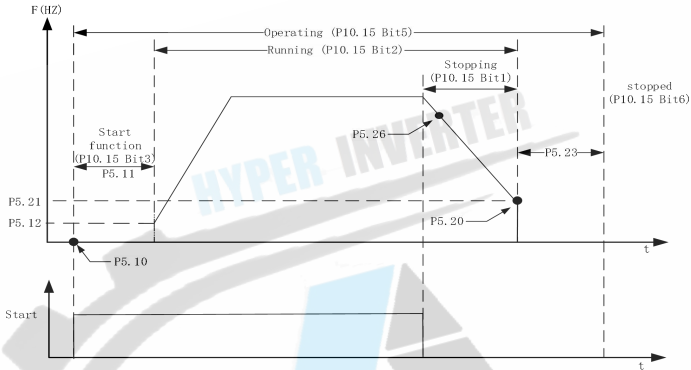

Figure 6-5-1 System control

| Parameter NO. | Parameter Name | Setting range                   | Unit | Factory value |
|---------------|----------------|---------------------------------|------|---------------|
| P5.00         | Control mode   | 0: VF;<br>1: Open loop vector 1 |      | 1             |

- Function: Select motor control algorithm

| Parameter NO. | Parameter Name                     | Setting range  | Unit | Factory value |
|---------------|------------------------------------|----------------|------|---------------|
| P5.06         | Forward and reverse switching time | 0.000~6000.000 | S    | 0.000         |

- Function: control forward and reverse switching dead time

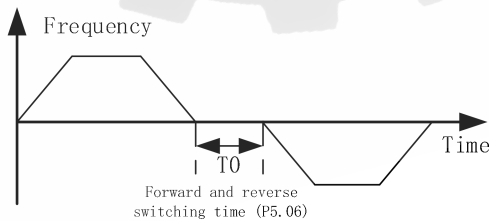

Figure 6-5-2 Switching between forward and reverse

| Param | Parameter Name | Setting range | Un | Factory |
|-------|----------------|---------------|----|---------|
|-------|----------------|---------------|----|---------|

## H1 series vector control inverter manual V1.0

| Parameter NO. | Parameter Name          | Setting range                               | Unit | Factory value |
|---------------|-------------------------|---|------|---------------|
| P5.07         | Forced change direction | 0: No effect;<br>1: forced change direction |      | 0             |

- Function: control the commutation function, when the parameter P5.07 is set to 1, change the current running direction

| Parameter NO. | Parameter Name              | Setting range      | Unit | Factory value |
|---------------|-----------------------------|--------------------|------|---------------|
| P5.08         | Motor frequency upper limit | -1020.000~1020.000 | Hz   | 55.000        |

- Function: Motor output frequency limit

> Motor frequency upper limit: define the motor operating frequency upper limit.

| Parameter NO. | Parameter Name  | Setting range  | Unit | Factory value |
|---------------|-----------------|--|------|---------------|
| P5.10         | Start function  | 0: Start frequency operation;<br>1: On speed start;<br>2: DC injection |      | 0             |
| P5.11         | Start Time      | 0.000~60000.000  | S    | 0.000         |
| P5.12         | Start frequency | 0.000~100.000  | Hz   | 0.000         |

- Function: Set start function

Principle explanation:

When the system starts, it will work according to the set start function within the set start time. After the start function is over, if the set frequency is greater than the start frequency, the system starts to run at the start frequency; if the set frequency is less than the start frequency, the system starts to run at the set frequency.

Start function:

0: Start mode with no output frequency, meet the setting of P5.11 start time, P5.12 start frequency starts to start running.

1: Start flying, search the speed of the rotating motor, and start a smooth start without impact from the speed found.

2: DC injection, the inverter starts by "DC injection first".

| Parameter NO. | Parameter Name      | Setting range   | Unit | Factory value |
|---------------|---------------------|---|------|---------------|
| P5.14         | On speed start mode | 0: All directional;<br>1: Set value direction;<br>2 ~ 3: reserved |      | 0             |

- Function: Set the speed start function (set P5.10 to 1 speed start)

## H1 series vector control inverter manual V1.0

Speed start mode:

0: Two-way, follow the forward or reverse direction for speed tracking judgment.

1: Set value direction, follow the set direction for speed tracking judgment.

| Parameter NO. | Parameter Name       | Setting range | Unit | Factory value |
|---------------|----------------------|---------------|------|---------------|
| P5.19         | DC injection current | 0.000~200.000 | %    | 100.000       |

- Function: Set the DC injection current size (set P5.10 to 2 DC injection)

Principle explanation:

When the starting method is DC injection, the DC braking current needs to be set to 100% corresponding to the rated current of the inverter.

| Parameter NO. | Parameter Name | Setting range  | Unit | Factory value |
|---------------|----------------|--|------|---------------|
| P5.20         | Stop function  | Units: 0: free parking;<br>1: DC braking;<br>Ten: 1: precise parking |      | 0             |
| P5.21         | Stop frequency | 0.000~1000.000   | Hz   | 0.000         |

- Function: Set stop function

Principle explanation:

During the stop process, when the output frequency is less than the stop frequency, the stop function starts to work.

Precise parking: The motor rotates the same number of revolutions at any speed to achieve consistent repeatability of the parking position. To achieve the best results, the deceleration time should be as long as possible so as not to trigger the overvoltage and overcurrent stall prevention functions.

| Parameter NO. | Parameter Name             | Setting range  | Unit | Factory value |
|---------------|----------------------------|----------------|------|---------------|
| P5.22         | DC braking current         | 0.000~150.000  | %    | 100.000       |
| P5.23         | DC braking time            | 0.000~1000.000 | S    | 0.000         |
| P5.24         | Demagnetization time ratio | 0.000~1000.000 | %    | 10.000        |

- Function: Set the DC braking parameters of the stop function

DC braking current: set the DC braking current.

DC braking time: set the DC braking time.

Demagnetization time ratio: Generally, no modification is required. For occasions requiring accurate positioning and strict deceleration time, reduce the demagnetization time ratio; where the requirements for deceleration time are not strict, appropriately increase the demagnetization time ratio to reduce the deceleration current impact.

| Parameter NO. | Parameter Name                           | Setting range  | Unit | Factory value |
|---------------|--|----------------|------|---------------|
| P5.26         | Magnetic flux brake activation frequency | 0.000~1000.000 | Hz   | 0.000         |

## H1 series vector control inverter manual V1.0

|       |                                   |                |   |       |
|-------|-----------------------------------|----------------|---|-------|
| P5.27 | Magnetic Flux braking coefficient | 100~200        | % | 100   |
| P5.28 | Magnetic Flux braking time        | 0.000~1000.000 | S | 0.000 |

- Function: Set the flux braking parameters of the stop function

### Principle explanation:

During the stop, when the output frequency is less than the flux braking activation frequency, the flux braking function starts to take effect during the flux braking time. Flux braking is generally used in situations that require rapid deceleration, but excessive use will cause the motor to heat up.

| Parameter NO. | Parameter Name        | Setting range                         | Unit | Factory value |
|---------------|-----------------------|---------------------------------------|------|---------------|
| P5.30         | Brake resistance mode | 0: invalid;<br>1: Maximum duty cycle; |      | 1             |

- Function: Braking resistor braking mode parameter setting

| Parameter NO. | Parameter Name  | Setting range | Unit | Factory value |
|---------------|-----------------|---------------|------|---------------|
| P5.50         | Auto reset mode | 0~9999        |      | 0             |
| P5.51         | Auto reset time | 0.000~600.000 | S    | 10.000        |

- Function: Set automatic reset function

### Principle explanation:

If the parameter P5.50 is not 0, the automatic reset function is valid, the number of automatic resets is the set value of P5.50, and the automatic reset time is the time when the fault is delayed. If P5.50 is set to 9999, it can be reset any number of times. If P5.50 is set greater than 0 and less than 9999, when the number of automatic resets exceeds P5.50, the inverter will report a fault.

| Parameter NO. | Parameter Name                          | Setting range | Unit | Factory value |
|---------------|---|---------------|------|---------------|
| P5.60         | Automatic energy saving minimum flux    | 30~100        | %    | 100           |
| P5.61         | Automatic energy saving start frequency | 0~200.000     | Hz   | 5.000         |

- Function: Set automatic energy saving function

### Principle explanation:

Automatic energy saving automatically adjusts the output voltage according to the motor load to achieve the purpose of energy saving. When P6.70 is set to 1, P5.60 set value is less than 100 and the running frequency is greater than P5.61, the automatic energy saving function is effective.

| Parameter | Parameter Name | Setting range | Unit | Factory value |
|-----------|----------------|---------------|------|---------------|
|-----------|----------------|---------------|------|---------------|

| NO.   |                                    |       |   |    |
|-------|------------------------------------|-------|---|----|
| P5.63 | Manual energy-saving magnetic flux | 30~90 | % | 70 |

- Function: Set manual energy-saving magnetic flux size

**Principle explanation:**

When P6.70 is set to 1 and the automatic energy saving function is invalid, manual energy saving is effective. If P5.63 is set to 100, manual energy saving is invalid. Adjust the energy saving effect by setting the parameter P5.63 magnetic flux size. The smaller the set value, the more obvious the energy saving effect, but the torque response speed becomes slower.

| Parameter NO. | Parameter Name      | Setting range | Unit | Factory value |
|---------------|---------------------|---------------|------|---------------|
| P5.71         | Current upper-limit | 0~300         | %    | 150           |

- Function: When the running current is greater than the upper current limit, the overcurrent stall function is activated. The current reference is the motor rated current (P6.14).

| Parameter NO. | Parameter Name                     | Setting range | Unit | Factory value |
|---------------|------------------------------------|---------------|------|---------------|
| P5.76         | Upper limit of electric torque     | 0.000~900.000 | %    | 150.000       |
| P5.77         | Upper limit of regenerative torque | 0.000~900.000 | %    | 150.000       |

- Function: Set torque limit function

**Principle explanation:**

Parameters P5.76 and P5.77 set the upper limit of electric and regenerative torque.

| Parameter NO. | Parameter Name                            | Setting range                        | Unit | Factory value |
|---------------|---|--------------------------------------|------|---------------|
| P5.80         | Over-voltage control                      | 0: invalid;<br>1: valid at all times |      | 1             |
| P5.82         | Over-voltage control scale factor         | 0~200                                | %    | 100           |
| P5.83         | Over-voltage control integral coefficient | 0~10000                              | %    | 100           |

- Function: Set overvoltage control function

**Principle explanation:**

When the regenerative voltage exceeds the set threshold, the overvoltage control starts to activate the overvoltage stall function according to the setting of parameter P5.80.

| Parameter NO. | Parameter Name           | Setting range  | Unit | Factory value |
|---------------|--------------------------|--|------|---------------|
| P5.85         | Under-voltage control    | Units: grid power-down action mode<br>0: invalid;<br>1: Instant stop;<br>2: Safe parking;<br>3 ~ 6: reserved<br>Tens: Under-voltage operation mode of power grid<br>0: invalid;<br>1: Safe frequency reduction |      | 0             |
| P5.86         | Power grid voltage level | 100~800  | V    | *             |

- Function: Set undervoltage control function

**Principle explanation:**

When the input voltage is lower than the grid power-down level, the power-down action starts to activate according to the parameter P5.85 bit setting. Grid undervoltage means that the grid voltage is lower than the normal voltage, and the undervoltage action starts to activate according to the parameter P5.85 tens place setting.

| Parameter NO. | Parameter Name              | Setting range   | Unit | Factory value |
|---------------|-----------------------------|---|------|---------------|
| P5.90         | AVR function selection      | 0: invalid;<br>1: valid;<br>2: Only invalid when decelerating |      | 1             |
| P5.91         | AVR function damping factor | 0~400   | %    | 100           |

- Function: Set AVR function

**Principle explanation:**

AVR is used to compensate the fluctuation of grid voltage and keep the output voltage constant. When P5.90 is selected as 2, it is conducive to rapid deceleration.

**Group 06 parameters: motor model**

| Parameter NO. | Parameter Name                | Setting range  | Unit | Factory value |
|---------------|-------------------------------|--|------|---------------|
| P6.00         | Motor self-learning parameter | 0: invalid<br>1: Complete self-learning<br>2: Simple self-learning |      | 0             |

- Function: Online learning of motor parameters

Principle explanation:

During complete self-learning and simple self-learning, the motor will not rotate. After self-learning, the parameters such as motor stator impedance and rotor impedance will change. Before motor parameter self-learning, input motor nameplate parameters P6.10 ~ P6.15.

Self-learning process: Set P6.00, press the run key to start self-learning. When the self-learning is normal, the keyboard displays L0. After the self-learning is completed, press the stop key to exit the self-learning and return to the normal state.

| Parameter NO. | Parameter Name    | Setting range | Unit | Factory value |
|---------------|-------------------|---------------|------|---------------|
| P6.05         | Carrier frequency | 2~16          | kHz  | *             |

- Function: Set carrier frequency

| Parameter NO. | Parameter Name           | Setting range        | Unit | Factory value |
|---------------|--------------------------|----------------------|------|---------------|
| P6.06         | Over-modulation function | 0: invalid; 1: valid |      | 1             |

- Function: Set over modulation function

| Parameter NO. | Parameter Name        | Setting range   | Unit    | Factory value |
|---------------|-----------------------|---|---------|---------------|
| P6.10         | Motor type            | 0: Asynchronous motor;<br>1: Surface mount permanent magnet synchronization;<br>2: Salient pole permanent magnet synchronization<br>4: single-phase motor |         | 0             |
| P6.11         | Motor Power           | 0.000~100000.000  | kW      | *             |
| P6.12         | Motor voltage         | 0~1000  | V       | *             |
| P6.13         | Motor frequency       | 1~3000  | Hz      | *             |
| P6.14         | Motor current         | 0.00~1000.00  | A       | *             |
| P6.15         | Motor speed           | 10~65535  | RP<br>M | *             |
| P6.16         | Motor power factor    | 0.00~1.00   |         | *             |
| P6.17         | Number of motor poles | 2~100   |         | *             |
| P6.18         | Motor rated torque    | 0.1~10000.0   | NM      | *             |
| P6.19         | Motor no-load current | 0.00~1000.00  | A       | *             |

- Function: Set motor parameters

## H1 series vector control inverter manual V1.0

| Parameter NO. | Parameter Name          | Setting range  | Unit   | Factory value |
|---------------|-------------------------|----------------|--------|---------------|
| P6.20         | PM motor back EMF / rev | 1.000~1000.000 | mV/rpm | *             |

- Function: Set the back EMF corresponding to the rated speed of the permanent magnet synchronous motor

| Parameter NO. | Parameter Name           | Setting range  | Unit     | Factory value |
|---------------|--------------------------|----------------|----------|---------------|
| P6.40         | Stator impedance         | 0.000~999.990  | $\Omega$ | *             |
| P6.41         | Rotor impedance          | 0.000~999.990  | $\Omega$ | *             |
| P6.42         | Stator leakage reactance | 0.000~9999.990 | mH       | *             |
| P6.44         | Motor main reactance     | 0.00~999.90    | mH       | *             |

- Function: Motor model parameters (obtained by self-learning of motor parameters)

| Parameter NO. | Parameter Name                             | Setting range  | Unit | Factory value |
|---------------|--|----------------|------|---------------|
| P6.50         | PM d-axis reactance                        | 0.000~1000.000 | mH   | *             |
| P6.51         | PM q-axis reactance                        | 0.001~9999.000 | mH   | *             |
| P6.52         | PM d 轴电抗饱和系数                               | 0.0~100.0      | %    | *             |
| P6.53         | PM q 轴电抗饱和系数                               | 0.0~100.0      | %    | *             |
| P6.54         | PM d-axis reactance saturation coefficient | 10~400         | %    | 100           |
| P6.55         | PM q axis reactance saturation coefficient | 10~400         | %    | 100           |

- Function: Permanent magnet synchronous motor model parameters (obtained by self-learning of motor parameters)

| Parameter NO. | Parameter Name                    | Setting range | Unit | Factory value |
|---------------|-----------------------------------|---------------|------|---------------|
| P6.60         | Maximum field weakening current d | 0.200 ~ 1.800 |      | 1.000         |

- Function: Set single-phase motor turn ratio

| Parameter NO. | Parameter Name | Setting range   | Unit | Factory value |
|---------------|----------------|---|------|---------------|
| P6.70         | Load type      | 0: constant torque;<br>1: fan water pump;<br>2: promotion;<br>3: reserved |      | 0             |

- Function: Select the appropriate load type to obtain the corresponding torque characteristics, optimize the control algorithm

| Parameter NO. | Parameter Name                    | Setting range                    | Unit | Factory value |
|---------------|-----------------------------------|----------------------------------|------|---------------|
| P6.80         | Motor cable compensation strength | 0: low;<br>1: medium;<br>2: high |      | 0             |

- Function: generally select 0 for unshielded wire;  
For shielded cables of about 15 meters, select 1;  
For longer shielded cable, select 2.

## Group 07 parameters: control algorithm

| Parameter NO. | Parameter Name                    | Setting range | Unit | Factory value |
|---------------|-----------------------------------|---------------|------|---------------|
| P7.50         | Slip compensation                 | -500~500      | %    | 100           |
| P7.51         | Slip compensation filter constant | 1~10000       | %    | 100           |

- Function: Set vector control slip compensation parameters
- Slip compensation: adjust the speed stability accuracy of the motor. When the motor is under heavy load, the speed is low, increase this parameter, otherwise reduce this parameter. (For the need of soft load, provide negative value selection)

| Parameter NO. | Parameter Name                         | Setting range | Unit | Factory value |
|---------------|--|---------------|------|---------------|
| P7.52         | Resonance suppression coefficient      | 0~10000       | %    | 100           |
| P7.53         | Low-speed suppression filter constant  | 1~10000       | %    | 100           |
| P7.54         | High-speed suppression filter constant | 1~10000       | %    | 100           |

- Function: Set resonance suppression coefficient, high and low speed suppression filter constant

**Principle explanation:**

The no-load frequency conversion control system is prone to resonance, and the resonance suppression function helps eliminate vibration.

| Parameter NO. | Parameter Name                     | Setting range | Unit | Factory value |
|---------------|------------------------------------|---------------|------|---------------|
| P7.55         | Automatic torque boost coefficient | 0~300         | %    | 100           |

- Function: Set automatic torque boost coefficient

**Principle explanation:**

According to the load, the output voltage at low frequency is automatically compensated to improve the load capacity at low frequency.

| Parameter NO. | Parameter Name                   | Setting range | Unit | Factory value |
|---------------|----------------------------------|---------------|------|---------------|
| P7.57         | Low speed minimum current        | 0~300         | %    | 50            |
| P7.58         | Static friction lift coefficient | 0~10000       | %    | 100           |
| P7.59         | Static friction lift time        | 0.0~1000.0    | S    | 0.0           |

- Function: Set low speed minimum current and static friction parameters

**Principle explanation:**

Low speed minimum current Given the minimum current at low speed, proper settings help to improve the low speed load capacity. The static friction lifting function automatically compensates the output voltage at the start according to the load, thereby increasing the starting torque.

| Parameter NO. | Parameter Name | Setting range | Unit | Factory value |
|---------------|----------------|---------------|------|---------------|
| P7.71         | VF curve-F1    | 0~3000        | Hz   | 50            |

|       |             |         |   |    |
|-------|-------------|---------|---|----|
| P7.72 | VF curve-F2 |         | V | 50 |
| P7.73 | VF curve-F3 |         |   | 50 |
| P7.74 | VF curve-F4 |         |   | 50 |
| P7.75 | VF curve-V0 | 0~10000 | V | 0  |
| P7.76 | VF curve-V1 |         |   | *  |
| P7.77 | VF curve-V2 |         |   | *  |
| P7.78 | VF curve-V3 |         |   | *  |
| P7.79 | VF curve-V4 |         |   | *  |

- Function: Set VF curve

Principle explanation:

Set the V / F curve in V / F control mode. When vector control 1 is used, the corresponding data points of the V / F curve can be set to adjust the control characteristics of the corresponding control points.

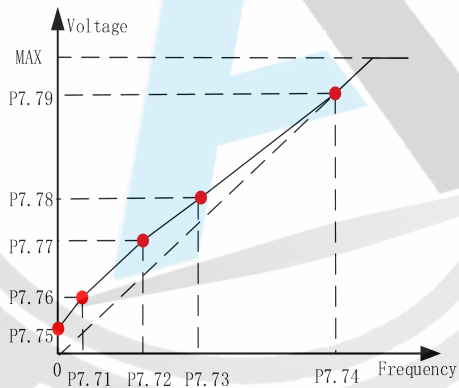

Figure 6-7-1 VF control curve

### Group 09 parameters: system protection

| Parameter NO. | Parameter Name          | Setting range                           | Unit | Factory value |
|---------------|-------------------------|---|------|---------------|
| P9.00         | Input phase loss action | 0: failure;<br>1: alarm;<br>2: invalid; |      | 2             |

- Function: Set input phase loss action

| Parameter NO. | Parameter Name              | Setting range           | Unit | Factory value |
|---------------|-----------------------------|-------------------------|------|---------------|
| P9.04         | Output phase loss detection | 0: invalid;<br>1: valid |      | 1             |

- Function: Set the action when output phase loss protection

| Parameter NO. | Parameter Name | Setting range                        | Unit | Factory value |
|---------------|----------------|--------------------------------------|------|---------------|
| P9.06         | ETR selection  | 0: invalid;<br>1: alarm;<br>2: fault |      | 2             |

- Function: Select ETR action

## Group 10 parameters: system status

| Parameter NO. | Parameter Name          | Setting range | Unit | Factory value |
|---------------|-------------------------|---------------|------|---------------|
| P10.05        | Software version number |               |      |               |

- Function: Indicate the inverter software version number.

| Parameter NO. | Parameter Name | Setting range | Unit | Factory value |
|---------------|----------------|---------------|------|---------------|
| P10.10        | Control word   | 0~4294967295  |      |               |

- Function: indicates the system control word. The definition of each bit is shown in the table below:

Table 6-9-1

| Control word (Bit) | Definition    |
|--------------------|---------------|
| 0                  | start up      |
| 1                  | Reverse       |
| 2                  | Start reverse |

# H1 series vector control inverter manual V1.0

|    |                         |
|----|-------------------------|
| 3  | JOG                     |
| 4  | stop                    |
| 5  | Emergency stop          |
| 6  | Safe stop               |
| 7  | Reset                   |
| 9  | Parameter self-learning |
| 10 | Jump                    |
| 11 | time out                |
| 13 | UP (incremental)        |
| 14 | DOWN (decreasing)       |

| Parameter NO. | Parameter Name | Setting range    | Unit | Factory value |
|---------------|----------------|------------------|------|---------------|
| P10.11        | Set value      | -65535.0~65535.0 |      |               |

- Function: Indicate the set frequency value, see Figure 6-2-1

| Parameter NO. | Parameter Name | Setting range | Unit | Factory value |
|---------------|----------------|---------------|------|---------------|
| P10.15        | Current status | 0~4294967295  |      |               |

- Function: Indicates the system status word (see the table below for the definition of each bit). The specific meaning is shown in Figure 6-5-1.

Table 6-9-2

| Control word (Bit) | Definition           |
|--------------------|----------------------|
| 0                  | Powering off         |
| 1                  | Stopping             |
| 2                  | running              |
| 3                  | Start function start |
| 4                  | Parameter self-study |
| 5                  | Operating            |
| 6                  | Ready                |
| 10                 | Fault                |
| 11                 | Error                |
| 12                 | STO status           |

| Parameter NO. | Parameter Name      | Setting range | Unit | Factory value |
|---------------|---------------------|---------------|------|---------------|
| P10.16        | Fault status word 1 | 0~4294967295  |      |               |
| P10.17        | Fault status word 2 | 0~4294967295  |      |               |

- Function: indicate the system fault status word (see the table below for the definition of each bit)

| Fault status word 1 (Bit) | Definition                   |
|---------------------------|------------------------------|
| 1                         | System abnormality           |
| 4                         | Ground fault                 |
| 5                         | Short circuit to ground      |
| 6                         | Output short circuit         |
| 7                         | Output overcurrent           |
| 8                         | DC bus overvoltage           |
| 9                         | DC bus undervoltage          |
| 10                        | Inverter overheating         |
| 11                        | Self-learning failure        |
| 13                        | Rectifier bridge overheating |
| 14                        | U phase missing phase        |
| 15                        | V Phase missing phase        |
| 16                        | W phase missing phase        |
| 19                        | No motor connection          |
| 20                        | Input phase loss             |
| 21                        | Inverter overload            |
| 22                        | Overtorque                   |
| 24                        | Motor overheating            |
| 25                        | Motor overload               |
| 26                        | Current limit                |
| 27                        | Input power down             |
| Fault status word 2 (Bit) | Definition                   |
| 31                        | External fault               |

| Parameter NO. | Parameter Name    | Setting range | Unit | Factory value |
|---------------|-------------------|---------------|------|---------------|
| P10.18        | Alarm status word | 0~4294967295  |      |               |

- Function: indicate the system alarm status word (see the description of the above table for the definition of each Bit)

| Parameter NO. | Parameter Name                  | Setting range    | Unit | Factory value |
|---------------|---------------------------------|------------------|------|---------------|
| P10.20        | Output frequency absolute value | 0.0~65535.0      | Hz   |               |
| P10.21        | Output frequency                | -65535.0~65535.0 | Hz   |               |
| P10.22        | Output current                  | 0.00~65535.00    | A    |               |
| P10.23        | Output voltage                  | 0.0~65535.0      | V    |               |

## H1 series vector control inverter manual V1.0

|        |               |                 |         |  |
|--------|---------------|-----------------|---------|--|
| P10.24 | Output torque | 0.000~65535.000 | N<br>.M |  |
|--------|---------------|-----------------|---------|--|

- Function: Indicate output information

| Parameter NO. | Parameter Name       | Setting range     | Unit     | Factory value |
|---------------|----------------------|-------------------|----------|---------------|
| P10.25        | DC voltage           | 0.0~65535.0       | V        |               |
| P10.26        | Inverter temperature | 0~65535           | °C       |               |
| P10.27        | Inverter hot load    | 0~65535           | %        |               |
| P10.28        | Motor hot load       | 0~65535           | %        |               |
| P10.30        | power                | 0.000~65535.000   | kw       |               |
| P10.31        | Energy consumption   | 0.000~4294967.295 | Kw*<br>h |               |

- Function: Indicate the running status information of the inverter

| Parameter NO. | Parameter Name     | Setting range     | Unit | Factory value |
|---------------|--------------------|-------------------|------|---------------|
| P10.40        | Hours of power on  | 0.000~4294967.295 | h    |               |
| P10.41        | Number of power-on | 0~4294967295      |      |               |

- Function: Instruct inverter statistics

| Parameter NO. | Parameter Name              | Setting range | Unit | Factory value |
|---------------|-----------------------------|---------------|------|---------------|
| P10.60        | Current alarm number        | 0~4294967295  |      |               |
| P10.61        | Current fault number        |               |      |               |
| P10.62        | Last fault number           |               |      |               |
| P10.63        | The first two fault numbers |               |      |               |

## H1 series vector control inverter manual V1.0

- Function: Indicate the inverter fault information, (refer to chapter 10.2 Troubleshooting)

| Parameter NO. | Parameter Name            | Setting range        | Unit | Factory value |
|---------------|---------------------------|----------------------|------|---------------|
| P10.70        | S input terminal status   | 0~4294967295         |      |               |
| P10.71        | AI1 terminal input value  | -65535.000~65535.000 | %    |               |
| P10.72        | AI2 terminal input value  | -65535.000~65535.000 | %    |               |
| P10.74        | Y terminal output status  | 0~4294967295         |      |               |
| P10.75        | AO1 terminal output value | -65535.000~65535.000 | %    |               |
| P10.76        | AO2 terminal output value | -65535.000~65535.000 | %    |               |

- Function: indicate external terminal information

| Parameter NO. | Parameter Name         | Setting range   | Unit | Factory value |
|---------------|------------------------|-----------------|------|---------------|
| P10.78        | Pulse input frequency  | 0.000~10000.000 | k Hz |               |
| P10.79        | Pulse output frequency | 0.000~10000.000 | k Hz |               |

- Function: Indicate pulse input and output frequency

| Parameter NO. | Parameter Name | Setting range      | Unit | Factory value |
|---------------|----------------|--------------------|------|---------------|
| P10.80        | Encoder count  | 0~4294967295       |      |               |
| P10.81        | Encoder speed  | -9999.000~9999.000 | Hz   |               |
| P10.82        | Encoder angle  | 0.0~359.9          | Deg  |               |

- Function: indicate encoder status

| Parameter NO. | Parameter Name | Setting range          | Unit | Factory value |
|---------------|----------------|------------------------|------|---------------|
| P10.90        | Set value 1    | -999999.000~999999.000 | %    |               |

## H1 series vector control inverter manual V1.0

|        |             |                        |   |  |
|--------|-------------|------------------------|---|--|
| P10.91 | Set value 2 | -999999.000~999999.000 | % |  |
| P10.92 | Set value 3 | -999999.000~999999.000 | % |  |

- Function: Indicate the set value, see Figure 6-2-1

| Parameter NO. | Parameter Name  | Setting range        | Unit | Factory value |
|---------------|-----------------|----------------------|------|---------------|
| P10.98        | Display value 1 | -99999.000~99999.000 |      |               |
| P10.99        | Display value 2 | -99999.000~99999.000 |      |               |

- Function: indicate the display value (see P1.68 ~ P1.69 for the source of the display value)

### Group 11 parameters: fault record

| Parameter NO. | Parameter Name                         | Setting range        | Unit | Factory value |
|---------------|--|----------------------|------|---------------|
| P11.10        | Present fault output frequency         | -999999.0~999999.0   | Hz   | 0.0           |
| P11.11        | Present fault output current           | -999999.00~999999.00 | A    | 0.00          |
| P11.12        | Present fault bus voltage              | -999999.0~999999.0   | V    | 0.0           |
| P11.13        | Present faulty inverter temperature    | -999999~999999       | ℃    | 0             |
| P11.14        | Present fault X terminal status        | -999999~999999       |      | 0             |
| P11.15        | Present fault Y terminal status        | -999999~999999       |      | 0             |
| P11.16        | Accumulated power-on time              | 0.000~4294967.295    | h    | 0             |
| P11.20        | Output frequency of previous fault     | -999999.0~999999.0   | Hz   | 0.0           |
| P11.21        | output current of Previous fault       | -999999.00~999999.00 | A    | 0.00          |
| P11.22        | Bus voltage of previous fault          | -999999.0~999999.0   | V    | 0.0           |
| P11.23        | Inverter temperature of previous fault | -999999~999999       | ℃    | 0             |
| P11.24        | S-terminal status of previous fault    | -999999~999999       |      | 0             |
| P11.25        | Y terminal status of previous fault    | -999999~999999       |      | 0             |

## H1 series vector control inverter manual V1.0

|        |   |                      |    |      |
|--------|---|----------------------|----|------|
| P11.26 | Accumulated power-on time of the previous fault | 0.000~4294967.295    | h  | 0    |
| P11.30 | Output frequency of the 2rd faults              | -999999.0~999999.0   | Hz | 0.0  |
| P11.31 | The 2rd fault output currents                   | -999999.00~999999.00 | A  | 0.00 |
| P11.32 | Bus voltage of 2rd faults                       | -999999.0~999999.0   | V  | 0.0  |
| P11.33 | Inverter temperature of the 2rd faults          | -999999~999999       | ℃  | 0    |
| P11.34 | S-terminal status of the 2rd faults             | -999999~999999       |    | 0    |
| P11.35 | The 2rd fault Y terminal status                 | -999999~999999       |    | 0    |
| P11.36 | Accumulated power-on time of the 2rd fault      | 0.000~4294967.295    | h  | 0    |

- Function: record fault information

## Group 12 parameters: free parameters

| Parameter NO.         | Parameter Name                                | Setting range          | Unit | Factory value |
|-----------------------|---|------------------------|------|---------------|
| P12.00<br>~<br>P12.19 | Free parameter 1<br>~<br>Free parameters 20   | -999999.000~999999.000 |      | 0.000         |
| P12.90<br>~<br>P12.99 | Free parameter 91<br>~<br>Free parameters 100 | -999999.000~999999.000 |      | 0.000         |

- Function: As an interface or intermediate quantity, expand system functions

Principle explanation:

P12.00 ~ P12.19, P12.90 ~ P12.94, automatically save the current value when power off.

P12.95 ~ P12.99: Set the parameter number. The value of P12.90 ~ P12.94 at power-on is given to the parameter number set in P12.95 ~ P12.99.

Only P12.90 ~ P12.99 parameters are automatically saved after power off.

## Group 13 parameters: function output

| Parameter NO. | Parameter Name | Setting range | Unit | Factory value |
|---------------|----------------|---------------|------|---------------|
|---------------|----------------|---------------|------|---------------|

|            |                   |              |  |   |
|------------|-------------------|--------------|--|---|
| P13.0<br>0 | Comparator output | 0~4294967295 |  | 0 |
| P13.0<br>1 | Logic output      |              |  |   |

Function: Indicate comparator output (see P16.00 ~ P16.35), logic output result (see P16.36 ~ P16.75)

- Comparator output: store all comparator results, bit0 stores comparator 1 results, bit1 stores comparator 2 results, ...
- Logic output: store all logical unit results, bit0 stores logical unit 1 results, bit1 stores logical unit 2 results, ...

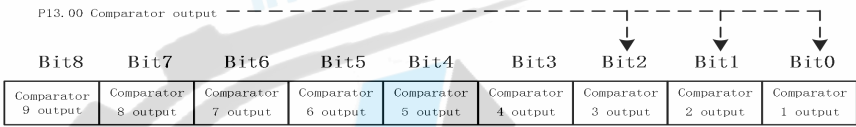

Figure 6-12-1 indicates the output of the comparator

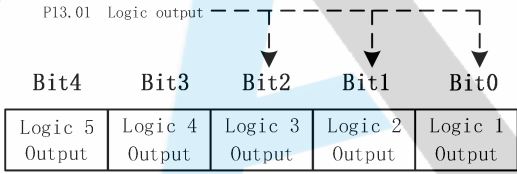

Figure 6-12-2 Indicate the logic output result

| Parameter NO. | Parameter Name                 | Setting range          | Unit | Factory value |
|---------------|--------------------------------|------------------------|------|---------------|
| P13.0<br>2    | Linear transformation result 1 | -999999.000~999999.000 |      | 0.000         |
| P13.0<br>3    | Linear transformation result 2 | -999999.000~999999.000 |      | 0.000         |

Function: Indicate the result of linear transformation (see P17.00 ~ P17.09)

| Parameter NO. | Parameter Name                       | Setting range          | Unit | Factory value |
|---------------|--------------------------------------|------------------------|------|---------------|
| P13.1<br>0    | Single arithmetic operation 1 output | -999999.000~999999.000 |      | 0.000         |
| P13.1<br>1    | Single arithmetic operation 2 output | -999999.000~999999.000 |      | 0.000         |

## H1 series vector control inverter manual V1.0

|            |                                      |                        |       |
|------------|--------------------------------------|------------------------|-------|
| P13.1<br>2 | Single arithmetic operation 3 output | -999999.000~999999.000 | 0.000 |
| P13.1<br>3 | Single arithmetic operation 4 output | -999999.000~999999.000 | 0.000 |
| P13.1<br>4 | Single arithmetic operation 5 output | -999999.000~999999.000 | 0.000 |

- Function: Indicate the output result of single arithmetic operation (P17.16 ~ P17.25)

| Parameter NO. | Parameter Name          | Setting range          | Unit | Factory value |
|---------------|-------------------------|------------------------|------|---------------|
| P13.1<br>5    | Math operation 1 output | -999999.000~999999.000 |      | 0.000         |
| P13.1<br>6    | Math operation 2 output | -999999.000~999999.000 |      | 0.000         |
| P13.1<br>7    | Math operation 3 output | -999999.000~999999.000 |      | 0.000         |
| P13.1<br>8    | Math operation 4 output | -999999.000~999999.000 |      | 0.000         |

- Function: Indicate the output result of mathematical operation (see P17.26 ~ P17.45)

| Parameter NO. | Parameter Name      | Setting range | Unit | Factory value |
|---------------|---------------------|---------------|------|---------------|
| P13.4<br>0    | Comparator 1 output | 0~1           |      | 0             |
| P13.4<br>1    | Comparator 2 output | 0~1           |      | 0             |
| P13.4<br>2    | Comparator 3 output | 0~1           |      | 0             |
| P13.4<br>3    | Comparator 4 output | 0~1           |      | 0             |
| P13.4<br>4    | Comparator 5 output | 0~1           |      | 0             |
| P13.4<br>5    | Comparator 6 output | 0~1           |      | 0             |
| P13.4<br>6    | Comparator 7 output | 0~1           |      | 0             |

## H1 series vector control inverter manual V1.0

|        |                     |     |  |   |
|--------|---------------------|-----|--|---|
| P13.47 | Comparator 8 output | 0~1 |  | 0 |
| P13.48 | Comparator 9 output | 0~1 |  | 0 |

- Function: indicate the bit corresponding to the output of a single comparator (see P16.00 ~ P16.35)

| Parameter NO. | Parameter Name | Setting range | Unit | Factory value |
|---------------|----------------|---------------|------|---------------|
| P13.50        | Logic 1 output | 0~1           |      | 0             |
| P13.51        | Logic 2 output | 0~1           |      | 0             |
| P13.52        | Logic 3 output | 0~1           |      | 0             |
| P13.53        | Logic 4 output | 0~1           |      | 0             |
| P13.54        | Logic 5 output | 0~1           |      | 0             |

- Function: Indicate the bit corresponding to the output of a single logic unit (see P16.36 ~ P16.75)

| Parameter NO. | Parameter Name                | Setting range | Unit | Factory value |
|---------------|-------------------------------|---------------|------|---------------|
| P13.60        | currently counting of Timer 1 | 0~4294967295  |      | 0             |
| P13.61        | Timer 1 current value         | 0~65535       |      | 0             |
| P13.62        | Timer 1 current stage         | 0~16          |      | 0             |
| P13.63        | Timer 2 is currently counting | 0~4294967295  |      | 0             |
| P13.64        | Timer 2 current value         | 0~65535       |      | 0             |
| P13.65        | Timer 2 current stage         | 0~16          |      | 0             |

- Function: indicate the timer result (see P18.00 ~ P18.39)

Current timer value: The timer counts, the count value can be suspended or cleared.

Current state of timer: indicates the state of the timer stage, bit0 corresponds to stage 1, bit1 corresponds to stage 2, ...

Timer current stage: indicates the current stage of the timer.

### Group 14 parameters: encoder

| Parameter NO. | Parameter Name       | Setting range              | Unit | Factory value |
|---------------|----------------------|----------------------------|------|---------------|
| P14.01        | Encoder 1 resolution | 1~2 <sup>31</sup>          |      | 1024          |
| P14.02        | Encoder 1 direction  | 0: forward;<br>1: reversed |      | 0             |

- Function: Set encoder parameters

### Group 16 parameters: logic unit

| Parameter NO. | Parameter Name                              | Setting range                                       | Unit | Factory value |
|---------------|---|---|------|---------------|
| P16.00        | Comparator 1 input parameter selection      | 0~65535   |      | 0             |
| P16.01        | Comparator 1 comparison parameter selection | 0~65535   |      | 0             |
| P16.02        | Comparator 1 configuration                  | 0:>;<br>1:<;<br>2:≥;<br>3:≤;<br>4:=;<br>5:≈;<br>6:≠ |      | 0             |
| P16.03        | Comparator 2 delay time                     | 0.000~600.000                                       |      | 0.000         |
| P16.04        | Comparator 2 input parameter selection      | 0~65535   |      | 0             |
| P16.05        | Comparator 2 comparison parameter selection | 0~65535   |      | 0             |
| P16.06        | Comparator 2 configuration                  | 0:>;<br>1:<;<br>2:≥;<br>3:≤;<br>4:=;<br>5:≈;<br>6:≠ |      | 0             |
| P16.07        | Comparator 2 delay time                     | 0.000~600.000                                       |      | 0.000         |
| P16.08        | Comparator 3 input parameter selection      | 0~65535   |      | 0             |

# H1 series vector control inverter manual V1.0

|        |   |   |  |       |
|--------|---|---|--|-------|
| P16.09 | Comparator 3 comparison parameter selection | 0~65535   |  | 0     |
| P16.10 | Comparator 3 configuration                  | 0:>;<br>1:<;<br>2:≥;<br>3:≤;<br>4:=;<br>5:≈;<br>6:≠ |  | 0     |
| P16.11 | Comparator 3 delay time                     | 0.000~600.000                                       |  | 0.000 |
| P16.12 | Comparator 4 input parameter selection      | 0~65535   |  | 0     |
| P16.13 | Comparator 4 comparison parameter selection | 0~65535   |  | 0     |
| P16.14 | Comparator 4 configuration                  | 0:>;<br>1:<;<br>2:≥;<br>3:≤;<br>4:=;<br>5:≈;<br>6:≠ |  | 0     |
| P16.15 | Comparator 4 delay time                     | 0.000~600.000                                       |  | 0.000 |
| P16.16 | Comparator 5 input parameter selection      | 0~65535   |  | 0     |
| P16.17 | Comparator 5 configuration                  | 0~65535   |  | 0     |
| P16.18 | Comparator 5 delay time                     | 0:>;<br>1:<;<br>2:≥;<br>3:≤;<br>4:=;<br>5:≈;<br>6:≠ |  | 0     |
| P16.19 | Comparator 6 input parameter selection      | 0.000~600.000                                       |  | 0.000 |
| P16.20 | Comparator 6 comparison parameter selection | 0~65535   |  | 0     |
| P16.21 | Comparator 6 configuration                  | 0~65535   |  | 0     |
| P16.22 | Comparator 6 delay time                     | 0:>;<br>1:<;<br>2:≥;<br>3:≤;<br>4:=;<br>5:≈;<br>6:≠ |  | 0     |
| P16.23 | Comparator 7 input parameter selection      | 0.000~600.000                                       |  | 0.000 |

## H1 series vector control inverter manual V1.0

|        |   |   |  |       |
|--------|---|---|--|-------|
| P16.24 | Comparator 7 comparison parameter selection | 0~65535   |  | 0     |
| P16.25 | Comparator 5 configuration                  | 0~65535   |  | 0     |
| P16.26 | Comparator 7 configuration                  | 0:>;<br>1:<;<br>2:≥;<br>3:≤;<br>4:=;<br>5:≈;<br>6:≠ |  | 0     |
| P16.27 | Comparator 7 delay time                     | 0.000~600.000                                       |  | 0.000 |
| P16.28 | Comparator 8 input parameter selection      | 0~65535   |  | 0     |
| P16.29 | Comparator 8 comparison parameter selection | 0~65535   |  | 0     |
| P16.30 | Comparator 8 configuration                  | 0:>;<br>1:<;<br>2:≥;<br>3:≤;<br>4:=;<br>5:≈;<br>6:≠ |  | 0     |
| P16.31 | Comparator 8 delay time                     | 0.000~600.000                                       |  | 0.000 |
| P16.32 | Comparator 9 input parameter selection      | 0~65535   |  | 0     |
| P16.33 | Comparator 9 comparison parameter selection | 0~65535   |  | 0     |
| P16.34 | Comparator 9 configuration                  | 0:>;<br>1:<;<br>2:≥;<br>3:≤;<br>4:=;<br>5:≈;<br>6:≠ |  | 0     |
| P16.35 | Comparator 9 delay time                     | 0.000~600.000                                       |  | 0.000 |

- Function: Set comparison operation

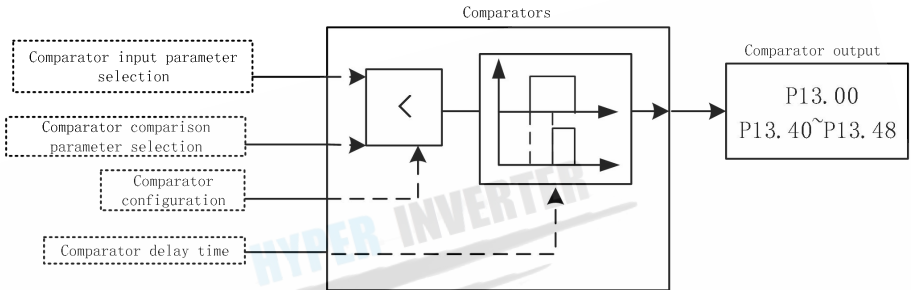

Figure 6-14-1 Comparators

Comparator input parameter selection: this setting is the address. The address is the selected parameter number, and the actual value is determined by the current value of the selected parameter number.

Comparator comparison parameter selection: this setting is the address. The address is the selected parameter number, and the actual value is determined by the current value of the selected parameter number.

Comparator configuration: select the comparison relationship.

Comparator delay time: After the delay time is reached, the comparator result is output.

| Parameter NO. | Parameter Name                     | Setting range  | Unit | Factory value |
|---------------|------------------------------------|--|------|---------------|
| P16.36        | Logic unit 1 parameter selection 1 | 0~65535  |      | 0             |
| P16.37        | Logic unit 1 input bit selection 1 | 0~32   |      | 0             |
| P16.38        | Logic unit 2 parameter selection 2 | 0~65535  |      | 0             |
| P16.39        | Logic unit 2 input bit selection 2 | 0~32   |      | 0             |
| P16.40        | Logic unit 3 parameter selection 3 | 0~65535  |      | 0             |
| P16.41        | Logic unit 3 input bit selection 3 | 0~32   |      | 0             |
| P16.42        | Logical unit configuration 1       | 0: No effect;<br>1: with;<br>2: OR;<br>3: NAND;<br>4: NOR;<br>5: XOR |      | 0             |

|            |                                       |   |  |  |   |
|------------|---------------------------------------|---|--|--|---|
| P16.4<br>3 | Logical unit<br>configuration 2       | 1 | 0: No effect;<br>1: with;<br>2: OR;<br>3: NAND;<br>4: NOR;<br>5: XOR |  | 0 |
| P16.4<br>4 | Logic unit<br>parameter selection 1   | 2 | 0~65535  |  | 0 |
| P16.4<br>5 | Logic unit 2 input bit<br>selection 1 | 2 | 0~32   |  | 0 |
| P16.4<br>6 | Logic unit<br>parameter selection 2   | 2 | 0~65535  |  | 0 |
| P16.4<br>7 | Logic unit 2 input bit<br>selection 2 | 2 | 0~32   |  | 0 |
| P16.4<br>8 | Logic unit<br>parameter selection 3   | 2 | 0~65535  |  | 0 |
| P16.4<br>9 | Logic unit 2 input bit<br>selection 3 | 2 | 0~32   |  | 0 |
| P16.5<br>0 | Logical unit<br>configuration 1       | 2 | 0: No effect;<br>1: with;<br>2: OR;<br>3: NAND;<br>4: NOR;<br>5: XOR |  | 0 |
| P16.5<br>1 | Logical unit<br>configuration 2       | 2 | 0: No effect;<br>1: with;<br>2: OR;<br>3: NAND;<br>4: NOR;<br>5: XOR |  | 0 |

- Function: Set logic function

- 
- Logic unit parameter selection: this setting is the address. The address is the selected parameter number, and the actual value is determined by the current value of the selected parameter number.
  - Logic unit input bit selection: select the bit selection of logic operation parameters, 0 means bit0, 1 means bit1 ...
  - Logic unit configuration 1: configure logical operation of logic unit parameters.

# H1 series vector control inverter manual V1.0

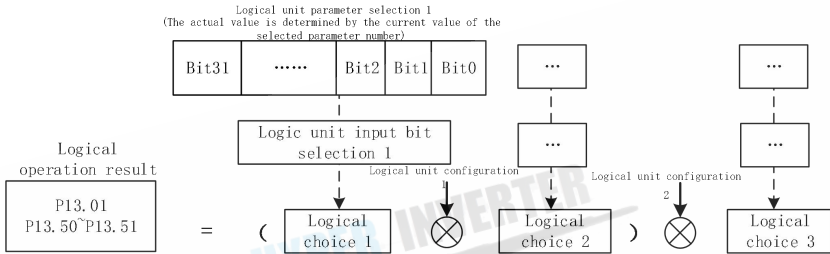

Figure 6-14-2 logic operation

| Parameter NO. | Parameter Name                    | Setting range | Unit | Factory value |
|---------------|-----------------------------------|---------------|------|---------------|
| P16.76        | Selector 1 parameter source       | 0~65535       |      | 0             |
| P16.77        | Selector 1 setting                | 0~16          |      | 0             |
| P16.78        | Selector 1 destination parameters | 0~65535       |      | 0             |
| P16.79        | Selector 2 parameter source       | 0~65535       |      | 0             |
| P16.80        | Selector 2 setting                | 0~16          |      | 0             |
| P16.81        | Selector 2 destination parameters | 0~65535       |      | 0             |
| P16.82        | Selector 3 parameter source       | 0~65535       |      | 0             |
| P16.83        | Selector 3 setting                | 0~16          |      | 0             |
| P16.84        | Selector 3 destination parameters | 0~65535       |      | 0             |
| P16.85        | Selector 4 parameter source       | 0~65535       |      | 0             |
| P16.86        | Selector 4 setting                | 0~16          |      | 0             |
| P16.87        | Selector 4 destination parameters | 0~65535       |      | 0             |
| P16.88        | Selector 5 parameter source       | 0~65535       |      | 0             |
| P16.89        | Selector 5 setting                | 0~16          |      | 0             |
| P16.90        | Selector 5 destination parameters | 0~65535       |      | 0             |
| P16.91        | Selector 6 parameter source       | 0~65535       |      | 0             |

|        |                                   |         |  |   |
|--------|-----------------------------------|---------|--|---|
| P16.92 | Selector 6 setting                | 0~16    |  | 0 |
| P16.93 | Selector 6 destination parameters | 0~65535 |  | 0 |
| P16.94 | Selector 7 parameter source       | 0~65535 |  | 0 |
| P16.95 | Selector 7 setting                | 0~16    |  | 0 |
| P16.96 | Selector 7 destination parameters | 0~65535 |  | 0 |
| P16.97 | Selector 8 parameter source       | 0~65535 |  | 0 |
| P16.98 | Selector 8 setting                | 0~16    |  | 0 |
| P16.99 | Selector 8 destination parameters | 0~65535 |  | 0 |

- Function: selector setting

**Principle explanation:**

As shown in Figure 6-15-3, select one of the 16 consecutive addresses starting with the source of the selector parameter, and pass the current value of this address to the destination parameter of the selector.

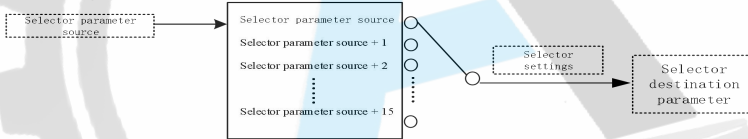

Figure 6-14-3 Selector

For example: P16.76 = 250, P16.78 = 270

When P16.77 = 0, the data of parameter P2.50 is transferred to P2.70;

When P16.77 = 1, the data of parameter P2.51 is transferred to P2.70;

When P16.77 = 2, the data of parameter P2.52 is passed to P2.70;

...

When P16.77 = 13, the data of parameter P2.63 is transferred to P2.70;

When P16.77 = 14, the data of parameter P2.64 is passed to P2.70;

When P16.77 = 15, the data of parameter P2.65 is transferred to P2.70.

**Group 17 parameters: mathematical operations**

| Parameter NO. | Parameter Name                           | Setting range | Unit | Factory value |
|---------------|--|---------------|------|---------------|
| P17.00        | Linear transformation 1 parameter source | 0~65535       |      | 0             |

|            |   |   |                        |  |              |
|------------|---|---|------------------------|--|--------------|
| P17.0<br>1 | Linear transformation<br>X1               | 1 | -999999.000~999999.000 |  | 0.000        |
| P17.0<br>2 | Linear transformation<br>X2               | 1 | -999999.000~999999.000 |  | 50.000       |
| P17.0<br>3 | Linear transformation<br>Y1               | 1 | -999999.000~999999.000 |  | 0.000        |
| P17.0<br>4 | Linear transformation<br>Y2               | 1 | -999999.000~999999.000 |  | 1500.0<br>00 |
| P17.0<br>5 | Linear transformation<br>parameter source | 2 | 0~65535                |  | 0            |
| P17.0<br>6 | Linear transformation<br>X1               | 2 | -999999.000~999999.000 |  | 0.000        |
| P17.0<br>7 | Linear transformation<br>X2               | 2 | -999999.000~999999.000 |  | 0.000        |
| P17.0<br>8 | Linear transformation<br>Y1               | 2 | -999999.000~999999.000 |  | 0.000        |
| P17.0<br>9 | Linear transformation<br>Y2               | 2 | -999999.000~999999.000 |  | 0.000        |

- Function: Set linear transformation operation

**Principle explanation:**

As shown in Figure 6-15-1, the source parameter of the linear transformation parameter is set, and the current value of the reference parameter is used as the x input. Linear relationship setting (modify parameters P17.01-17.04 or parameters P17.05-P17.09).

Example: Different output frequencies correspond to different speeds (0 ~ 50Hz corresponds to 0 ~ 1500rpm), the setting parameters are as follows:

P17.00 = 1021 (source of linear transformation 1 parameter is output frequency)

P17.01 = 0 (linear transformation 1 X1 is 0)

P17.02 = 50 (linear transformation 1 X2 is 50)

P17.03 = 0 (linear transformation 1 Y1 is 0)

P17.04 = 1500 (linear transformation 1 Y2 is 1500)

P13.02 = Linear transformation 1 result

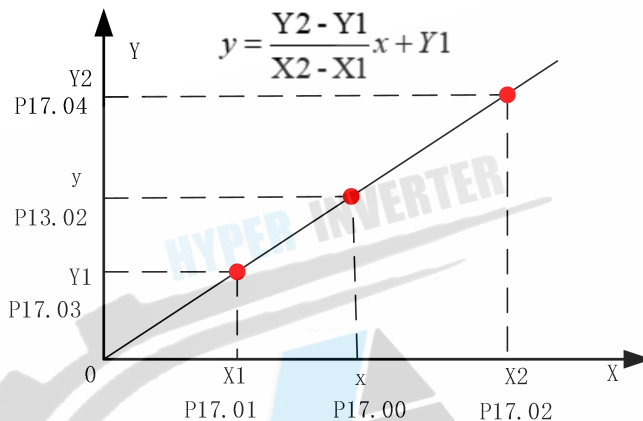

Figure 6-15-1 Linear transformation

| Parameter NO. | Parameter Name                                | Setting range  | Unit | Factor y value |
|---------------|---|--|------|----------------|
| P17.16        | Single arithmetic operation parameter source  | 1 0~65535  |      | 0              |
| P17.17        | Single arithmetic operation operation setting | 1 0:ABS;<br>1:Sqrt;<br>2:Sin;<br>3:Cos;<br>4:power2;<br>5:Power3<br>6: random number |      | 0              |
| P17.18        | Single arithmetic operation parameter source  | 2 0~65535  |      | 0              |
| P17.19        | Single arithmetic operation operation setting | 2 0:ABS;<br>1:Sqrt;<br>2:Sin;<br>3:Cos;<br>4:power2;<br>5:Power3<br>6: random number |      | 0              |

# H1 series vector control inverter manual V1.0

|            |   |   |  |  |   |
|------------|---|---|--|--|---|
| P17.2<br>0 | Single arithmetic operation parameter source  | 3 | 0~65535  |  | 0 |
| P17.2<br>1 | Single arithmetic operation operation setting | 3 | 0:ABS;<br>1:Sqrt;<br>2:Sin;<br>3:Cos;<br>4:power2;<br>5:Power3<br>6: random number |  | 0 |
| P17.2<br>2 | Single arithmetic operation parameter source  | 4 | 0~65535  |  | 0 |
| P17.2<br>3 | Single arithmetic operation operation setting | 4 | 0:ABS;<br>1:Sqrt;<br>2:Sin;<br>3:Cos;<br>4:power2;<br>5:Power3<br>6: random number |  | 0 |
| P17.2<br>4 | Single arithmetic operation parameter source  | 5 | 0~65535  |  | 0 |
| P17.2<br>5 | Single arithmetic operation operation setting | 5 | 0:ABS;<br>1:Sqrt;<br>2:Sin;<br>3:Cos;<br>4:power2;<br>5:Power3<br>6: random number |  | 0 |

- Function: Set single arithmetic operation
- For example: P17.16 = 1200, P17.17 = 4, when P12.00 = 9.000, P13.10 = 81.000

| Parameter NO. | Parameter Name                            | Setting range | Unit | Factory value |
|---------------|---|---------------|------|---------------|
| P17.2<br>6    | Mathematical operation Parameter source 1 | 1<br>0~65535  |      | 0             |

# H1 series vector control inverter manual V1.0

|            |   |  |  |   |
|------------|---|--|--|---|
| P17.2<br>7 | Mathematical operation<br>Parameter<br>source 2 | 1<br>0~65535   |  | 0 |
| P17.2<br>8 | Mathematical operation<br>Parameter<br>source 3 | 1<br>0~65535   |  | 0 |
| P17.2<br>9 | Math operation<br>1 Operation<br>setting 1      | 0:No effect;<br>1:+;<br>2:-;<br>3:*;<br>4:/;<br>5:MAX;<br>6:Min;<br>7:Mean |  | 0 |
| P17.3<br>0 | Math operation<br>1 Operation<br>setting 2      | 0:No effect;<br>1:+;<br>2:-;<br>3:*;<br>4:/;<br>5:MAX;<br>6:Min;<br>7:Mean |  | 0 |
| P17.3<br>1 | Mathematical operation<br>Parameter<br>source 1 | 2<br>0~65535   |  | 0 |
| P17.3<br>2 | Mathematical operation<br>Parameter<br>source 2 | 2<br>0~65535   |  | 0 |
| P17.3<br>3 | Mathematical operation<br>Parameter<br>source 3 | 2<br>0~65535   |  | 0 |
| P17.3<br>4 | Math operation<br>2 Operation<br>setting 1      | 0:No effect<br>1:+;<br>2:-;<br>3:*;<br>4:/;<br>5:MAX;<br>6:Min;<br>7:Mean  |  | 0 |

# H1 series vector control inverter manual V1.0

|            |  |   |  |   |
|------------|--|---|--|---|
| P17.3<br>5 | Math operation<br>2 Operation<br>setting 2         | 0:No effect;<br>1:+;<br>2:- ;<br>3:*;<br>4:/;<br>5:MAX;<br>6:Min;<br>7:Mean |  | 0 |
| P17.3<br>6 | Mathematical<br>operation<br>Parameter<br>source 1 | 0~65535   |  | 0 |
| P17.3<br>7 | Mathematical<br>operation<br>Parameter<br>source 2 | 0~65535   |  | 0 |
| P17.3<br>8 | Mathematical<br>operation<br>Parameter<br>source 3 | 0~65535   |  | 0 |
| P17.3<br>9 | Math operation<br>3 Operation<br>setting 1         | 0:No effect;<br>1:+;<br>2:- ;<br>3:*;<br>4:/;<br>5:MAX;<br>6:Min;<br>7:Mean |  | 0 |
| P17.4<br>0 | Math operation<br>3 Operation<br>setting 2         | 0:No effect;<br>1:+;<br>2:- ;<br>3:*;<br>4:/;<br>5:MAX;<br>6:Min;<br>7:Mean |  | 0 |
| P17.4<br>1 | Mathematical<br>operation<br>Parameter<br>source 1 | 0~65535   |  | 0 |
| P17.4<br>2 | Mathematical<br>operation<br>Parameter<br>source 2 | 0~65535   |  | 0 |
| P17.4<br>3 | Mathematical<br>operation<br>Parameter<br>source 3 | 0~65535   |  | 0 |

|            |  |  |   |
|------------|--|--|---|
| P17.4<br>4 | Math operation<br>4 Operation<br>setting 1 | 0:No effect;<br>1:+;<br>2:-;<br>3:*;<br>4:/;<br>5:MAX;<br>6:Min;<br>7:Mean | 0 |
| P17.4<br>5 | Math operation<br>4 Operation<br>setting 2 | 0:No effect;<br>1:+;<br>2:-;<br>3:*;<br>4:/;<br>5:MAX;<br>6:Min;<br>7:Mean | 0 |

- Function: Set up math operation

- Source of mathematical operation parameters: this setting is the address. The address is the selected parameter number, and the actual value is determined by the current value of the selected parameter number.
- Math operation setting: set math operation.

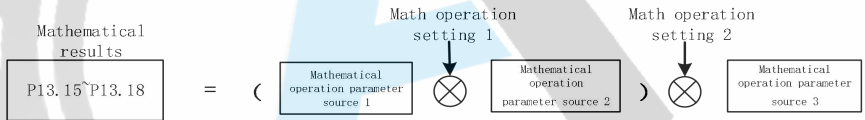

Figure 6-15-2 computation

For example: P17.26 = 1201, P17.27 = 1202, P17.28 = 1203, P17.29 = 1, P17.30 = 3  
 When P12.01 = 2.000, P12.02 = 3.000, P12.03 = 5.000, the calculation result P13.15 = (2.000 + 3.000) \* 5.000 = 25.000

### Group 18 parameters: timing control

| Parameter NO. | Parameter Name       | Setting range  | Unit | Factory value |
|---------------|----------------------|--|------|---------------|
| P18.00        | Timer 1 clock source | 0:1mS;<br>1:10mS;<br>2:100mS;<br>3:1S;<br>200~3799:Address |      | 0             |

# H1 series vector control inverter manual V1.0

|        |                          |  |    |
|--------|--------------------------|--|----|
| P18.01 | Timer 1 working mode     | 0: stop at the end of a single run;<br>1 ~ 16: Set the start of the next cycle       | 0  |
| P18.02 | Timer 1 control commands | Bit0: enable;<br>Bit1: Start counting;<br>Bit2: pause counting;<br>Bit3: Clear count | 0  |
| P18.03 | Timer 1 set value        | -1~4294967295  | -1 |
| P18.04 | Timer 1 phase 1 time     | 0~4294967295   | 0  |
| P18.05 | Timer 1 phase 2 time     | 0~4294967295   | 0  |
| P18.06 | Timer 1 phase 3 time     | 0~4294967295   | 0  |
| P18.07 | Timer 1 phase 4 time     | 0~4294967295   | 0  |
| P18.08 | Timer 1 phase 5 time     | 0~4294967295   | 0  |
| P18.09 | Timer 1 phase 6 time     | 0~4294967295   | 0  |
| P18.10 | Timer 1 phase 7 time     | 0~4294967295   | 0  |
| P18.11 | Timer 1 phase 8 time     | 0~4294967295   | 0  |
| P18.12 | Timer 1 phase 9 time     | 0~4294967295   | 0  |
| P18.13 | Timer 1 phase 10 time    | 0~4294967295   | 0  |
| P18.14 | Timer 1 phase 11 time    | 0~4294967295   | 0  |
| P18.15 | Timer 1 phase 12 time    | 0~4294967295   | 0  |
| P18.16 | Timer 1 phase 13 time    | 0~4294967295   | 0  |
| P18.17 | Timer 1 phase 14 time    | 0~4294967295   | 0  |
| P18.18 | Timer 1 phase 15 time    | 0~4294967295   | 0  |
| P18.19 | Timer 1 phase 16 time    | 0~4294967295   | 0  |
| P18.20 | Timer 1 clock source     | 0:1mS;<br>1:10mS;<br>2:100mS;<br>3:1S;<br>200~3799:Address                           | 0  |

|        |                          |  |    |
|--------|--------------------------|--|----|
| P18.21 | Timer 1 working mode     | 0: stop at the end of a single run;<br>1 ~ 16: Set the start of the next cycle       | 0  |
| P18.22 | Timer 1 control commands | Bit0: enable;<br>Bit1: Start counting;<br>Bit2: pause counting;<br>Bit3: Clear count | 0  |
| P18.23 | Timer 1 set value        | -1~4294967295  | -1 |
| P18.24 | Timer 1 phase 1 time     | 0~4294967295   | 0  |
| P18.25 | Timer 1 phase 2 time     | 0~4294967295   | 0  |
| P18.26 | Timer 1 phase 3 time     | 0~4294967295   | 0  |
| P18.27 | Timer 1 phase 4 time     | 0~4294967295   | 0  |
| P18.28 | Timer 1 phase 5 time     | 0~4294967295   | 0  |
| P18.29 | Timer 1 phase 6 time     | 0~4294967295   | 0  |
| P18.30 | Timer 1 phase 7 time     | 0~4294967295   | 0  |
| P18.31 | Timer 1 phase 8 time     | 0~4294967295   | 0  |
| P18.32 | Timer 1 phase 9 time     | 0~4294967295   | 0  |
| P18.33 | Timer 1 phase 10 time    | 0~4294967295   | 0  |
| P18.34 | Timer 1 phase 11 time    | 0~4294967295   | 0  |
| P18.35 | Timer 1 phase 12 time    | 0~4294967295   | 0  |
| P18.36 | Timer 1 phase 13 time    | 0~4294967295   | 0  |
| P18.37 | Timer 1 phase 14 time    | 0~4294967295   | 0  |
| P18.38 | Timer 1 phase 15 time    | 0~4294967295   | 0  |
| P18.39 | Timer 1 phase 16 time    | 0~4294967295   | 0  |

- Function: Set timer parameters

Timer clock source: Set the timer clock source. Set to 0 ~ 199, this setting is to select a specific time interval, set to 200 ~ 3799, this setting is the address. The address is the selected parameter number, and the actual value is determined by the current value of the

selected parameter number.

Timer working mode: set to 0, it will not cycle after the end of a single run; set to N ( $1 \leq N \leq 16$ ), after the end of a single run, it will automatically start to cycle from N until the timer Stop when you can.

Timer control commands: Bit0: enable; Bit1: start counting, rising edge signal enable; Bit2: pause counting; Bit3: clear counting.

Timer setting value: Set the timer count value.

Timer phase time: set the timer duration of each phase of the timer.

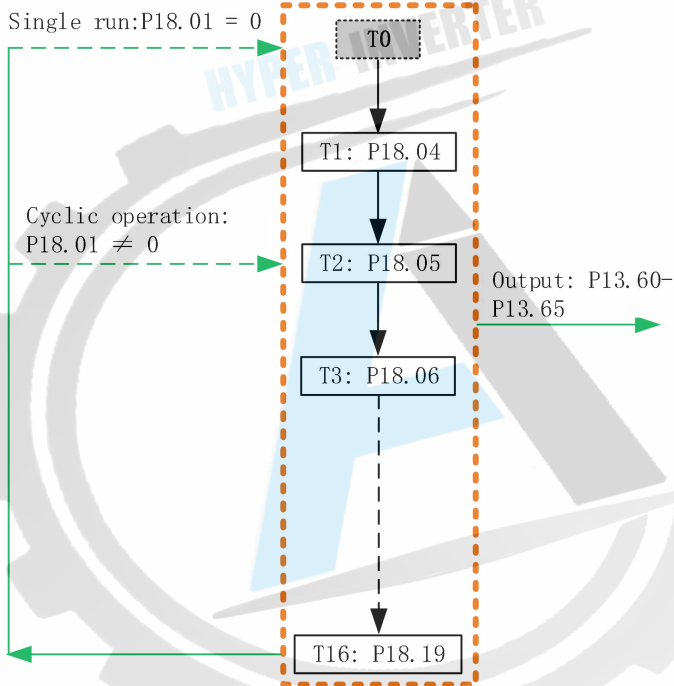

Figure 6-16-1 Timing control



## Chapter 7 Application macro examples

### 7.1 Multi-speed control operation

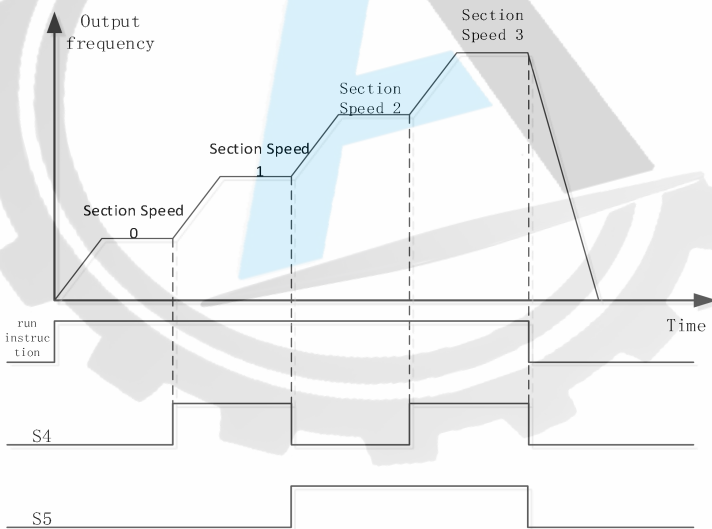

Figure 7-1 Multi-speed selection

Example: The external terminals S4 and S5 control the four-stage speed switching, and the multi-stage speeds are set to 10HZ, 15HZ, 20HZ, 25HZ respectively.

Step 1: Set P1.20 to 31, select multi-stage speed macro;

Step 2: Set P3.00 to 3, select external terminal S1 to control start.

- 6.11 Eight-speed internal control

# H1 series vector control inverter manual V1.0

Example: timing control of eight-stage speed switching, setting multi-stage speeds as 5HZ, 10HZ, 15HZ, 20HZ, 25HZ, 30HZ, 35HZ, 40HZ; external terminal S4 controls multi-stage speed enable, S1 controls motor start.

- Step 1: Set P1.20 to 67, select the internal control eight-stage speed macro;
- Step 2: Set P3.00 to 3, select external terminal S1 to control start.

Example: Timing control of eight-stage speed switching, setting multi-stage speeds as 5HZ, 10HZ, 15HZ, 20HZ, 25HZ, 30HZ, 35HZ, 40HZ; external terminal S4 controls multi-stage speed enable and motor start.

- Step 1: Set P1.20 to 67, select the internal control eight-stage speed macro;
- Step 2: Set P3.00 to 6, select external terminal S4 to control start.

### 6.11 PID control operation

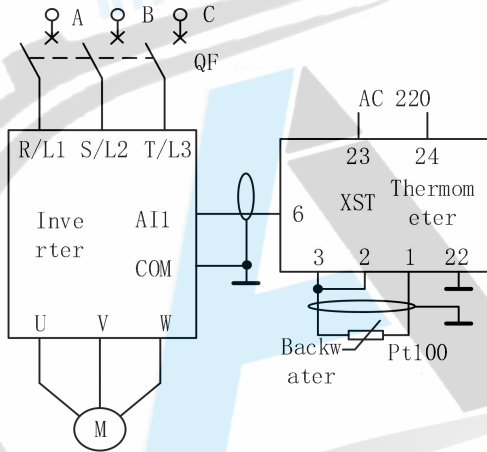

Figure 7-2 PID wiring

Example: PID control operation, set value is multi-step speed, feedback uses AI1, external terminal S1 controls start and stop.

- Step 1: Set P1.20 to 32, select PID macro 1;
- Step 2: Set P1.39 to 0, the command source setting select single command source mode;
- Step 3: Set P3.00 to 3 and select S1 as the source of the start command.

Example: PID control operation, set value is AI2, feedback uses AI1, external terminal S1 controls start and stop.

- Step 1: Set P1.20 to 33, select PID Macro 2;
- Step 2: Set P1.39 to 0, the command source setting select single command source mode;
- Step 3: Set P3.00 to 3 and select S1 as the source of the start command.

Figure 7-3 Application Macro

| No. | Name              | S1 | S2 | S3 | S4 | S5 | Y1 | Y2 | Y3 | AI1 | AI2 | AO1 | AO2 | Key board | Communication |
|-----|-------------------|----|----|----|----|----|----|----|----|-----|-----|-----|-----|-----------|---------------|
| 0~9 | User Macro 1 ~ 10 | x  | x  | x  | x  | x  | x  | x  | x  | x   | x   | x   | x   | x         | x             |

|    |                             |          |                     |                     |                         |                         |         |       |       |                |           |                  |                |                |                              |
|----|-----------------------------|----------|---------------------|---------------------|-------------------------|-------------------------|---------|-------|-------|----------------|-----------|------------------|----------------|----------------|------------------------------|
| 10 | Comprehensive Macro 1       | start up | Reverse start       | JOG                 | Segment speed selection | Segment speed selection | running | Fault | alarm | Set value      | x         | Output frequency | Output current | Start and stop | Start / stop / setting value |
| 11 | Comprehensive Macro 2       | start up | Forward and reverse | JOG                 | Segment speed selection | Segment speed selection | running | Fault | alarm | Set value      | x         | Output frequency | Output current | Start and stop | Start / stop / setting value |
| 12 | Comprehensive Macro 3       | start up | stop                | Forward and reverse | Segment speed selection | Segment speed selection | running | Fault | alarm | Set value      | x         | Output frequency | Output current | Start and stop | Start / stop / setting value |
| 13 | Comprehensive Macro 4       | start up | stop                | JOG                 | x                       | x                       | running | Fault | alarm | Feedback value | Set value | Output frequency | Output current | Start and stop | Start and stop               |
| 20 | 1-line command macro        | start up | x                   | x                   | x                       | x                       | x       | x     | x     | x              | x         | x                | x              | Start and stop | Start / stop / free stop     |
| 21 | 2-line command macro 1      | start up | Reverse start       | x                   | x                       | x                       | x       | x     | x     | x              | x         | x                | x              | Start and stop | Start / stop / free stop     |
| 22 | 2-line command macro 2      | start up | Forward and reverse | x                   | x                       | x                       | x       | x     | x     | x              | x         | x                | x              | Start and stop | Start / stop / free stop     |
| 23 | 3-line command macro 1      | start up | Reverse start       | stop                | x                       | x                       | x       | x     | x     | x              | x         | x                | x              | Start and stop | Start / stop / free stop     |
| 24 | 3-line command macro 2      | start up | Forward and reverse | stop                | x                       | x                       | x       | x     | x     | x              | x         | x                | x              | Start and stop | Start / stop / free stop     |
| 30 | Main and auxiliary settings | x        | x                   | x                   | x                       | x                       | x       | x     | x     | Feedback value | x         | x                | x              | x              | Set value                    |

|    |                         |   |   |   |                         |                         |                       |   |                |           |   |   |   |           |   |   |
|----|-------------------------|---|---|---|-------------------------|-------------------------|-----------------------|---|----------------|-----------|---|---|---|-----------|---|---|
| 31 | Multi-stage speed macro | x | x | x | Segment speed selection | Segment speed selection | x                     | x | x              | x         | x | x | x | x         | x |   |
| 32 | PID Macro 1             | x | x | x | x                       | x                       | x                     | x | Feedback value | x         | x | x | x | x         | x |   |
| 33 | PID Macro 2             | x | x | x | x                       | x                       | x                     | x | Feedback value | Set value | x | x | x | x         | x |   |
| 50 | Speed Start Macro       | x | x | x | x                       | x                       | x                     | x | x              | x         | x | x | x | x         | x |   |
| 51 | DC injection macro      | x | x | x | x                       | x                       | x                     | x | x              | x         | x | x | x | x         | x |   |
| 52 | Free parking macro      | x | x | x | x                       | x                       | x                     | x | x              | x         | x | x | x | x         | x |   |
| 53 | DC brake macro          | x | x | x | x                       | x                       | x                     | x | x              | x         | x | x | x | x         | x |   |
| 54 | Haste Macro             | x | x | x | x                       | x                       | x                     | x | x              | x         | x | x | x | x         | x |   |
| 55 | Jerk macro              | x | x | x | x                       | x                       | x                     | x | x              | x         | x | x | x | x         | x |   |
| 60 | Console switch macro    | x | x | x | Segment speed selection | Segment speed selection | x                     | x | x              | x         | x | x | x | Set value | x |   |
| 61 | Frequency reach macro   | x | x | x | x                       | x                       | Frequency reach       | x | x              | x         | x | x | x | x         | x | x |
| 62 | FDT macro               | x | x | x | x                       | x                       | Frequency reach range | x | x              | x         | x | x | x | x         | x | x |

|    |  |   |   |   |                      |   |  |   |   |   |   |   |   |   |   |
|----|--|---|---|---|----------------------|---|--|---|---|---|---|---|---|---|---|
| 63 | Acceleration and deceleration switching  | x | x | x | x                    | x | x  | x | x | x | x | x | x | x | x |
| 64 | Brake signal macro                       | x | x | x | x                    | x | Frequency too low                              | x | x | x | x | x | x | x | x |
| 65 | Slack gate signal macro                  | x | x | x | x                    | x | Frequency reached and the current is too large | x | x | x | x | x | x | x | x |
| 66 | Break detection macro                    | x | x | x | x                    | x | Frequency reached and current too small        | x | x | x | x | x | x | x | x |
| 67 | Signal loss macro                        | x | x | x | x                    | x | Detection signal is less than the threshold    | x | x | x | x | x | x | x | x |
| 68 | Internal control eight-stage speed macro | x | x | x | Segment speed enable | x | x  | x | x | x | x | x | x | x | x |

## 7.2 Comprehensive Macro 1

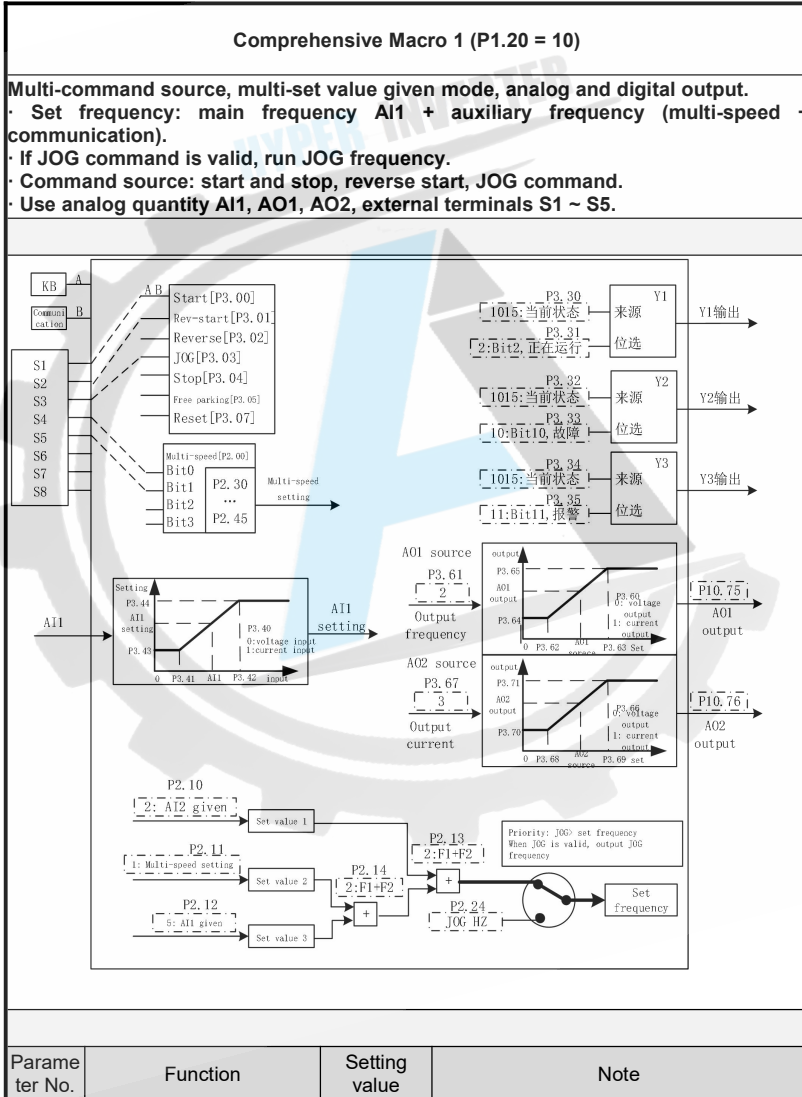

|       |                                   |         |   |
|-------|-----------------------------------|---------|---|
| P2.24 | Jog Frequency                     | 10      | JOG frequency is set to 5HZ                         |
| P2.30 | Multi-speed 0                     | 20      | Auxiliary frequency multi-speed 0 is set to 10HZ    |
| P2.31 | Multi-speed 1                     | 30      | Auxiliary frequency multi-speed 1 is set to 15HZ    |
| P2.32 | Multi-speed 2                     | 40      | Auxiliary frequency multi-speed 2 is set to 20HZ    |
| P2.33 | Multi-speed 3                     | 50      | Auxiliary frequency multi-speed 3 is set to 25HZ    |
| P3.61 | AO1 signal source                 | 2       | Output frequency                                    |
| P3.67 | AO2 signal source                 | 3       | Output current                                      |
|       |                                   |         |   |
| P3.40 | AI1 signal type                   | 0       | AI1 signal type is voltage signal                   |
| P3.41 | AI1 low-end voltage (current)     | 0.050   | 0.050V corresponds to 0HZ                           |
| P3.42 | AI1 high-end voltage (current)    | 10.000  | 10.000V corresponds to 50HZ                         |
| P3.43 | AI1 low-end settings              | 0.000   | AI1 low-end settings                                |
| P3.44 | AI1 high-end settings             | 100.000 | AI1 high-end settings                               |
| P3.60 | AO1 signal type                   | 0       | AO1 signal type is voltage signal                   |
| P3.62 | AO1 low-end settings              | 0.000   | AO1 low-end settings                                |
| P3.63 | AO1 high-end settings             | 50.000  | AO1 high-end settings                               |
| P3.64 | AO1 low-end voltage (current)     | 0.000   | 0.000V corresponds to 0HZ                           |
| P3.65 | AO1 high-end voltage (current)    | 10.000  | 10.000V corresponds to 50HZ                         |
| P3.66 | AO2 signal type                   | 0       | AO2 signal type is voltage signal                   |
| P3.68 | AO2 low-end settings              | 0.000   | AO2 low-end settings                                |
| P3.69 | AO2 high-end settings             | 50.000  | AO2 high-end settings                               |
| P3.70 | AO2 low-end voltage (current)     | 0.000   | 0.000V corresponds to 0HZ                           |
| P3.71 | AO2 high-end voltage (current)    | 10.000  | 10.000V corresponds to 50HZ                         |
|       |                                   |         |   |
| P1.39 | AI1 signal type is voltage signal | 1       | Multi-command source                                |
| P2.00 | 0.050V corresponds to 0HZ         | 11000   | Multi-speed selection for external terminals S4, S5 |
| P2.10 | 10.000V corresponds to 50HZ       | 2       | Set value source 1 select AI1                       |
| P2.11 | AI1 low-end settings              | 1       | Set value source 2 select multi-speed               |

|       |                                   |    |   |
|-------|-----------------------------------|----|---|
| P2.12 | AI1 high-end settings             | 5  | Set value source 3 is communication                                   |
| P2.13 | AO1 signal type is voltage signal | 2  | Set the channel 1 relationship selection to F1 + F2                   |
| P2.14 | AO1 low-end settings              | 2  | Set the channel 2 relationship selection to F1 + F2                   |
| P3.00 | AO1 high-end settings             | 7  | Start command to select keyboard, communication, external terminal S1 |
| P3.01 | 0.000V corresponds to 0HZ         | 8  | Reverse start command is selected as external terminal S2             |
| P3.03 | 10.000V corresponds to 50HZ       | 16 | JOG command is selected as external terminal S3                       |
| P3.30 | AO2 signal type is voltage signal | 3  | Relay 1 comes from the current state is running                       |
| P3.32 | AO2 low-end settings              | 4  | Relay 2 comes from current state fault                                |
| P3.34 | AO2 high-end settings             | 5  | Relay 3 comes from the current state alarm                            |

### 7.3 Comprehensive Macro 2

|  |
|--|
| <b>Comprehensive Macro 2 (P1.20 = 11)</b>  |
| <p><b>Multi-command source, multi-set value given mode, analog and digital output.</b></p> <ul style="list-style-type: none"> <li>· <b>Set frequency:</b> The main frequency AI1 + auxiliary frequency (multi-stage speed + communication) is given.</li> <li>· <b>If JOG command is valid, run JOG frequency.</b></li> <li>· <b>Command source:</b> start and stop, forward and reverse, JOG command.</li> <li>· <b>Use analog quantity AI1, AO1, AO2, external terminals S1 ~ S5.</b></li> </ul> |

# H1 series vector control inverter manual V1.0

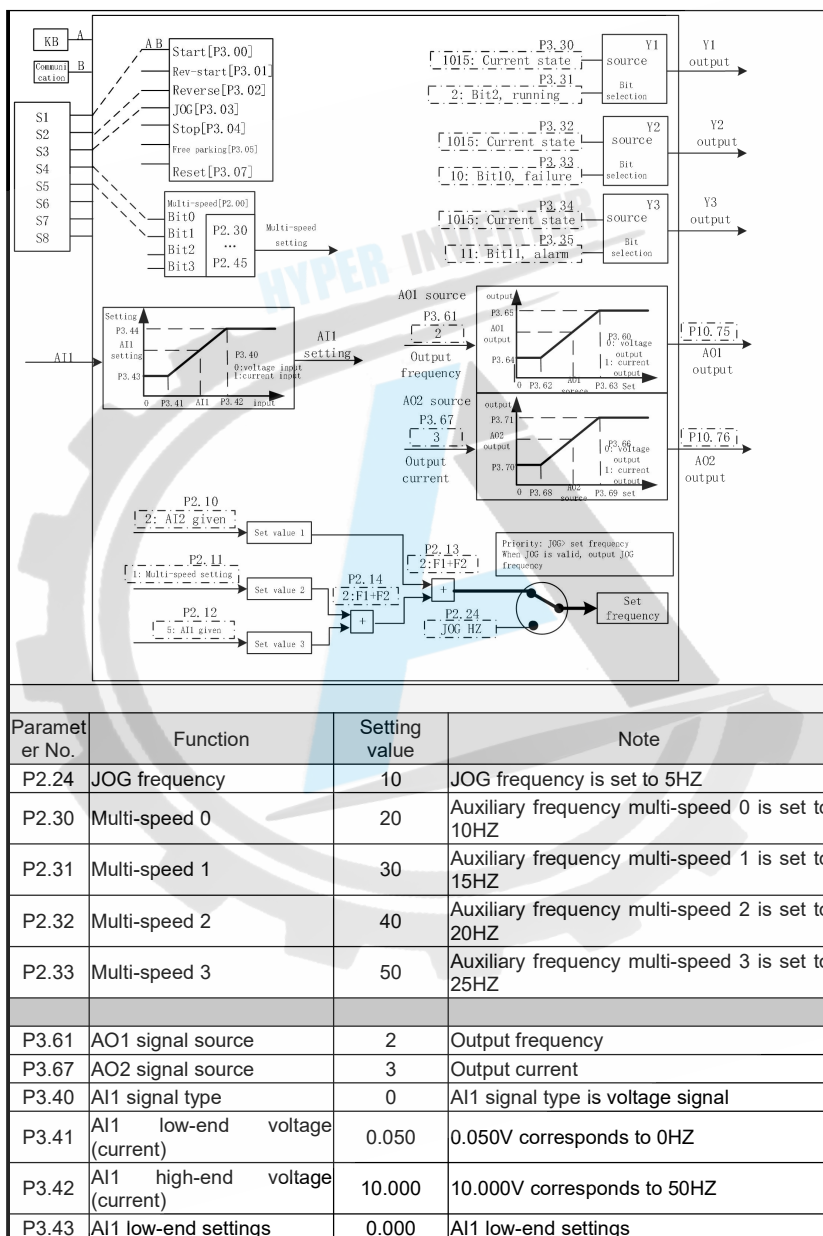

|       |                                      |         |  |
|-------|--------------------------------------|---------|--|
| P3.44 | AI1 high-end settings                | 100.000 | AI1 high-end settings  |
| P3.60 | AO1 signal type                      | 0       | AO1 signal type is voltage signal  |
| P3.62 | AO1 low-end settings                 | 0.000   | AO1 low-end settings   |
| P3.63 | AO1 high-end settings                | 50.000  | AO1 high-end settings  |
| P3.64 | AO1 low-end voltage (current)        | 0.000   | 0.000V corresponds to 0HZ  |
| P3.65 | AO1 high-end voltage (current)       | 10.000  | 10.000V corresponds to 50HZ  |
| P3.66 | AO2 signal type                      | 0       | AO2 signal type is voltage signal  |
| P3.68 | AO2 low-end settings                 | 0.000   | AO2 low-end settings   |
| P3.69 | AO2 high-end settings                | 50.000  | AO2 high-end settings  |
| P3.70 | AO2 low-end voltage (current)        | 0.000   | 0.000V corresponds to 0HZ  |
| P3.71 | AO2 high-end voltage (current)       | 10.000  | 10.000V corresponds to 50HZ  |
|       |                                      |         |  |
| P1.39 | Command format                       | 1       | Multi-command source   |
| P2.00 | Multi-speed source                   | 11000   | Multi-speed selection is S4, S5  |
| P2.10 | Setpoint source 1                    | 2       | Set value source 1 to AI1  |
| P2.11 | Set value source 2                   | 1       | Set value source 2 is multi-speed  |
| P2.12 | Setpoint source 3                    | 5       | Set value source 3 is communication                                      |
| P2.13 | Set channel 1 relationship selection | 2       | Set the channel 1 relationship selection to F1 + F2                      |
| P2.14 | Set channel 2 relationship selection | 2       | Set the channel 2 relationship selection to F1 + F2                      |
| P3.00 | Start command source                 | 7       | Start command selection is keyboard, communication, external terminal S1 |
| P3.02 | Reverse command source               | 8       | Reverse command selection is external terminal S2                        |
| P3.03 | JOG command source                   | 16      | JOG command is selected as external terminal S3                          |
| P3.30 | Y1 terminal source                   | 3       | Relay 1 comes from the current state is running                          |
| P3.32 | Y2 terminal source                   | 4       | Relay 2 comes from current state fault                                   |
| P3.34 | Y3 terminal source                   | 5       | Relay 3 comes from the current state alarm                               |

## 7.4 Comprehensive Macro 3

**Comprehensive Macro 3 (P1.20 = 12)**

**Multi-command source, multi-set value given mode, analog and digital output.**

- Set frequency: The main frequency A11 + auxiliary frequency (multi-stage speed communication) is given.
- Command source: start stop, stop, forward and reverse.
- Use analog quantity A11, AO1, AO2, external terminals S1 ~ S5.

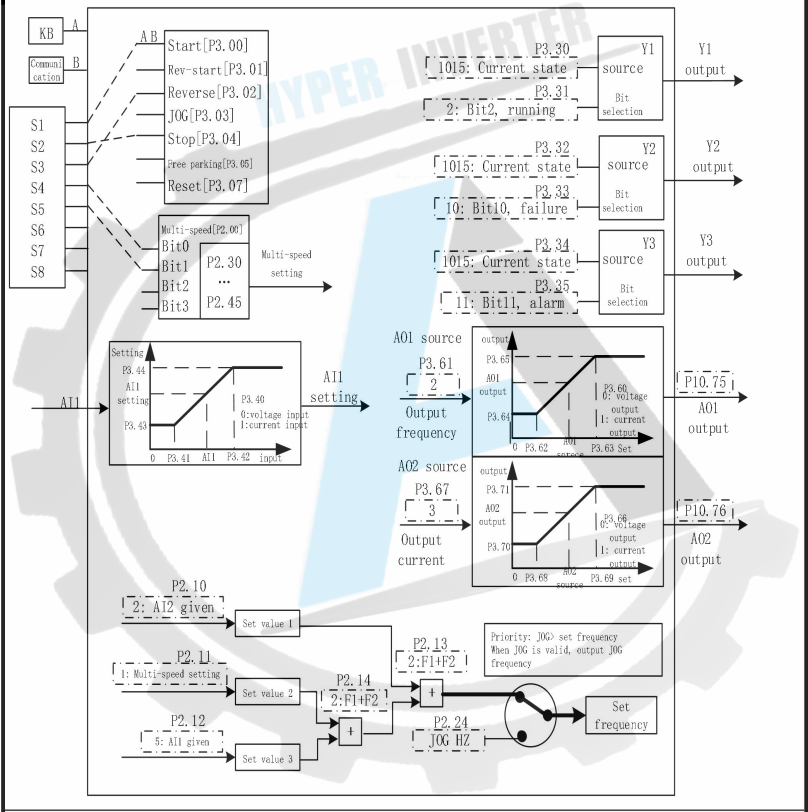

| Parameter No. | Function      | Setting value | Note   |
|---------------|---------------|---------------|--|
| P2.30         | Multi-speed 0 | 20            | Auxiliary frequency multi-speed 0 is set to 10HZ |
| P2.31         | Multi-speed 1 | 30            | Auxiliary frequency multi-speed 1 is set to 15HZ |
| P2.32         | Multi-speed 2 | 40            | Auxiliary frequency multi-speed 2 is set to 20HZ |

## H1 series vector control inverter manual V1.0

|       |                                      |         |   |
|-------|--------------------------------------|---------|---|
| P2.33 | Multi-speed 3                        | 50      | Auxiliary frequency multi-speed 3 is set to 25HZ    |
| P3.61 | AO1 signal source                    | 2       | Output frequency                                    |
| P3.67 | AO2 signal source                    | 3       | Output current                                      |
| P3.40 | AI1 signal type                      | 0       | AI1 signal type defaults to voltage signal          |
| P3.41 | AI1 low-end voltage (current)        | 0.050   | 0.050V corresponds to 0HZ                           |
| P3.42 | AI1 high-end voltage (current)       | 10.000  | 10.000V corresponds to 50HZ                         |
| P3.43 | AI1 low-end settings                 | 0.000   | AI1 low-end settings                                |
| P3.44 | AI1 high-end settings                | 100.000 | AI1 high-end settings                               |
| P3.60 | AO1 signal type                      | 0       | AO1 signal type is voltage signal                   |
| P3.62 | AO1 low-end settings                 | 0.000   | AO1 low-end settings                                |
| P3.63 | AO1 high-end settings                | 50.000  | AO1 high-end settings                               |
| P3.64 | AO1 low-end voltage (current)        | 0.000   | 0.000V corresponds to 0HZ                           |
| P3.65 | AO1 high-end voltage (current)       | 10.000  | 10.000V corresponds to 50HZ                         |
| P3.66 | AO2 signal type                      | 0       | AO2 signal type is voltage signal                   |
| P3.68 | AO2 low-end settings                 | 0.000   | AO2 low-end settings                                |
| P3.69 | AO2 high-end settings                | 50.000  | AO2 high-end settings                               |
| P3.70 | AO2 low-end voltage (current)        | 0.000   | 0.000V corresponds to 0HZ                           |
| P3.71 | AO2 high-end voltage (current)       | 10.000  | 10.000V corresponds to 50HZ                         |
| P1.39 | Command format                       | 1       | Multi-command source                                |
| P2.00 | Multi-speed source                   | 11000   | Multi-speed selection for external terminals S4, S5 |
| P2.10 | Setpoint source 1                    | 2       | Set value source 1 to AI1                           |
| P2.11 | Set value source 2                   | 1       | Set value source 2 is multi-speed                   |
| P2.12 | Setpoint source 3                    | 5       | Set value source 3 is communication                 |
| P2.13 | Set channel 1 relationship selection | 2       | Set the channel 1 relationship selection to F1 + F2 |
| P2.14 | Set channel 2 relationship selection | 2       | Set the channel 2 relationship selection to F1 + F2 |

|       |                        |    |  |
|-------|------------------------|----|--|
| P3.00 | Start command source   | 7  | Start command selection is keyboard, communication, external terminal S1 |
| P3.04 | Source of stop command | 8  | Stop command is selected as external terminal S2                         |
| P3.02 | Reverse command source | 16 | Reverse command selection is external terminal S3                        |
| P3.30 | Y1 terminal source     | 3  | Relay 1 comes from the current state is running                          |
| P3.32 | Y2 terminal source     | 4  | Relay 2 comes from current state fault                                   |
| P3.34 | Y3 terminal source     | 5  | Relay 3 comes from the current state alarm                               |

## 7.5 Comprehensive Macro 4

|  |
|--|
| <b>Comprehensive Macro 4 (P1.20 = 13)</b>  |
| <p><b>Multi-command source, PID main and auxiliary setting value given mode, analog and digital output.</b></p> <ul style="list-style-type: none"> <li>· <b>Set frequency:</b> The main frequency AI2 + auxiliary frequency PID is given. PID setting: multi-step speed, PID feedback: AI1.</li> <li>· <b>If JOG command is valid, run JOG frequency.</b></li> <li>· <b>Command source:</b> start stop, stop, JOG command.</li> <li>· <b>Use analog AI1, AI2, AO1, AO2, external terminals S1 ~ S3.</b></li> </ul> |

# H1 series vector control inverter manual V1.0

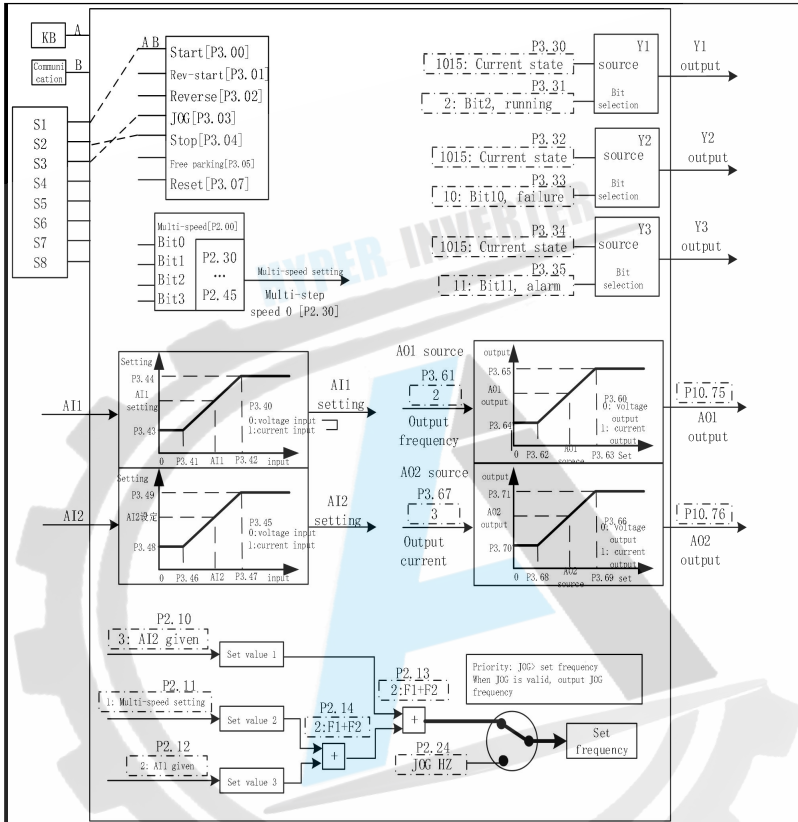

| Parameter No. | Function                      | Setting value | Note                              |
|---------------|-------------------------------|---------------|-----------------------------------|
| P2.24         | JOG frequency                 | 10            | JOG frequency is set to 5HZ       |
| P2.30         | Multi-speed 0                 | 20            | PID setting is set to 10HZ        |
| P3.61         | AO1 signal source             | 2             | Output frequency                  |
| P3.67         | AO2 signal source             | 3             | Output current                    |
| P3.40         | AI1 signal type               | 0             | AI1 signal type is voltage signal |
| P3.41         | AI1 low-end voltage (current) | 0.050         | 0.050V corresponds to 0HZ         |
| P3.42         | AI1 high-end voltage          | 10.000        | 10.000V corresponds to 50HZ       |

## H1 series vector control inverter manual V1.0

|       |                                      |         |  |
|-------|--------------------------------------|---------|--|
|       | (current)                            |         |  |
| P3.43 | AI1 low-end settings                 | 0.000   | AI1 low-end settings   |
| P3.44 | AI1 high-end settings                | 100.000 | AI1 high-end settings  |
| P3.45 | AI2 signal type                      | 0       | AI2 signal type is voltage signal  |
| P3.46 | AI2 low-end voltage (current)        | 0.050   | 0.050V corresponds to 0HZ  |
| P3.47 | AI2 high-end voltage (current)       | 10.000  | 10.000V corresponds to 50HZ  |
| P3.48 | AI2 low-end settings                 | 0.000   | AI2 low-end settings   |
| P3.49 | AI2 high-end settings                | 50.000  | AI2 high-end settings  |
| P3.60 | AO1 signal type                      | 0       | AO1 signal type is voltage signal  |
| P3.62 | AO1 low-end settings                 | 0.000   | AO1 low-end settings   |
| P3.63 | AO1 high-end settings                | 50.000  | AO1 high-end settings  |
| P3.64 | AO1 low-end voltage (current)        | 0.000   | 0.000V corresponds to 0HZ  |
| P3.65 | AO1 high-end voltage (current)       | 10.000  | 10.000V corresponds to 50HZ  |
| P3.66 | AO2 signal type                      | 0       | AO2 signal type is voltage signal  |
| P3.68 | AO2 low-end settings                 | 0.000   | AO2 low-end settings   |
| P3.69 | AO2 high-end settings                | 50.000  | AO2 high-end settings  |
| P3.70 | AO2 low-end voltage (current)        | 0.000   | 0.000V corresponds to 0HZ  |
| P3.71 | AO2 high-end voltage (current)       | 10.000  | 10.000V corresponds to 50HZ  |
|       |                                      |         |  |
| P1.39 | Command format                       | 1       | Multi-command source   |
| P2.00 | Multi-speed source                   | 0       | Multi-speed selection without external terminals                         |
| P2.10 | Setpoint source 1                    | 3       | Set value source 1 to AI2  |
| P2.11 | Set value source 2                   | 1       | Set value source 2 is multi-speed  |
| P2.12 | Setpoint source 3                    | 2       | Set value source 3 to AI1  |
| P2.13 | Set channel 1 relationship selection | 2       | Set the channel 1 relationship selection to F1 + F2                      |
| P2.14 | Set channel 2 relationship selection | 8       | Set the channel 2 relationship selection to PID                          |
| P3.00 | Start command source                 | 7       | Start command selection is keyboard, communication, external terminal S1 |
| P3.04 | Source of stop command               | 8       | Stop command is selected as external terminal S2                         |

|       |                    |    |   |
|-------|--------------------|----|---|
| P3.03 | JOG command source | 16 | JOG command is selected as external terminal S3 |
| P3.30 | Y1 terminal source | 3  | Relay 1 comes from the current state is running |
| P3.32 | Y2 terminal source | 4  | Relay 2 comes from current state fault          |
| P3.34 | Y3 terminal source | 5  | Relay 3 comes from the current state alarm      |

### 1-Line command macro

**1-Line command macro (P1.20=20)**

**S1 controls start and stop.**

- The source of the command includes start and stop and free stop.
- Use external terminal S1.

| Parameter No. | Function               | Setting value | Note   |
|---------------|------------------------|---------------|--|
| P2.91         | Communication commands | 0             | 0 is no command; 1 is start command; 32 is free stop                     |
| P1.39         | Command format         | 1             | Multi-command source   |
| P3.00         | Start command source   | 7             | Start command selection is keyboard, communication, external terminal S1 |
| P3.04         | Source of stop command | 0             | No effect  |

|       |                           |   |   |
|-------|---------------------------|---|---|
| P3.05 | Free parking order source | 2 | Free stop command is selected for communication |
|-------|---------------------------|---|---|

## 2-Line command macro 1

| 2-Line command macro 1 (P1.20=21)   |                              |               |  |
|---|------------------------------|---------------|--|
| <p>S1 controls forward rotation and S2 controls reverse rotation.<br/>                     · Command sources include start and stop, reverse start, and free stop.<br/>                     · Use external terminals S1 ~ S2.</p> |                              |               |  |
|   |                              |               |  |
| Parameter No.   | Function                     | Setting value | Note   |
| P1.39   | Command format               | 1             | Multi-command source   |
| P3.00   | Start command source         | 7             | Start command selection is keyboard, communication, external terminal S1 |
| P3.01   | Reverse start command source | 8             | Reverse start command is selected as external terminal S2                |
| P3.04   | Source of stop command       | 0             | No effect  |
| P3.05   | Free parking order source    | 2             | Free stop command is selected for communication                          |

## 2-Line command macro 2

2-Line command macro 2 (P1.20 = 22)

S1 controls start and stop, S2 controls direction.  
 · The command sources include start and stop, forward and reverse, and free stop.  
 · Use external terminals S1 ~ S2.

| Parameter No. | Function                  | Setting value | Note   |
|---------------|---------------------------|---------------|--|
| P1.39         | Command format            | 1             | Multi-command source   |
| P3.00         | Start command source      | 7             | Start command selection is keyboard, communication, external terminal S1 |
| P3.02         | Reverse command source    | 8             | Reverse command selection is external terminal S2                        |
| P3.04         | Source of stop command    | 0             | No effect  |
| P3.05         | Free parking order source | 2             | Free stop command is selected for communication                          |

### 3-Line command macro 1

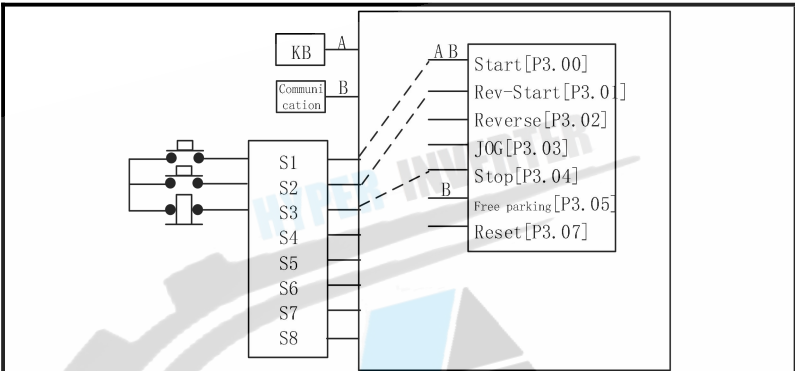

### 3-Line command macro 1

**Three-wire system.**

- The command sources include start, reverse start, stop and free stop.
- Use external terminals S1 ~ S3.

| Parameter No. | Function                     | Setting value | Note   |
|---------------|------------------------------|---------------|--|
| P1.39         | Command format               | 1             | Multi-command source   |
| P3.00         | Start command source         | 7             | Start command selection is keyboard, communication, external terminal S1 |
| P3.01         | Reverse start command source | 8             | Reverse start command is selected as external terminal S2                |
| P3.04         | Source of stop command       | 16            | Stop command is selected as S3 terminal                                  |
| P3.05         | Free parking order source    | 2             | Free stop command is selected for communication                          |
| P3.20         | S1 type                      | 2             | Trigger on rising edge   |
| P3.21         | S2 type                      | 2             | Trigger on rising edge   |
| P3.22         | S3 type                      | 3             | Trigger on falling edge  |

### 3-Line command macro 2

**3-Line command macro 2**

**Three-wire system.**

- The command sources include start and stop, forward and reverse, stop and free stop.
- Use external terminals S1 ~ S3.

| Parameter No. | Function                  | Setting value | Note                      |
|---------------|---------------------------|---------------|---------------------------|
| P1.39         | Command format            | 1             | Command format            |
| P3.00         | Start command source      | 7             | Start command source      |
| P3.02         | Reverse command source    | 8             | Reverse command source    |
| P3.04         | Source of stop command    | 16            | Source of stop command    |
| P3.05         | Free parking order source | 2             | Free parking order source |
| P3.20         | S1 type                   | 2             | S1 type                   |
| P3.22         | S3 type                   | 3             | S3 type                   |

## Main and auxiliary settings

| Main and auxiliary settings (P1.20 = 30)  |                        |               |        |  |
|---|------------------------|---------------|--------|--|
| <p>Various setting values are added and given.</p> <ul style="list-style-type: none"> <li>The set frequency is given by the main frequency AI1 + auxiliary frequency (multi-stage speed + communication).</li> <li>No command source is given.</li> <li>No external terminals are used.</li> </ul>  |                        |               |        |  |
| <p>The diagram illustrates the calculation of the Set frequency. It starts with the AI1 signal, which is processed through a graph (P3.43 to P3.44) to determine the AI1 setting (P3.40). This setting is then multiplied by the Multi-speed 0 setting (P2.10) to produce Set value 1. The Multi-speed setting (P2.11) produces Set value 2, and the Communication given setting (P2.12) produces Set value 3. These three values are summed together to produce the final Set frequency (P2.13).</p> |                        |               |        |  |
| Parameter No.   | Function               | Setting value |        | Note   |
| P2.30   | Multi-speed 0          | 20            |        | Auxiliary frequency multi-speed 0 is set to 10HZ |
| P3.40   | AI1 signal type        | 0             |        | AI1 signal type is voltage signal                |
| P3.41   | AI1 low-end (current)  | voltage       | 0.050  | 0.050V corresponds to 0HZ                        |
| P3.42   | AI1 high-end (current) | voltage       | 10.000 | 10.000V corresponds to 50HZ                      |
| P3.43   | AI1 low-end settings   |               | 0.000  | AI1 low-end settings                             |

|       |                                      |         |   |
|-------|--------------------------------------|---------|---|
| P3.44 | AI1 high-end settings                | 100.000 | AI1 high-end settings                               |
| P2.10 | Setpoint source 1                    | 2       | Set value source 1 to AI1                           |
| P2.11 | Set value source 2                   | 1       | Set value source 2 is multi-speed                   |
| P2.12 | Setpoint source 3                    | 5       | Set value source 3 is communication                 |
| P2.13 | Set channel 1 relationship selection | 2       | Set the channel 1 relationship selection to F1 + F2 |
| P2.14 | Set channel 2 relationship selection | 2       | Set the channel 2 relationship selection to F1 + F2 |
| P2.00 | Multi-speed source                   | 0       | Multi-speed selection without external terminals    |

## Multi-speed macro

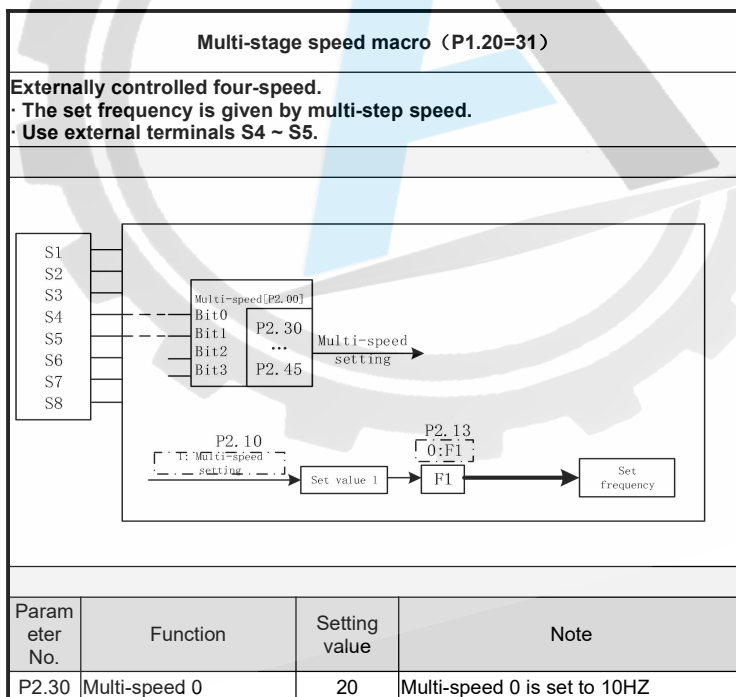

|       |                                    |       |   |
|-------|------------------------------------|-------|---|
| P2.31 | Multi-speed 1                      | 30    | Multi-speed 1 is set to 15HZ                        |
| P2.32 | Multi-speed 2                      | 40    | Multi-speed 2 is set to 20HZ                        |
| P2.33 | Multi-speed 3                      | 50    | Multi-speed 3 is set to 25HZ                        |
|       |                                    |       |   |
| P2.10 | Setpoint source 1                  | 1     | Set value source 1 is multi-speed                   |
| P2.13 | Set channel relationship selection | 0     | Set channel 1 relationship to F1                    |
| P2.00 | Multi-speed source                 | 11000 | Multi-speed selection for external terminals S4, S5 |

## PID Macro 1

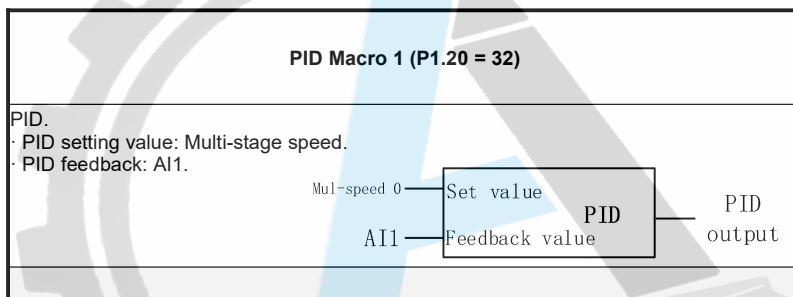

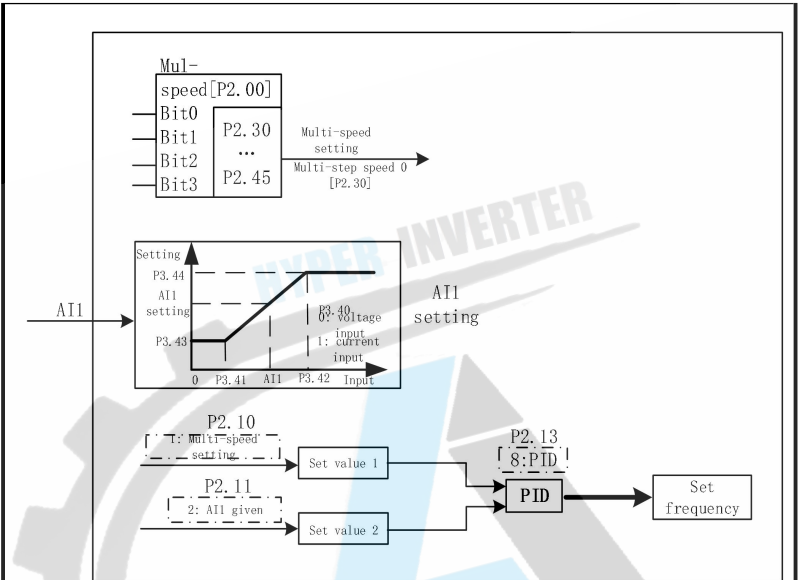

| Parameter No. | Function                             | Setting value | Note   |
|---------------|--------------------------------------|---------------|--|
| P2.30         | Multi-speed 0                        | 20            | PID setting                                      |
| P3.40         | AI1 signal type                      | 0             | AI1 signal type is voltage signal                |
| P3.41         | AI1 low-end voltage (current)        | 0.050         | PID feedback signal lower limit                  |
| P3.42         | AI1 high-end voltage (current)       | 10.000        | PID feedback signal upper limit                  |
| P3.43         | AI1 low-end settings                 | 0.000         | PID feedback value lower limit                   |
| P3.44         | AI1 high-end settings                | 100.000       | PID feedback value upper limit                   |
| P2.10         | Setpoint source 1                    | 1             | Set value source 1 is multi-speed                |
| P2.11         | Set value source 2                   | 2             | Set value source 2 to AI1                        |
| P2.13         | Set channel 1 relationship selection | 8             | Set channel 1 relationship to PID                |
| P2.00         | Multi-speed source                   | 0             | Multi-speed selection without external terminals |

## PID Macro 2

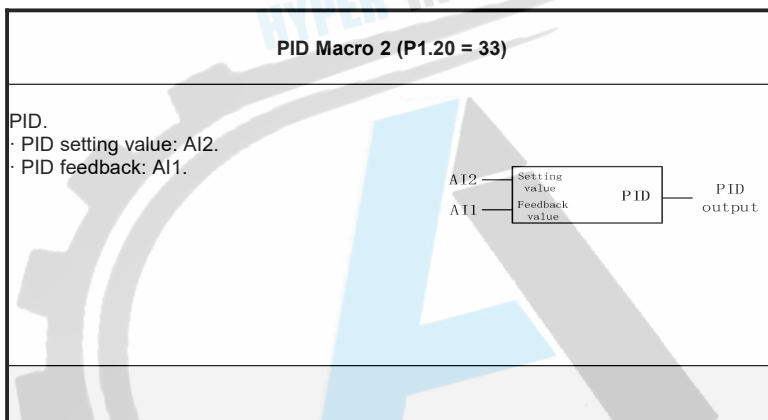

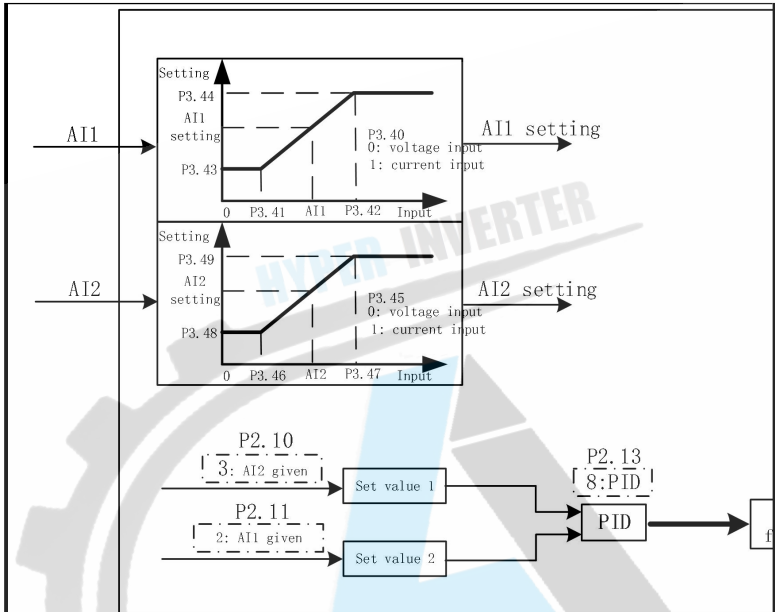

| Parameter No. | Function                       | Setting value | Note                              |
|---------------|--------------------------------|---------------|-----------------------------------|
| P3.40         | AI1 signal type                | 0             | AI1 signal type is voltage signal |
| P3.41         | AI1 low-end voltage (current)  | 0.050         | PID feedback signal lower limit   |
| P3.42         | AI1 high-end voltage (current) | 10.000        | PID feedback signal upper limit   |
| P3.43         | AI1 low-end settings           | 0.000         | PID feedback value lower limit    |
| P3.44         | AI1 high-end settings          | 100.000       | PID feedback value upper limit    |
| P3.45         | AI2 signal type                | 0             | AI2 signal type is voltage signal |

|       |                                      |         |  |
|-------|--------------------------------------|---------|--|
| P3.46 | AI2 low-end voltage (current)        | 0.050   | PID setting signal lower limit                   |
| P3.47 | AI2 high-end voltage (current)       | 10.000  | PID setting signal upper limit                   |
| P3.48 | AI2 low-end settings                 | 0.000   | Lower limit of PID setting                       |
| P3.49 | AI2 high-end settings                | 100.000 | PID setting upper limit                          |
|       |                                      |         |  |
| P2.10 | Setpoint source 1                    | 3       | Set value source 1 to AI2                        |
| P2.11 | Set value source 2                   | 2       | Set value source 2 to AI1                        |
| P2.13 | Set channel relationship selection 1 | 8       | Set channel 1 relationship to PID                |
| P2.00 | Multi-speed source                   | 0       | Multi-speed selection without external terminals |

### Speed Start Macro

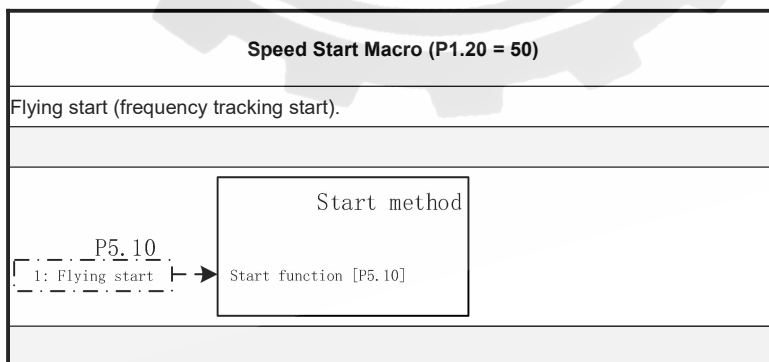

| Parameter No. | Function       | Setting value | Note                                  |
|---------------|----------------|---------------|---------------------------------------|
| P5.10         | Start function | 1             | The start function is the speed start |

### DC injection macro

| DC injection macro (P1.20 = 51) |                |               |                                |
|---------------------------------|----------------|---------------|--------------------------------|
| DC injection starts.            |                |               |                                |
|                                 |                |               |                                |
| Parameter No.                   | Function       | Setting value | Note                           |
| P5.10                           | Start function | 2             | Start function is DC injection |

### Free Parking Macro

| Macro of free parking (P1.20 = 52) |                |               |                                    |
|------------------------------------|----------------|---------------|------------------------------------|
| Free parking.                      |                |               |                                    |
|                                    |                |               |                                    |
| Parameter No.                      | Function       | Setting value | Note                               |
| P5.20                              | Stop function  | 0             | Stop function for free stop        |
| P5.21                              | Stop frequency | 100.000       | Stop frequency is set to 100.000Hz |

## DC braking macro

| DC braking macro (P1.20 = 53)  |                |               |                              |
|--|----------------|---------------|------------------------------|
| DC braking stops.  |                |               |                              |
| <p>The diagram shows a dashed box containing 'P5.20' and '1:DC braking'. An arrow points from this box to a solid box containing 'Stop function [P5.20]'. Above this solid box is another box labeled 'Stop Method'.</p> |                |               |                              |
| Parameter No.  | Function       | Setting value | Note                         |
| P5.20  | Stop function  | 1             | Stop function is DC braking  |
| P5.21  | Stop frequency | 3             | Stop frequency is set to 3Hz |

## Haste Macro

| Rapid acceleration macro (P1.20 = 54) |  |
|---------------------------------------|--|
| Quick Start.                          |  |
|                                       |  |

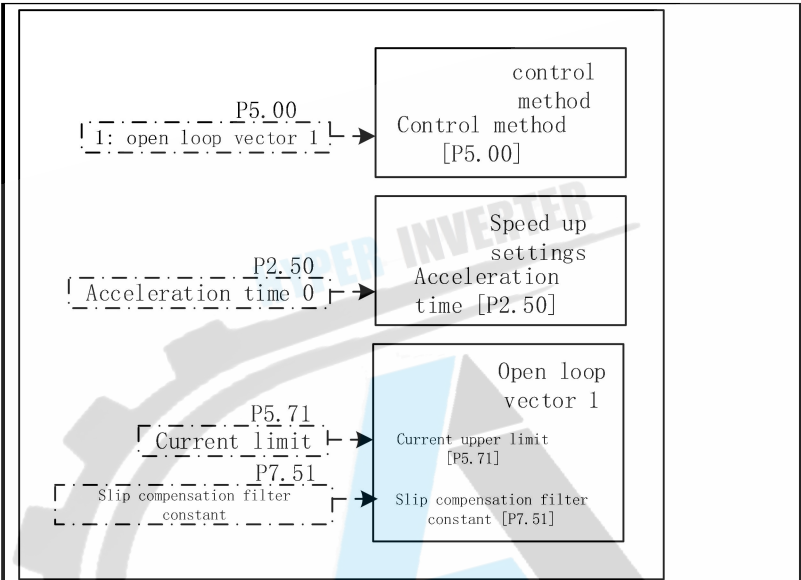

| Parameter No. | Function                          | Setting value | Note  |
|---------------|-----------------------------------|---------------|---|
| P2.50         | Acceleration time 0               | 1             | The acceleration time is set to 1s          |
| P5.00         | control method                    | 1             | Select open loop vector 1                   |
| P5.71         | Current limit                     | 160           | The current limit is set to 160%            |
| P7.51         | Slip compensation filter constant | 150           | The slip compensation filter is set to 150% |

### Sudden Deceleration Macro

|  |
|--|
| <b>Rapid deceleration macro (P1.20 = 55)</b> |
| Stop quickly.                                |

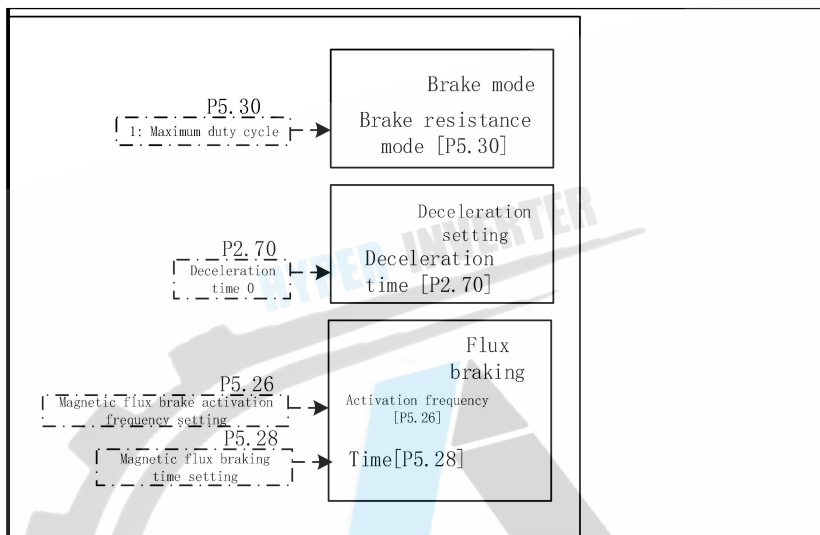

| Parameter No. | Function                                 | Setting value | Note   |
|---------------|--|---------------|--|
| P2.70         | Deceleration time 0                      | 1             | Deceleration time is set to 1s                     |
| P5.26         | Magnetic flux brake activation frequency | 100           | The flux brake activation frequency is set to 100% |
| P5.28         | Flux braking time                        | 3             | The flux braking time is set to 3s                 |
| P5.71         | Current limit                            | 180           | The current limit is set to 180%                   |
| P5.30         | Brake resistance mode                    | 1             | Choose the maximum duty cycle                      |

## Control terminal switching macro

| Control terminal switching macro (P1.20 = 60)   |
|---|
| When there is multi-speed signal, it is given by multi-speed, and when there is no multi-speed signal, it is given by keyboard. |
| · The setting frequency can be selected by multi-speed or keyboard.   |
| · Use external terminals S4 and S5.   |

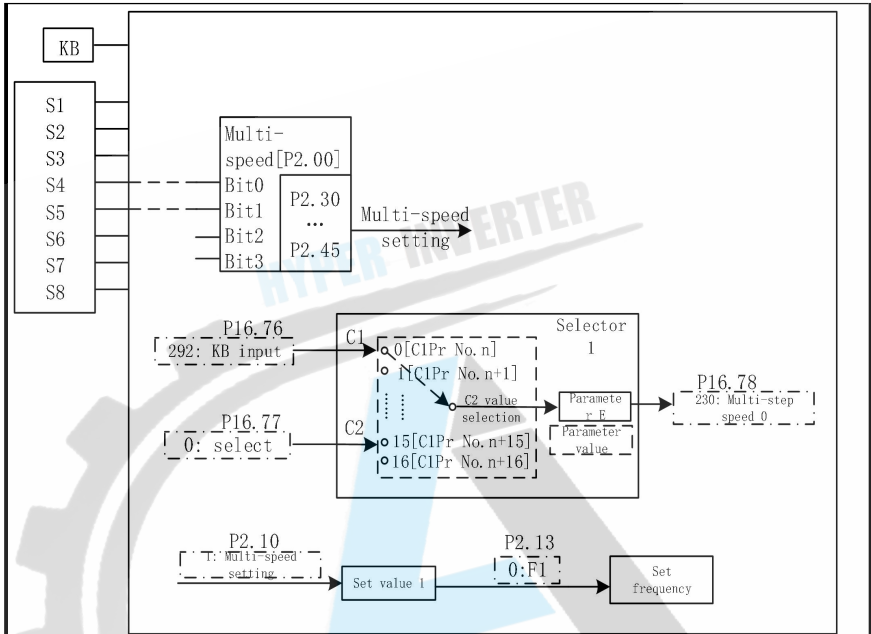

| Parameter No. | Function                           | Setting value | Note  |
|---------------|------------------------------------|---------------|---|
| P2.92         | Keyboard settings                  | *             | Source keyboard potentiometer                         |
| P2.31         | Multi-speed 1                      | 30            | Multi-speed 1 is set to 15HZ                          |
| P2.32         | Multi-speed 2                      | 40            | Multi-speed 2 is set to 20HZ                          |
| P2.33         | Multi-speed 3                      | 50            | Multi-speed 3 is set to 25HZ                          |
| P16.76        | Selector 1 parameter source        | 292           | Selector 1 parameter source is keyboard setting value |
| P16.77        | Selector 1 setting                 | 0             | Selector 1 is set to 0                                |
| P16.78        | Selector 1 destination parameters  | 230           | The purpose parameter of selector 1 is multi-speed    |
| P2.10         | Setpoint source 1                  | 1             | Set value source 1 is multi-speed                     |
| P2.13         | Set channel relationship selection | 0             | Set the channel relationship selection to F1          |
| P2.00         | Multi-speed source                 | 11000         | Multi-speed selection for external terminals S4, S5   |

### Frequency arrival macro

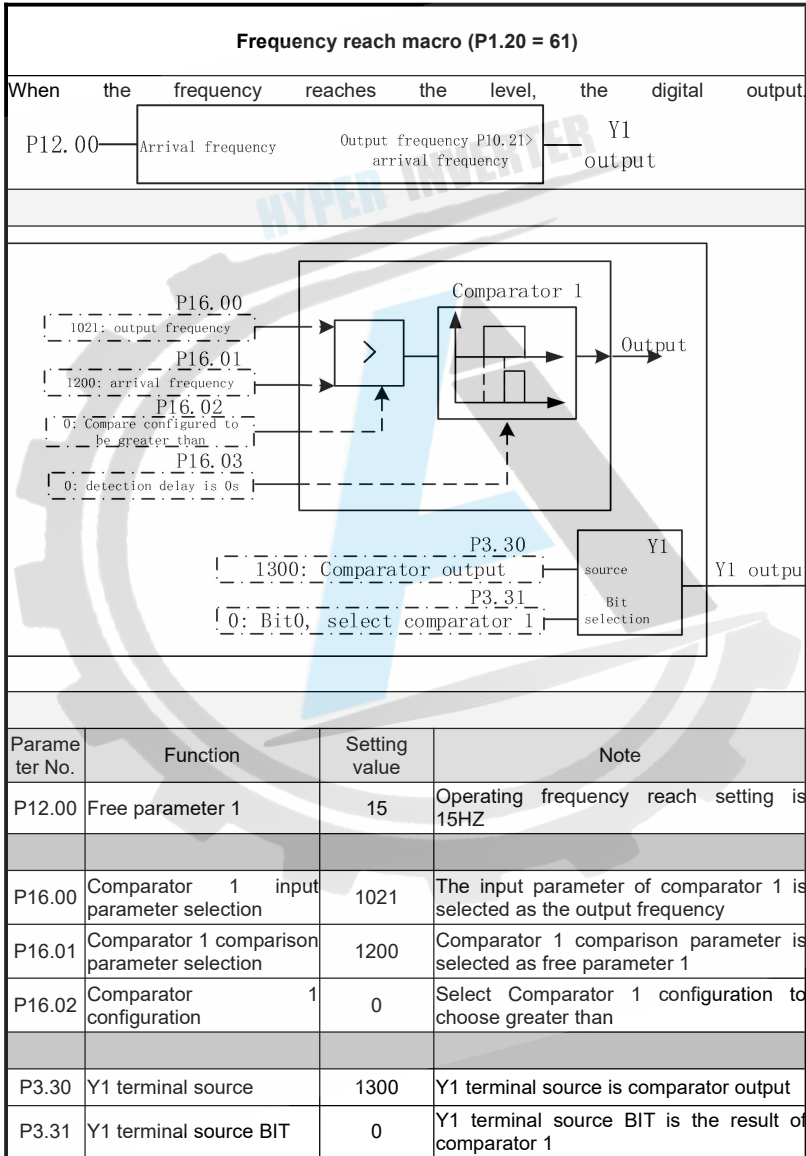

### FDT macro

| FDT macro (P1.20 = 62)                                   |   |
|--|---|
| When the frequency reaches the range, the digital output |   |
| P12.00 — Upper limit                                     | <div style="border: 1px solid black; padding: 5px; display: inline-block;">                     Upper limit &gt; Output frequency<br/>                     P10.21 &gt; Lower limit                 </div> — Y1 output |
| P12.01 — Lower limit                                     |   |



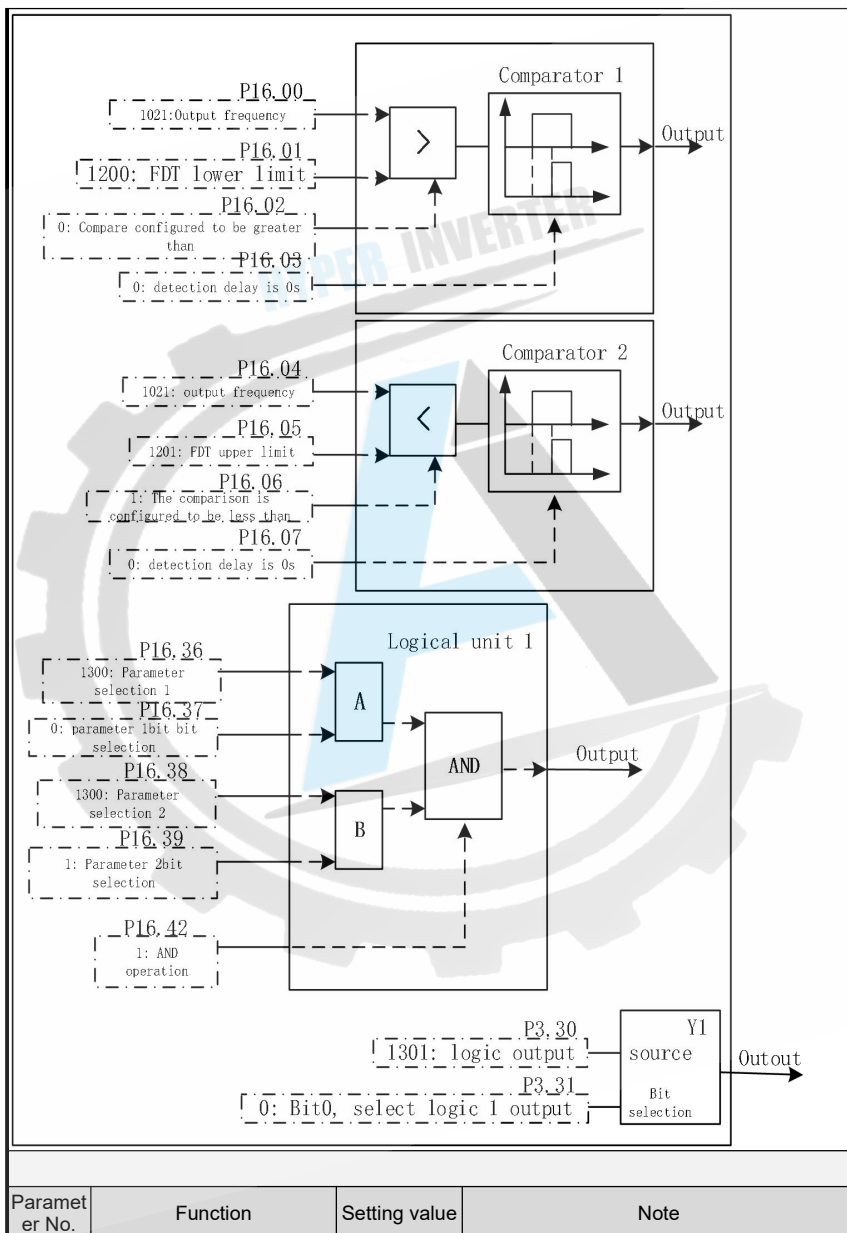

| Parameter No. | Function | Setting value | Note |
|---------------|----------|---------------|------|
|---------------|----------|---------------|------|

|        |   |      |   |
|--------|---|------|---|
| P12.00 | Free parameter 1                            | 20   | The lower limit of FDT is set to 20HZ                                   |
| P12.01 | Free parameter 2                            | 35   | The upper limit of FDT is set to 35HZ                                   |
|        |   |      |   |
| P16.00 | Comparator 1 input parameter selection      | 1021 | The input parameter of comparator 1 is selected as the output frequency |
| P16.01 | Comparator 1 comparison parameter selection | 1200 | Comparator 1 comparison parameter is selected as free parameter 1       |
| P16.02 | Comparator 1 configuration                  | 0    | Select Comparator 1 configuration to choose greater than                |
| P16.04 | Comparator 2 input parameter selection      | 1021 | The input parameter of comparator 2 is selected as the output frequency |
| P16.05 | Comparator 2 comparison parameter selection | 1201 | Comparator 2 comparison parameter is selected as free parameter 1       |
| P16.06 | Comparator 2 configuration                  | 1    | Select Comparator 2 configuration to select less than                   |
| P16.36 | Logic unit 1 parameter selection 1          | 1300 | Logic unit 1 parameter selection 1 is the comparator output             |
| P16.37 | Logic unit 1 input bit selection 1          | 0    | Logic unit 1 input bit is selected as comparator 1                      |
| P16.38 | Logic unit 1 parameter selection 2          | 1300 | Logic unit 1 parameter selection 2 is the comparator output             |
| P16.39 | Logic unit 1 input bit selection 2          | 1    | Logic unit 1 input bit selection 2 is comparator 2                      |
| P16.42 | Logical unit 1 configuration 1              | 1    | Logical unit 1 is configured with                                       |
|        |   |      |   |
| P3.30  | Y1 terminal source                          | 1301 | Y1 terminal source is logic output                                      |
| P3.31  | Y1 terminal source BIT                      | 0    | Y1 terminal source BIT bit is the result of logic unit 1                |

## Acceleration / deceleration switching macro

**Macro for acceleration / deceleration switching (P1.20 = 63)**

When the frequency reaches the level, the acceleration and deceleration are switched

P12.00 — Acceleration time switching frequency point

P12.02~P12.03 — Acceleration time

P12.01 — Deceleration time switching frequency point

P12.04~P12.05 — Deceleration time

# H1 series vector control inverter manual V1.0

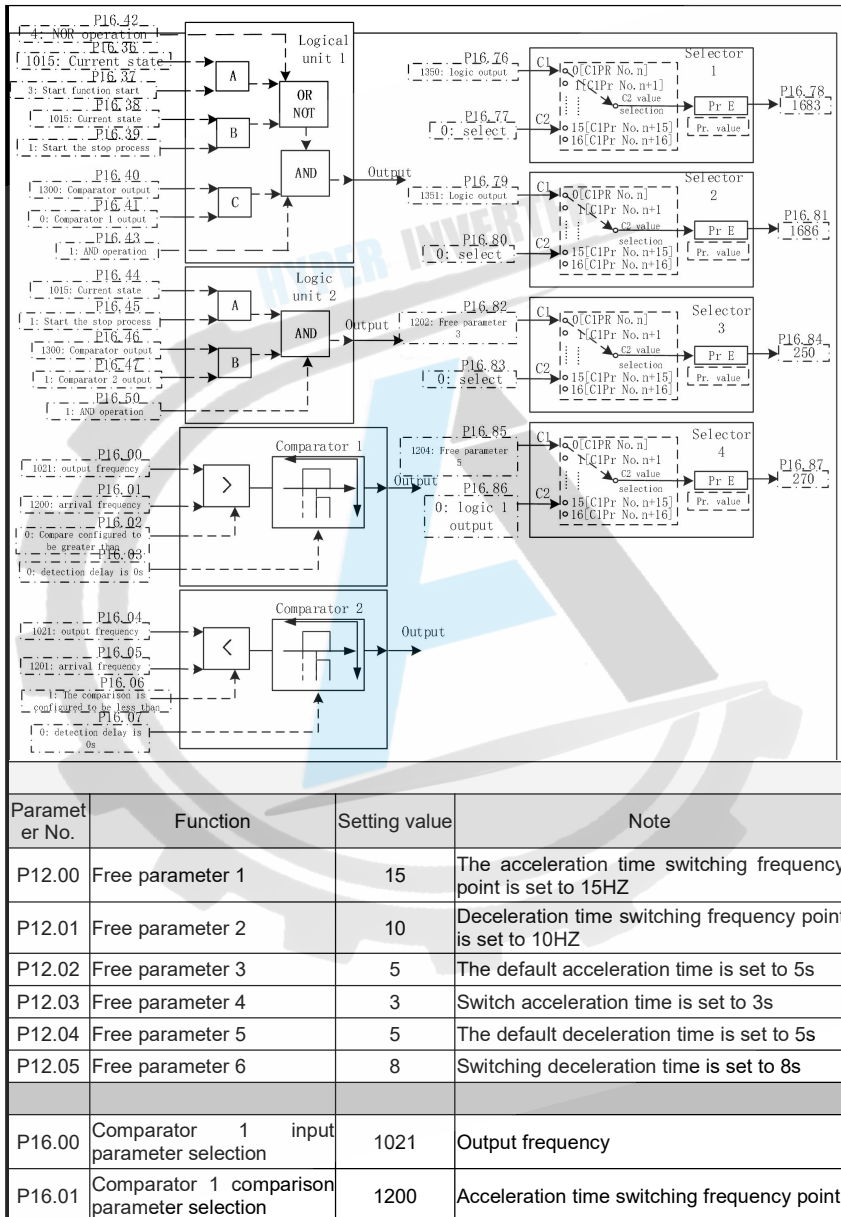

## H1 series vector control inverter manual V1.0

|        |   |      |   |
|--------|---|------|---|
| P16.02 | Comparator 1 configuration                  | 0    | Configuration selection is greater than     |
| P16.04 | Comparator 2 input parameter selection      | 1021 | Output frequency                            |
| P16.05 | Comparator 2 comparison parameter selection | 1201 | Deceleration time switching frequency point |
| P16.06 | Comparator 2 configuration                  | 1    | Configuration selection is less than        |
| P16.36 | Logic unit 1 parameter selection 1          | 1015 | Current status                              |
| P16.37 | Logic unit 1 input bit selection 1          | 3    | Start function start                        |
| P16.38 | Logic unit 1 parameter selection 2          | 1015 | Current status                              |
| P16.39 | Logic unit 1 input bit selection 2          | 1    | Stop process starts                         |
| P16.40 | Logic unit 1 parameter selection 3          | 1300 | Comparator output                           |
| P16.41 | Logic unit 1 input bit selection 3          | 0    | Comparator 1 output                         |
| P16.42 | Logical unit 1 configuration 1              | 4    | Configuration 1 is NOR                      |
| P16.43 | Logical unit 1 configuration 2              | 1    | Configuration 2 is with                     |
| P16.44 | Logic unit 2 parameter selection 1          | 1015 | Current status                              |
| P16.45 | Logic unit 2 input bit selection 1          | 1    | Stop process starts                         |
| P16.46 | Logic unit 2 parameter selection 2          | 1300 | Comparator output                           |
| P16.47 | Logic unit 2 input bit selection 2          | 1    | Comparator 2 output                         |
| P16.50 | Logical unit 2 configuration 1              | 1    | Configuration 1 is with                     |
|        |   |      |   |
| P16.76 | Selector 1 parameter source                 | 1350 | Logic output 1                              |
| P16.77 | Selector 1 setting                          | 0    | Logical choice                              |
| P16.78 | Selector 1 destination parameters           | 1683 | Selector 3 settings                         |
| P16.79 | Selector 2 parameter source                 | 1351 | Logic output 2                              |
| P16.80 | Selector 2 settings                         | 0    | Logical choice                              |
| P16.81 | Selector 2 destination parameters           | 1686 | Selector 4 settings                         |
| P16.82 | Selector 3 parameter source                 | 1202 | Default acceleration time                   |
| P16.83 | Selector 3 settings                         | 0    | Acceleration time selection                 |

|        |                                   |      |                             |
|--------|-----------------------------------|------|-----------------------------|
| P16.84 | Selector 3 destination parameters | 250  | Acceleration time 0         |
| P16.85 | Selector 4 parameter source       | 1204 | Default deceleration time   |
| P16.86 | Selector 4 settings               | 0    | Deceleration time selection |
| P16.87 | Selector 4 destination parameters | 270  | Deceleration time 0         |

**Brake signal macro**

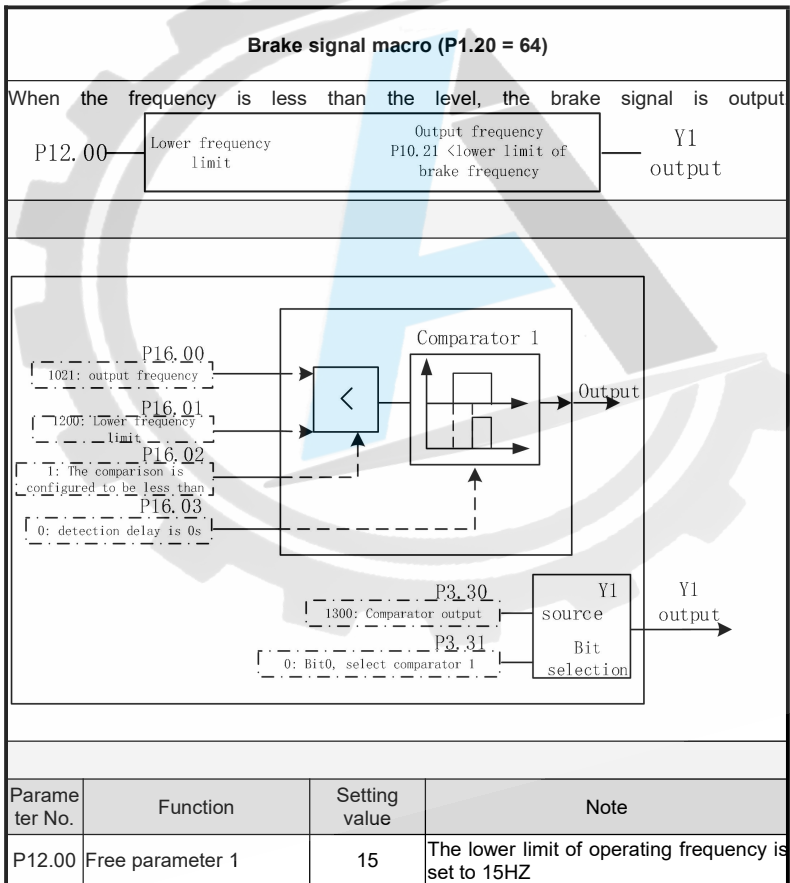

|        |   |      |   |
|--------|---|------|---|
| P16.00 | Comparator 1 input parameter selection      | 1021 | The input parameter of comparator 1 is selected as the output frequency |
| P16.01 | Comparator 1 comparison parameter selection | 1200 | Comparator 1 comparison parameter is selected as free parameter 1       |
| P16.02 | Comparator configuration                    | 1    | Select Comparator 1 configuration to select less than                   |
| P3.30  | Y1 terminal source                          | 1300 | Y1 terminal source is comparator output                                 |
| P3.31  | Y1 terminal source BIT                      | 0    | Y1 terminal source BIT is the result of comparator 1                    |

### 6.16 Release brake signal macro

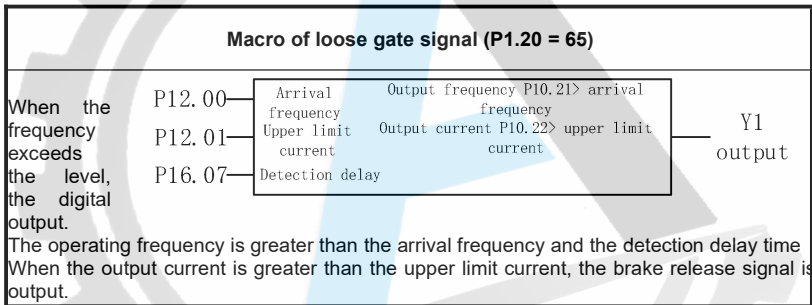

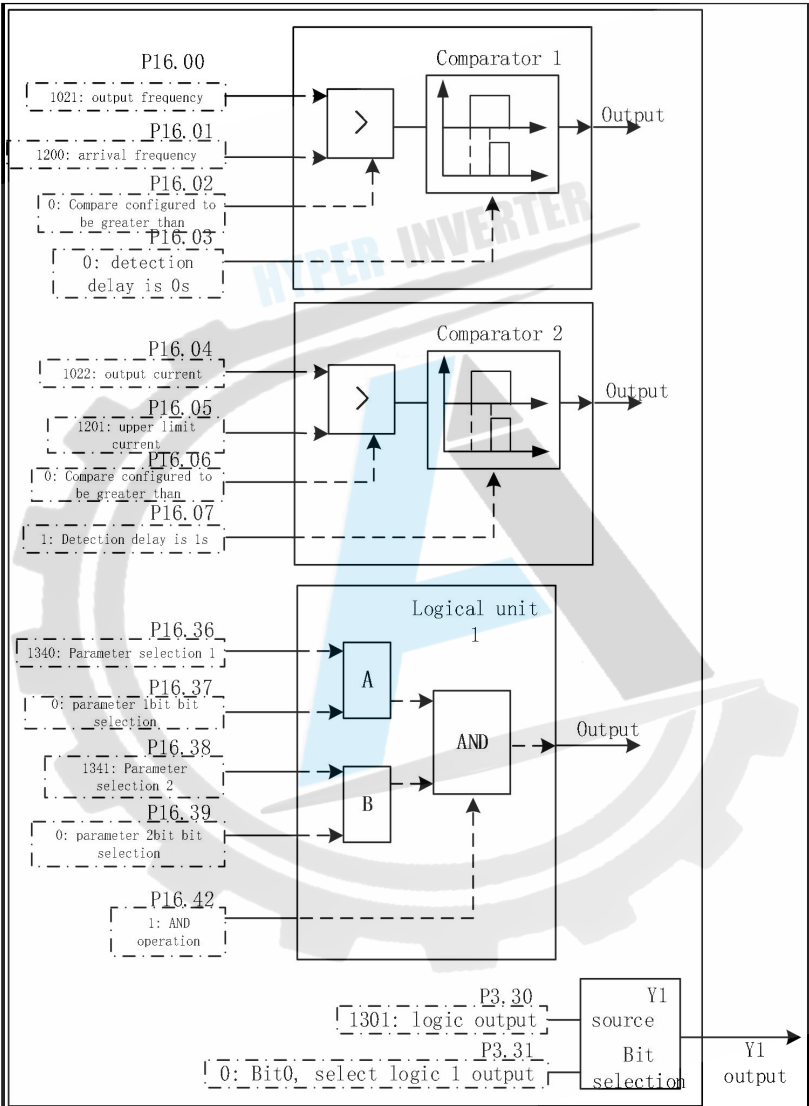

| Parame<br>ter No. | Function | Setting<br>value | Note |
|-------------------|----------|------------------|------|
|-------------------|----------|------------------|------|

|        |   |      |   |
|--------|---|------|---|
| P12.00 | Free parameter 1                            | 25   | Arrival frequency is set to 25HZ  |
| P12.01 | Free parameter 2                            | 15   | The upper limit current is set to 15A                                   |
| P16.00 | Comparator 1 input parameter selection      | 1021 | The input parameter of comparator 1 is selected as the output frequency |
| P16.01 | Comparator 1 comparison parameter selection | 1200 | Comparator 1 comparison parameter is selected as free parameter 1       |
| P16.02 | Comparator 1 configuration                  | 0    | Select Comparator 1 configuration to choose greater than                |
| P16.04 | Comparator 2 input parameter selection      | 1022 | The input parameter of comparator 2 is selected as the output current   |
| P16.05 | Comparator 2 comparison parameter selection | 1201 | Comparator 2 comparison parameter is selected as free parameter 2       |
| P16.06 | Comparator 2 configuration                  | 0    | Select Comparator 2 configuration to choose greater than                |
| P16.07 | Comparator 2 delay time                     | 1    | Comparator 2 delay time is 1S   |
| P16.36 | Logic unit 1 parameter selection 1          | 1340 | Logic unit 1 parameter selection 1 is the comparator output             |
| P16.37 | Logic unit 1 input bit selection 1          | 0    | Logic unit 1 input bit is selected as comparator 1                      |
| P16.38 | Logic unit 1 parameter selection 2          | 1341 | Logic unit 1 parameter selection 2 is the comparator output             |
| P16.39 | Logic unit 1 input bit selection 2          | 0    | Logic unit 1 input bit selection 2 is comparator 2                      |
| P16.42 | Logical unit 1 configuration 1              | 1    | Logical unit 1 is configured with                                       |
| P3.30  | Y1 terminal source                          | 1301 | Y1 terminal source is logic output                                      |
| P3.31  | Y1 terminal source BIT                      | 0    | Y1 terminal source BIT bit is the result of logic unit 1                |

### Break Band Detection Macro

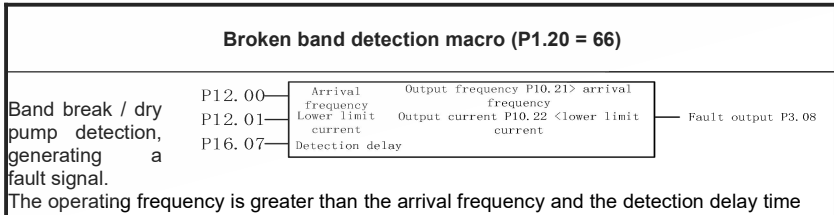

| When the output current is less than the lower limit current, the output is faulty. |   |               |   |
|---|---|---------------|---|
| Parameter No.   | Function                                    | Setting value | Note  |
| P12.00  | Free parameter 1                            | 25            | Arrival frequency is set to 25HZ  |
| P12.01  | Free parameter 2                            | 5             | The lower limit current is set to 5A                                    |
|   |   |               |   |
| P16.00  | Comparator 1 input parameter selection      | 1021          | The input parameter of comparator 1 is selected as the output frequency |
| P16.01  | Comparator 1 comparison parameter selection | 1200          | Comparator 1 comparison parameter is selected as free parameter 1       |
| P16.02  | Comparator 1 configuration                  | 0             | Select Comparator 1 configuration to choose greater than                |
| P16.04  | Comparator 2 input parameter selection      | 1022          | The input parameter of comparator 2 is selected as the output current   |
| P16.05  | Comparator 2 comparison parameter selection | 1201          | Comparator 2 comparison parameter is selected as free parameter 1       |
| P16.06  | Comparator 2 configuration                  | 1             | Select Comparator 2 configuration to select less than                   |
| P16.07  | Comparator 2 delay time                     | 10.000        | Comparator 2 delay time is 10.000S                                      |
| P16.36  | Logic unit 1 parameter selection 1          | 1340          | Logic unit 1 parameter selection 1 is the comparator output             |
| P16.37  | Logic unit 1 input bit selection 1          | 0             | Logic unit 1 input bit is selected as comparator 1                      |
| P16.38  | Logic unit 1 parameter selection 2          | 1341          | Logic unit 1 parameter selection 2 is the comparator output             |
| P16.39  | Logic unit 1 input bit selection 2          | 0             | Logic unit 1 input bit selection 2 is comparator 2                      |
| P16.42  | Logical unit 1 configuration 1              | 1             | Logical unit 1 is configured with                                       |
|   |   |               |   |
| P1.30   | Virtual terminal setting                    | 1350          | Virtual terminal setting selection logic output 1                       |
| P3.08   | Source of fault command                     | 17            | The fault command comes from the virtual terminal setting bit0          |

## Signal loss macro

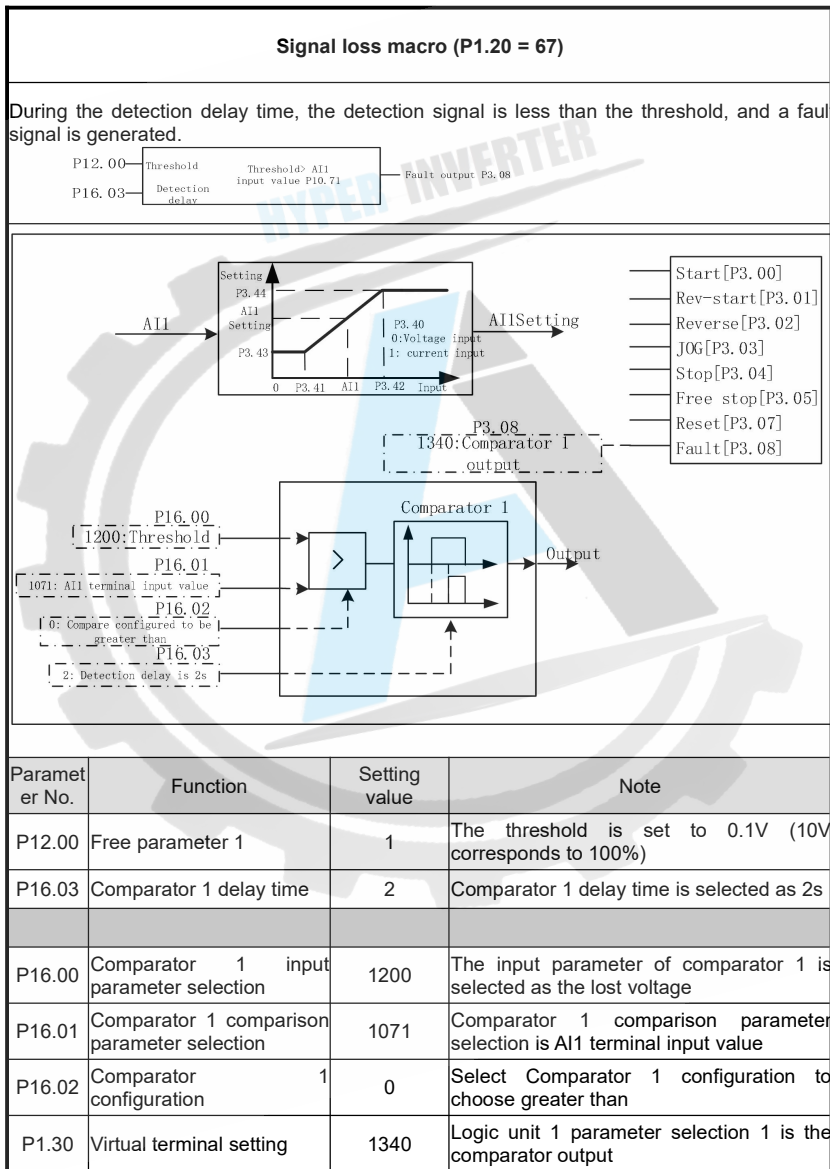

|       |                         |    |  |
|-------|-------------------------|----|--|
| P3.08 | Source of fault command | 17 | The fault command comes from the virtual terminal setting Bit0 |
|-------|-------------------------|----|--|

### Internal control eight-stage speed macro

**Internal control eight-stage speed macro (P1.20 = 68)**

- The internal control eight-stage timing switching speed.
- The external terminal uses S4 as the start signal.
- Cyclic execution.

S4端子 内控八段速使能  
P18.04~P18.11 定时时间  
P12.00~P12.08 多段速

当前段速

| Parame No. | Function                      | Setting value | Note |
|------------|-------------------------------|---------------|------|
| P16.26     | Terminal input                |               |      |
| P16.37     | Select S4 as the start signal |               |      |
| P16.38     | Select free parameters        |               |      |
| P16.39     | Free parameter selection      |               |      |
| P16.42     | AND operation                 |               |      |
| P18.01     | Loop operation                |               |      |
| P18.04     | Multi-speed time 1            |               |      |
| P18.05     | Multi-speed time 2            |               |      |
| P18.06     | Multi-speed time 3            |               |      |
| P18.07     | Multi-speed time 4            |               |      |
| P18.08     | Multi-speed time 5            |               |      |
| P18.09     | Multi-speed time 6            |               |      |
| P18.10     | Multi-speed time 7            |               |      |
| P18.11     | Multi-speed time 8            |               |      |
| P16.85     | Selector 4                    |               |      |
| P16.86     | Logic output                  |               |      |
| P16.76     | Selector 1                    |               |      |
| P16.82     | Selector 3                    |               |      |
| P16.79     | Selector 2                    |               |      |
| P16.87     | PrE                           |               | 1802 |
| P16.78     | PrE                           |               | 1680 |
| P16.84     | PrE                           |               | 1802 |
| P16.81     | Pr                            |               | 230  |

## H1 series vector control inverter manual V1.0

|        |                                    |      |  |
|--------|------------------------------------|------|--|
| P12.00 | Free parameter 1                   | 0    | Stop frequency is set to 0HZ   |
| P12.01 | Free parameter 2                   | 10   | Multi-speed 1 is set to 5HZ  |
| P12.02 | Free parameter 3                   | 20   | Multi-speed 2 is set to 10HZ   |
| P12.03 | Free parameter 4                   | 30   | Multi-speed 3 is set to 15HZ   |
| P12.04 | Free parameter 5                   | 40   | Multi-speed 4 is set to 20HZ   |
| P12.05 | Free parameter 6                   | 50   | Multi-speed 5 is set to 25HZ   |
| P12.06 | Free parameter 7                   | 60   | Multi-speed 6 is set to 30HZ   |
| P12.07 | Free parameter 8                   | 70   | Multi-speed 7 is set to 35HZ   |
| P12.08 | Free parameter 9                   | 80   | Multi-speed 8 is set to 40HZ   |
| P18.04 | Timer 1 phase 1 time               | 3    | Multi-speed time 1 is set to 3s  |
| P18.05 | Timer 1 phase 2 time               | 4    | Multi-speed time 2 is set to 4s  |
| P18.06 | Timer 1 phase 3 time               | 5    | Multi-speed time 3 is set to 5s  |
| P18.07 | Timer 1 phase 4 time               | 6    | Multi-speed time 4 is set to 6s  |
| P18.08 | Timer 1 phase 5 time               | 7    | Multi-speed time 5 is set to 7s  |
| P18.09 | Timer 1 phase 6 time               | 8    | Multi-speed time 6 is set to 8s  |
| P18.10 | Timer 1 phase 7 time               | 9    | Multi-speed time 7 is set to 9s  |
| P18.11 | Timer 1 phase 8 time               | 10   | Multi-speed time 8 is set to 10s   |
| P16.37 | Logic unit 1 input bit selection 1 | 3    | Select S4 as the start signal, 0 is S1, 1 is S2 ...  |
| P18.01 | Timer 1 working mode               | 1    | The working mode starts from multi-speed 1 to multi-speed 8 and runs cyclically. If it is set to 0, it will only run once. |
| P18.00 | Timer 1 clock source               | 3    | Multi-speed time unit is S   |
| P16.36 | Logic unit 1 parameter selection 1 | 1070 | S terminal input as cycle start signal   |
| P16.38 | Logic unit 1 parameter selection 2 | 1211 | Select high level signal   |
| P16.39 | Logic unit 1 input bit selection 2 | 0    | Select high level signal   |
| P16.42 | Logical unit configuration 1       | 1    | S terminal input high level signal is valid  |
| P12.09 | Free parameter 10                  | 5    | S terminal without input timing pause  |
| P12.10 | Free parameter 11                  | 3    | If set to 8: S terminal has no input, the current set frequency = stop frequency   |
| P12.11 | Free parameter 12                  | 1    | If set to 9: S terminal has no input, the current set frequency = multi-speed 1  |
| P16.82 | Selector 3 parameter source        | 1209 | S terminal has input timing start  |
| P16.83 | Selector 3 settings                | 0    | High level signal  |

## H1 series vector control inverter manual V1.0

|        |                                      |      |  |  |
|--------|--------------------------------------|------|--|--|
| P16.84 | Selector 3 destination parameters    | 1802 | Selector 3 parameter source is free parameter 10                                   |  |
| P16.85 | Selector 4 parameter source          | 1350 | Selector 3 is set to 0   |  |
| P16.86 | Selector 4 settings                  | 0    | The destination parameter of selector 3 is the timing controller 1 control command |  |
| P16.87 | Selector 4 destination parameters    | 1683 | Selector 4 parameter source is logic output 1                                      |  |
| P16.76 | Selector 1 parameter source          | 1362 | Selector 4 is set to 0   |  |
| P16.77 | Selector 1 setting                   | 0    | The purpose parameter of selector 4 is set by selector 3.                          |  |
| P16.78 | Selector 1 destination parameters    | 1680 | The parameter source of selector 1 is the current channel of timing controller 1.  |  |
| P16.79 | Selector 2 parameter source          | 1200 | Selector 1 is set to 0   |  |
| P16.80 | Selector 2 settings                  | 0    | The purpose parameter of selector 1 is set by selector 2.                          |  |
| P16.81 | Selector 2 destination parameters    | 230  | Selector 2 parameter source is free parameter 1                                    |  |
| P2.10  | Setpoint source 1                    | 1    | Selector 2 is set to 0   |  |
| P2.13  | Set channel 1 relationship selection | 0    | The destination parameter of selector 2 is multi-speed 0                           |  |
| P16.88 | Selector 5 parameter source          | 1360 | Set value source 1 is multi-speed  |  |
| P16.89 | Selector 5 settings                  | 0    | Set channel 1 relationship to F1   |  |
| P16.90 | Selector 5 destination parameters    | 1290 | Timer count  |  |
| P12.95 | Free parameters 96                   | 1803 | Selector 5 is set to 0   |  |
|        |                                      |      | Save timer count when power off  |  |
| P16.43 | Logical unit configuration 2         | 1    | 0  | Eight-speed memory, the value of P12.90 at power-on is given to the parameter number set in P12.95 |
| P18.03 | Timer 1 set value                    | 0    |  |  |
| P18.12 | Timer 1 phase 9 time                 | 0    | Unused   |  |
| P18.13 | Timer 1 phase 10 time                | 0    | No multi-speed jump  |  |
| P18.14 | Timer 1 phase 11 time                | 0    | Multi-speed time 9 is set to 0s  |  |
| P18.15 | Timer 1 phase 12 time                | 0    | Multi-speed time 10 is set to 0s   |  |
| P18.16 | Timer 1 phase 13 time                | 0    | Multi-speed time 11 is set to 0s   |  |
| P18.17 | Timer 1 phase 14 time                | 0    | Multi-step speed time 12 is set to 0s  |  |
| P18.18 | Timer 1 phase 15 time                | 0    | Multi-step speed time 13 is set to 0s  |  |
| P18.19 | Timer 1 phase 16 time                | 0    | Multi-step speed time 14 is set to 0s  |  |



## Chapter 8 RS485 Communication

### 9.1 Introduction

The inverter can be controlled and monitored by PLC or host computer software via RS-485.

### 9.2 Specifications

Table 9-1

| project               | Instruction                             |
|-----------------------|---|
| way of communication  | RS485                                   |
| Transmission type     | Single master and multiple slaves       |
| Number of connections | Max 31                                  |
| Transmission distance | Maximum 1200m (recommended within 700m) |

Table 9-2

| project               | Instruction                        |
|-----------------------|------------------------------------|
| Communication speed   | 2400, 4800, 9600, 19200, 38400 bps |
| Control sequence      | Asynchronous communication         |
| Communication Systems | Half duplex                        |
| Stop bit length       | 0,1,1.5,2 bit                      |
| Data bit              | 8, 9 bit                           |
| Parity check          | No check, even check, odd check    |

### 9.3 Communication protocol

The complete Modbus query message includes: device address, function code, sent data, and error detection field. At the same time, the message returned by the device also includes the device address, function code, any data that needs to be returned, and the error detection field. If an error occurs during message reception, or the slave device cannot execute its command, the slave device will create an error message and send a response.

**Format description**

Table 9-3 Communication format

| Address | Function code | Data code | CRC check |
|---------|---------------|-----------|-----------|
| 8bits   | 8bits         | N*8bits   | 16bits    |

- 1) Address: 1-247 (namely the address of the slave connected to a PC);
- 2) Function code: supported functions (see Table 9-4);
- 3) Data code: data content  $N \times 8\text{bits}$ ;
- 4) CRC check: CRC check value;

Table9-4 Functional coding

| Function code | Instruction                             |
|---------------|---|
| 0x03          | Read holding register                   |
| 0x06          | Preset single register (16-bit mode)    |
| 0x10          | Preset multiple registers (32-bit mode) |

Address coding

In order to be compatible with different host computers, 16-bit and 32-bit access methods can be used for the same parameter. The corresponding addresses are shown in the table below. When using the 16-bit method, please note that the parameter value must be within the 16-bit expression range.表 9-5 Address coding rules

| Parameter value | Address                      | RAM address                          |
|-----------------|------------------------------|--------------------------------------|
| 16 位            | Parameter number - 1         | Parameter number - 1 + 32768         |
| 32bit           | Parameter number - 1 + 16384 | Parameter number - 1 + 16384 + 32768 |

Note: When writing by address, the parameter value will be stored in the inverter EEPROM. Frequent storage of EEPROM will reduce the service life of EEPROM, so when there is no need to store, just change the value in RAM, then use the RAM address to write the parameters.

Table 9-6 Common Address Table

Set the frequency (write only), see the parameters P2.10 ~ P2.14 to enable the communication settings

| Function | Parameter number | 16-bit mode | 32-bit mode | note |
|----------|------------------|-------------|-------------|------|
|          |                  |             |             |      |

|                               |           |                                   |                                   |  |
|-------------------------------|-----------|-----------------------------------|-----------------------------------|--|
| Communi-<br>cation<br>setting | P2.9<br>0 | EEPROM:0<br>121H<br>RAM:<br>8121H | EEPROM:<br>4121H<br>RAM:C121<br>H | P1.47 = 0, upper computer 0 ~ 100000<br>corresponds to 0 ~ maximum frequency<br>P2.18;<br>P1.47 = 1, upper computer 0 ~ 10000<br>corresponds to 0 ~ maximum frequency<br>P2.18;<br>P1.47 = 2, upper computer 0 ~ 1000<br>corresponds to 0 ~ maximum frequency<br>P2.18;<br>P1.47 = 3, upper computer 0 ~ 100<br>corresponds to 0 ~ maximum frequency<br>P2.18; |
|-------------------------------|-----------|-----------------------------------|-----------------------------------|--|

Control commands (write only), see the parameters P3.00 ~ P3.09 to enable the corresponding communication commands

| Function                            | Para-<br>meter<br>num-<br>ber | 16-bit<br>mode                    | 32-bit<br>mode                    | Command<br>word (Bit) | note                       |
|-------------------------------------|-------------------------------|-----------------------------------|-----------------------------------|-----------------------|----------------------------|
| Communi-<br>cation<br>comman-<br>ds | P2.9<br>1                     | EEPROM:<br>0122H<br>RAM:8122<br>H | EEPROM:4<br>122H<br>RAM:C122<br>H | 0                     | start up                   |
|                                     |                               |                                   |                                   | 1                     | Reverse                    |
|                                     |                               |                                   |                                   | 2                     | Start reverse              |
|                                     |                               |                                   |                                   | 3                     | JOG                        |
|                                     |                               |                                   |                                   | 4                     | stop                       |
|                                     |                               |                                   |                                   | 5                     | Emergency stop             |
|                                     |                               |                                   |                                   | 6                     | Safe stop                  |
|                                     |                               |                                   |                                   | 7                     | Reset                      |
|                                     |                               |                                   |                                   | 9                     | Parameter<br>self-learning |
|                                     |                               |                                   |                                   | 11                    | time out                   |
| 13                                  | UP (incremental)              |                                   |                                   |                       |                            |
| 14                                  | DOWN<br>(decreasing)          |                                   |                                   |                       |                            |

Inverter status (read only)

| Function          | Para-<br>meter<br>num-<br>ber | 16-bit<br>mode | 32-bit<br>mode | Command<br>word (Bit) | note                    |
|-------------------|-------------------------------|----------------|----------------|-----------------------|-------------------------|
| Current<br>status | P10.<br>15                    | 03F6H          | 43F6H          | 0                     | Powering off            |
|                   |                               |                |                | 1                     | Stopping                |
|                   |                               |                |                | 2                     | running                 |
|                   |                               |                |                | 3                     | Start function start    |
|                   |                               |                |                | 4                     | Parameter<br>self-study |
|                   |                               |                |                | 5                     | Operating               |
|                   |                               |                |                | 6                     | Ready                   |

|  |  |  |  |    |                 |
|--|--|--|--|----|-----------------|
|  |  |  |  | 10 | malfunction     |
|  |  |  |  | 11 | Call the police |
|  |  |  |  | 12 | STO status      |

Inverter failure (read only)

| Function    | Parameter number  | 16-bit mode | 32-bit mode | Command word (Bit) | note                         |
|-------------|-------------------|-------------|-------------|--------------------|------------------------------|
| Fault state | P10.16            | 03F7H       | 43F7H       | 1                  | System abnormality           |
|             |                   |             |             | 4                  | Ground fault                 |
|             |                   |             |             | 5                  | Short circuit to ground      |
|             |                   |             |             | 6                  | Output short circuit         |
|             |                   |             |             | 7                  | Output overcurrent           |
|             |                   |             |             | 8                  | DC bus overvoltage           |
|             |                   |             |             | 9                  | DC bus undervoltage          |
|             |                   |             |             | 10                 | Inverter overheating         |
|             |                   |             |             | 13                 | Rectifier bridge overheating |
|             |                   |             |             | 14                 | U phase missing phase        |
|             |                   |             |             | 15                 | Phase V missing phase        |
|             |                   |             |             | 16                 | W phase missing phase        |
|             |                   |             |             | 19                 | No motor connection          |
|             |                   |             |             | 20                 | Input phase loss             |
|             |                   |             |             | 21                 | Inverter overload            |
|             |                   |             |             | 22                 | Overtorque                   |
| 24          | Motor overheating |             |             |                    |                              |
| 25          | Motor overload    |             |             |                    |                              |
| 26          | Current limit     |             |             |                    |                              |
| 27          | Input power down  |             |             |                    |                              |

Inverter data (read only)

| Function             | Parameter number | 16-bit mode | 32-bit mode | Data range           | Unit |
|----------------------|------------------|-------------|-------------|----------------------|------|
| Output frequency     | P10.21           | 03FCH       | 43FCH       | -65535.0~65535.0     | Hz   |
| Output current       | P10.22           | 03FDH       | 43FDH       | 0.00~65535.00        | A    |
| The output voltage   | P10.23           | 03FEH       | 43FEH       | 0.0~65535.0          | V    |
| Output torque        | P10.24           | 03FFH       | 43FFH       | 0.000~65535.000      | NM   |
| DC voltage           | P10.25           | 0400H       | 4400H       | 0.0~65535.0          | V    |
| Inverter temperature | P10.26           | 0401H       | 4401H       | 0~65535              | °C   |
| power                | P10.30           | 0405H       | 4405H       | 0.000~65535.000      | kw   |
| power consumption    | P10.31           | 0406H       | 4406H       | 0.000~4294967.295    | Kw*h |
| Operating hours      | P10.40           | 040FH       | 440FH       | 0~4294967295(16 Hex) | h    |

|                           |        |       |       |                      |   |
|---------------------------|--------|-------|-------|----------------------|---|
| Number of power-on        | P10.41 | 041FH | 441FH | 0~4294967295(16 Hex) |   |
| S terminal input status   | P10.70 | 042DH | 442DH | 0~4294967295(16 Hex) |   |
| AI1 terminal input value  | P10.71 | 042EH | 442EH | -65535.000~65535.000 | % |
| AI2 terminal input value  | P10.72 | 042FH | 442FH | -65535.000~65535.000 | % |
| Y terminal output status  | P10.74 | 0431H | 4431H | 0~4294967295(16 Hex) |   |
| AO1 terminal output value | P10.75 | 0432H | 4432H | -65535.000~65535.000 | % |
| AO2 terminal output value | P10.76 | 0433H | 4433H | -65535.000~65535.000 | % |

## 9.4 Read holding register

Read the data in the holding register, taking parameter P10.16 fault status and parameter P2.30 multi-stage speed 0 as an example.

Fault state (example)

Read the value of inverter parameter P10.16, it can be known from the fault status table, just read 16 bits, then the register address = 1016-1 = 1015 (03F7H).

Send data: 01 03 03 F7 00 01 35 BC

Receive data: 01 03 02 00 0A 38 43

P10.15 = 10 (000AH). The fault state is that the inverter is overheated. (See fault code)

### Send data

|                  |                 |
|------------------|-----------------|
| Slave address    | 01H             |
| function code    | 03H             |
| Register address | 03H (high byte) |
|                  | F7H (low byte)  |
| data             | 00H (high byte) |
|                  | 01H (low byte)  |
| CRC check        | 35H (low byte)  |
|                  | BCH (high byte) |

### Receive data

|  |                 |
|--|-----------------|
| Slave address                          | 01H             |
| function code                          | 03H             |
| Number of data<br>(Calculated in Byte) | 02H             |
| data                                   | 00H (high byte) |
|  | 0AH (low byte)  |
| CRC check                              | 38H (low byte)  |
|  | 43H (high byte) |

Multi-speed 0 (example)

## H1 series vector control inverter manual V1.0

Read the value of inverter parameter P2.30, when accessed with 32 bits, the register address =  $230-1 + 16384 = 16613$  (40E5H).

Send data: 01 03 40 E5 00 02 C0 3C

Receive data: 01 03 04 00 00 88 B8 9C 41

The read data is 35000 (88B8H), which shows that P2.30 = 35.000

### Send data

|  |                 |
|--|-----------------|
| <b>Slave address</b>                           | 01H             |
| <b>function code</b>                           | 03H             |
| <b>Number of data<br/>(Calculated in Byte)</b> | 40H (high byte) |
|  | E5H (low byte)  |
| <b>data</b>                                    | 00H (high byte) |
|  | 02H (low byte)  |
| <b>CRC check</b>                               | C0H (low byte)  |
|  | 3CH (high byte) |

### Receive data

|  |                 |
|--|-----------------|
| <b>Slave address</b>                           | 01H             |
| <b>function code</b>                           | 03H             |
| <b>Number of data<br/>(Calculated in Byte)</b> | 04H             |
| <b>data<br/>(High byte)</b>                    | 00H (high byte) |
|  | 00H (low byte)  |
| <b>data<br/>(Low byte)</b>                     | 88H (high byte) |
|  | B8H (low byte)  |
| <b>CRC check</b>                               | 9CH (low byte)  |
|  | 41H (high byte) |

## Preset a single register

Write the value of inverter parameter P5.00, when accessed with 16 bits, the register address =  $500-1 = 499$  (01F3H).

Send data: 01 06 01 F3 00 01 B9 C5

Receive data: 01 06 01 F3 00 01 B9 C5

### Send data

|  |                 |
|--|-----------------|
| <b>Slave address</b>                           | 01H             |
| <b>function code</b>                           | 06H             |
| <b>Number of data<br/>(Calculated in Byte)</b> | 01H (high byte) |
|  | F3H (low byte)  |
| <b>data</b>                                    | 00H (high byte) |
|  | 01H (low byte)  |
| <b>CRC check</b>                               | B9H (low byte)  |
|  | C5H (high byte) |

### Receive data

|                      |     |
|----------------------|-----|
| <b>Slave address</b> | 01H |
|----------------------|-----|

|                         |                 |
|-------------------------|-----------------|
| <b>function code</b>    | 06H             |
| <b>Register address</b> | 01H (high byte) |
|                         | F3H (low byte)  |
| <b>data</b>             | 00H (high byte) |
|                         | 01H (low byte)  |
| <b>CRC check</b>        | B9H (low byte)  |
|                         | C5H (high byte) |

## Preset multiple registers

Write the value of parameter P2.91, when accessed with 32 bits, the register address = 291-1 + 16384 = 16674 (4122H) Table 9-7 Command control word table

| Parameter value (Bit) | Control word            |
|-----------------------|-------------------------|
| 0                     | start up                |
| 1                     | Reverse                 |
| 2                     | Start reverse           |
| 3                     | JOG                     |
| 4                     | stop                    |
| 5                     | Emergency stop          |
| 6                     | Safe stop               |
| 7                     | Reset                   |
| 9                     | Parameter self-learning |
| 10                    | Jump                    |
| 11                    | time out                |
| 13                    | UP (incremental)        |
| 14                    | DOWN (decreasing)       |

Taking the stop control word as an example, the value of parameter 2.91 is set to 16.

Send data: 01 10 41 22 00 02 04 00 00 00 10 4D F1

Receive data: 01 10 41 22 00 02 F5 FE (hexadecimal)

### Send data

|  |                 |
|--|-----------------|
| <b>Slave address</b>                           | 01H             |
| <b>function code</b>                           | 10H             |
| <b>Register address</b>                        | 41H (high byte) |
|  | 22H (low byte)  |
| <b>Number of registers<br/>(16 bits)</b>       | 00H (high byte) |
|  | 02H (low byte)  |
| <b>Number of data<br/>(Calculated in Byte)</b> | 04H             |
| <b>data<br/>(High byte)</b>                    | 00H (high byte) |
|  | 00H (low byte)  |
| <b>data<br/>(Low byte)</b>                     | 00H (high byte) |
|  | 10H (low byte)  |
|  | 4DH (low byte)  |

|                  |                 |
|------------------|-----------------|
| <b>CRC check</b> | F1H (high byte) |
|------------------|-----------------|

**Receive data**

|  |                 |
|--|-----------------|
| <b>Slave address</b>                     | 01H             |
| <b>function code</b>                     | 10H             |
| <b>Register address</b>                  | 41H (high byte) |
|  | 22H (low byte)  |
| <b>Number of registers<br/>(16 bits)</b> | 00H (high byte) |
|  | 02H (low byte)  |
| <b>CRC check</b>                         | F5H (low byte)  |
|  | FEH (high byte) |

**Communication error codes**

The inverter returns data when a communication error occurs. The format is shown in Table 9-8. Communication error function code = request function code + 128.

Table 9-8 Communication error data format

| <b>Address</b> | <b>Function code</b> | <b>Fault code</b> | <b>CRC</b> |
|----------------|----------------------|-------------------|------------|
| 8bits          | 8bits                | 8bits             | 16bits     |

Table 9-9 Error function code description

| <b>error code</b> | <b>Explanation</b>   |
|-------------------|--|
| 0x00              | Parameter does not exist   |
| 0x01              | Cannot write defined parameters  |
| 0x02              | The value of the parameter exceeds the upper limit of the parameter                      |
| 0x07              | Unchangeable   |
| 0x0B              | Not allowed to write   |
| 0x11              | The data of the defined parameters cannot be changed in the current mode of the inverter |
| 0x12              | Other errors   |
| 0x40              | Invalid data address   |
| 0x41              | Invalid length   |
| 0x42              | Invalid data length and value  |
| 0x43              | Invalid parameter  |
| 0x82              | No bus connection for defined parameters   |
| 0x83              | The factory set value has been selected data and cannot be changed                       |

## Chapter 9 Fault Resolution and repair

### 9.1 Protection function



**Warning**

The inverter must be rectified before the fault is reset, otherwise it may result in reduced product life and damage to other equipment.

### 9.2 Fault code table

| Fault code | Protective function          | Explanation  |
|------------|------------------------------|--|
| 1          | System abnormality           | Inverter hardware failure or software failure.   |
| 4          | Ground fault                 | The resistance value to the ground is abnormal and leakage occurs.   |
| 5          | Short circuit to ground      | Short circuit to ground.   |
| 6          | Output short circuit         | When the output current of the inverter is greater than 250% of the rated current of the inverter, the inverter turns off the output.                      |
| 7          | Output overcurrent           | When the output current of the inverter is greater than 200% of the rated current of the inverter, the inverter turns off the output.                      |
| 8          | DC bus overvoltage           | If the DC voltage of the main circuit is higher than 400V (220V model) or 800V (380V model) when the motor decelerates, the inverter shuts off the output. |
| 9          | DC bus undervoltage          | When the input voltage decreases, if the DC voltage of the main circuit is too low, the inverter will turn off the output.                                 |
| 10         | Inverter overheating         | When the temperature of the heat sink is detected to be overheated, the inverter turns off the output.   |
| 11         | Self-learning failure        | The self-learning parameters are incorrect or the motor is abnormal.   |
| 13         | Rectifier bridge overheating | The rectifier module is overheated.  |

|    |                       |  |
|----|-----------------------|--|
| 14 | U phase missing phase | Output U phase loss.   |
| 15 | Phase V missing phase | Output V phase loss.   |
| 16 | W phase missing phase | Output W phase loss.   |
| 19 | No motor connection   | The motor is disconnected during operation.  |
| 20 | Input phase loss      | Input power phase loss   |
| 21 | Inverter overload     | When the output current of the inverter exceeds the rated rating of the inverter (150% for 1 minute), the inverter turns off the output. |
| 22 | Overtorque            | Motor over torque.   |
| 24 | Motor overheating     | The motor temperature is too high.   |
| 25 | Motor overload        | When the output current of the inverter exceeds the rated rating of the motor (150% for 1 minute), the inverter turns off the output.    |
| 26 | Current limit         | The output current exceeds the set limit threshold.  |
| 27 | Input power down      | The input voltage is lower than the power-down level (P5.86).  |
| 63 | User failure          | User-defined fault (see parameter P3.08)   |

### 9.3 Maintenance and inspection prevention



#### Warning

Make sure to remove input power during maintenance.

Make sure that the DC connection capacitor is discharged for maintenance, even if the bus capacitance of the inverter's main circuit is still charged after the power is turned off. Use the detector to check the voltage between P + and P- before proceeding.

H1 series inverters have ESD (electrostatic discharge) sensitive components. During inspection or installation, take protective measures to avoid ESD before touching, do not change any internal parts and connections, and do not change the inverter.

## 9.4 Checkpoint

### ■ Daily inspection

- Appropriate installation environment
- Cooling system failure
- Uncommon shock and noise
- Uncommon overheating and discoloration

### ■ Periodic inspection

- Screws and nuts may be loose due to vibration, temperature changes, etc.  
Check that they are fastened and as tight as possible
- Foreign objects in the cooling system  
Use air to clean
- Check the cooling fan rotation conditions, capacitor conditions and magnetic contactor connection  
If not replaced normally

## 9.5 Parts replacement

The inverter consists of electronic components such as semiconductor devices. Due to structural or physical characteristics, the following components may age, causing the inverter to fail to operate. The components must be replaced periodically.

## Chapter 10 Technical Notes

| project                  |                                     | project description   |
|--------------------------|-------------------------------------|---|
| Output                   | Rated voltage;                      | Three phase, 380~440V, 50Hz/60Hz<br>Single phase, 200V~240V, 50Hz/60Hz  |
|                          | frequency                           | Three phase:320V~460V;Single phase: 180V ~ 260V;<br>Voltage imbalance rate: <3%; frequency: ± 5%  |
| Input                    | Allowable voltage working range     | 0~Rated input voltage   |
|                          | Voltage                             | 0Hz~200Hz   |
|                          | frequency                           | 150% rated current for 1 minute, 180% rated current for 2 seconds   |
| Main control performance | Overload capacity                   | V/F 、 Speed sensorless vector control   |
|                          | control method                      | Space vector PWM modulation   |
|                          | Modulation                          | Asynchronous motor, synchronous motor, single-phase motor (please consult the manufacturer when using)  |
|                          | Motor type                          | 150% rated torque at 0.5Hz  |
|                          | Starting torque                     | 1:100(Without speed sensor)   |
|                          | Speed range                         | Digital setting: maximum frequency ± 0.01%;<br>Analog setting: maximum frequency ± 1%   |
|                          | Frequency accuracy                  | Digital setting: 0.01Hz;<br>Analog setting: maximum frequency 1%  |
|                          | Frequency resolution                | Straight line / S curve acceleration / deceleration   |
|                          | Acceleration and deceleration curve | Automatically limit the current during operation to prevent frequent overcurrent fault tripping   |
|                          | Limiting                            | Support instantaneous stop and automatic frequency reduction  |
| Run function             | Instantaneous power failure         | Keyboard given, terminal given, communication given   |
|                          | Command source                      | Digital setting, analog setting, multi-speed, communication setting   |
|                          | Source settings of                  | Support main given + PID  |
| Operation keyboard       | PID                                 | Display output frequency, output current, output voltage, bus voltage display value 1, display value 2, current alarm, current fault                          |
|                          | Nixie tube display                  | support   |
| Protective function      |                                     | Overcurrent protection, overvoltage protection, undervoltage protection, overheat protection, overload protection, phase loss protection, earth leakage, etc. |
| Environment              | Place of use                        | Indoor, no direct sunlight, no dust, corrosive gas, flammable gas, oil mist   |

|                     |  |  |
|---------------------|--|--|
|                     |  | water vapor, dripping water or salt etc.                                     |
| Altitude            |  | For derating above 1000 meters, derate 10% for every 1000 meters             |
| Ambient temperature |  | -10 °C ~ + 40 °C (Ambient temperature is 40 °C ~ 50 °C, please use derating) |
| humidity            |  | 5% ~ 95% RH, no condensation   |
| storage temperature |  | -40 °C ~ +70 °C  |
| vibration           |  | Less than 5.9 m / s <sup>2</sup> (0.6g)                                      |

## Chapter 11 Selection of braking resistor

### 11.1 Brake resistor configuration table

| Voltage level | Inverter power | Braking unit | Braking resistor           |     |        | Braking torque (10%UD) |
|---------------|----------------|--------------|----------------------------|-----|--------|------------------------|
|               |                |              | Power (W) / resistance (Ω) |     | amount |                        |
| 220V          | 0.75KW         | Built-in     | 80                         | 120 | 1      | 100%                   |
|               | 1.5KW          |              | 150                        | 100 | 1      |                        |
|               | 2.2KW          |              | 300                        | 68  | 1      |                        |
|               | 3.7KW          |              | 300                        | 68  | 1      |                        |
|               | 5.5KW          |              | 400                        | 30  | 1      |                        |
|               | 7.5KW          |              | 400                        | 30  | 1      |                        |
| 380V          | 0.75KW         |              | 150                        | 300 | 1      |                        |
|               | 1.5KW          |              | 200                        | 300 | 1      |                        |
|               | 2.2KW          |              | 200                        | 200 | 1      |                        |
|               | 4.0KW          |              | 400                        | 150 | 1      |                        |
|               | 5.5KW          |              | 400                        | 100 | 1      |                        |
|               | 7.5KW          |              | 750                        | 75  | 1      |                        |
|               | 11KW           |              | 1000                       | 60  | 1      |                        |
|               | 15KW           |              | 1500                       | 40  | 1      |                        |
|               | 18.5KW         |              | 2500                       | 30  | 1      |                        |
|               | 22KW           |              | 3000                       | 30  | 1      |                        |

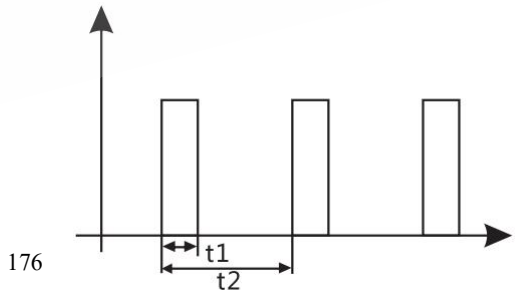

### Precautions:

1. Please select the power number and resistance value recommended by our company
2. The power numbers and electric group values recommended in the above table are calculated according to 100% braking torque and 10% utilization rate. When the load demand and system reliability are met, the resistance power and resistance value can be appropriately increased or decreased; When it is required to increase the braking torque or use a higher power, the power and resistance value of the braking resistor should be changed appropriately, or consult our company.
3. When installing the braking resistor, be sure to consider the safety and non-flammability of the surrounding environment.
4. Braking frequency  $UD = t1 / t2 * 100\%$

t1: braking time within one working cycle

t2 one duty cycle

The braking usage rate doubles and the power of the corresponding braking unit and braking resistor is doubled.

1. In the above table, the resistance value and power greater than 2500W are the total resistance value and power, the power of the resistance

Based on 2500W as the base number, for example, if you need a 2500W 6Ω resistor, you need 10 250W 60Ω resistors in parallel.

Calculation of braking resistor

Statistics show that when the braking current  $I_B$  flowing through the energy-consuming circuit is equal to half of the rated current of the motor, the braking torque of the motor is approximately equal to its rated torque:

$$I_B = I_{MN} / 2 \quad T_B \approx T_{MN} \quad \text{or} \quad I_B = 2U_B / I_{MN}$$

In the formula:

## H1 series vector control inverter manual V1.0

IB—braking current, A; IMN—motor rated current, A; TB—braking torque, N.m;  
TMN—motor rated torque, N.m.

In general, the selection range of braking torque is:

$$TMN < TB < 2TMN \text{ then: } IMN < IB < 2IMN$$

The user can decide the braking current according to the specific situation of the production machinery.

After the braking current is determined, it is easy to calculate the braking resistance:

$$RB = UB / IB \quad RB_{min} = UB / IMN$$

UB is the braking threshold voltage; RB is the resistance of the braking resistor, where UB is generally 1.1 times the rated bus voltage; RBmin is the minimum value of the braking resistor

Common values of braking threshold voltage:

AC220V: DC380V AC380V: DC680V AC660V: DC1140V

Knowing IB and RB can determine the power of the resistor

$\lambda$ : Actual resistance value / calculated value first; ED%: braking utilization rate  
for example:

Suppose an existing 7.5KW motor has a rated current of 18A and a rated input voltage of 380V

Then there are:  $RB = 680V / 9A = 75 \text{ Euro}$

$$RB_{min} = 680/18 = 38 \text{ Euro}$$

75 Euros according to experience

$$\text{Power of braking resistor} = 1 * 680^2 / 75 * 0.1 = 616W$$

In actual use, the power can be properly amplified.

### 11.2 Installation dimension drawing of braking resistor

| rated<br>power<br>r(W) | Size (mm)  |            |            |           |   |    |   |            |   |    |
|------------------------|------------|------------|------------|-----------|---|----|---|------------|---|----|
|                        | L1(±<br>2) | L2(<br>±5) | L3(±<br>3) | D(±2<br>) | B | B1 | H | H1(±<br>3) | N | φd |
|                        |            |            |            |           |   |    |   |            |   |    |

|      |     |     |     |    |     |    |    |     |    |     |
|------|-----|-----|-----|----|-----|----|----|-----|----|-----|
| 80   | 152 | 174 | 196 | 28 | 6.5 | 28 | 28 | 61  | 10 | 4.5 |
| 150  | 195 | 217 | 239 | 40 | 8   | 40 | 41 | 81  | 12 | 5.5 |
| 200  | 195 | 217 | 239 | 40 | 8   | 40 | 41 | 81  | 12 | 5.5 |
| 300  | 282 | 304 | 326 | 40 | 8   | 40 | 41 | 81  | 12 | 5.5 |
| 400  | 282 | 304 | 326 | 40 | 8   | 40 | 41 | 81  | 12 | 5.5 |
| 750  | 316 | 338 | 360 | 50 | 8   | 50 | 45 | 101 | 16 | 6   |
| 1000 | 300 | 325 | 350 | 60 | 8.5 | 60 | 60 | 119 | 16 | 6   |
| 1500 | 415 | 440 | 465 | 60 | 8.5 | 60 | 60 | 119 | 16 | 6   |
| 2000 | 510 | 535 | 560 | 60 | 8.5 | 60 | 60 | 119 | 16 | 6   |
| 2500 | 600 | 625 | 650 | 60 | 8.5 | 60 | 60 | 119 | 16 | 6   |

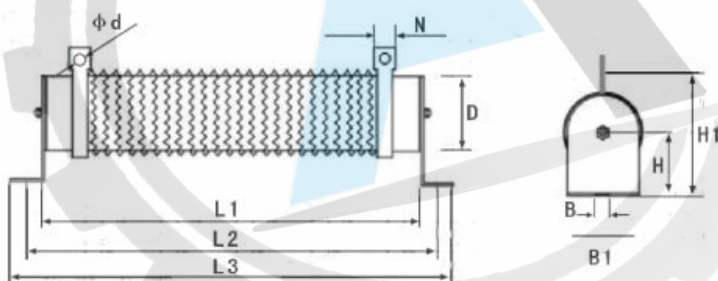

HYPER INVERTER

## Chapter 12 Dimensions

| H1Series structure size table |           |          |          |      |     |   |
|-------------------------------|-----------|----------|----------|------|-----|---|
| Frame number                  | Size (mm) |          |          |      |     |   |
|                               | W(width)  | H (high) | D (deep) | A    | B   | d |
| F1                            | 85        | 170      | 124      | 67.3 | 158 | 5 |
| F2                            | 97        | 194      | 133      | 85   | 184 | 5 |
| F3                            | 126       | 237      | 147      | 112  | 223 | 5 |
| F4                            | 168       | 298      | 160      | 154  | 283 | 6 |
| F5                            | 198       | 355      | 177      | 183  | 338 | 6 |

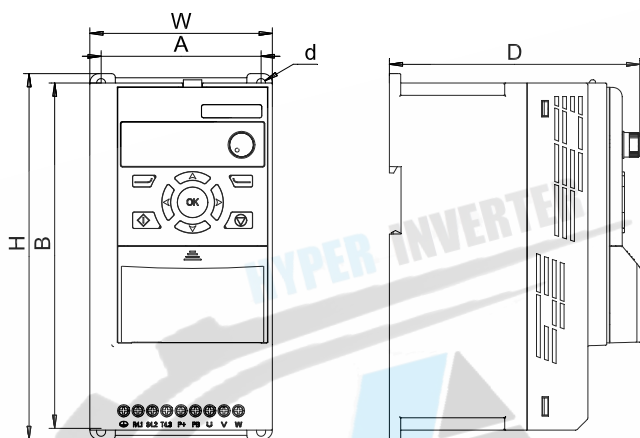

## Chapter 13 Quick parameter configuration table

| Quick parameters | Basic parameters | Function            |
|------------------|------------------|---------------------|
| P0.09            | P1.11            | Parameter operation |
| P0.10            | P2.10            | Setting (frequency) |

|       |       |                                       |
|-------|-------|---------------------------------------|
|       |       | source F1                             |
| P0.11 | P2.11 | Setting (frequency)<br>source F2      |
| P0.12 | P2.13 | Set relationship<br>selection         |
| P0.13 | P2.18 | Maximum setting                       |
| P0.14 | P5.08 | Motor output frequency<br>upper limit |
| P0.15 | P2.00 | Multi-speed source                    |
| P0.16 | P2.30 | Multi-speed 0                         |
| P0.17 | P2.31 | Multi-speed 1                         |
| P0.18 | P2.32 | Multi-speed 2                         |
| P0.19 | P2.33 | Multi-speed 3                         |
| P0.20 | P2.34 | Multi-speed 4                         |
| P0.21 | P2.35 | Multi-speed 5                         |
| P0.22 | P2.36 | Multi-speed 6                         |
| P0.23 | P2.37 | Multi-speed 7                         |
| P0.24 | P2.50 | Acceleration time 0                   |
| P0.25 | P2.70 | Deceleration time 0                   |
| P0.26 | P2.24 | Jog frequency                         |
| P0.30 | P3.00 | Start command source                  |
| P0.31 | P3.01 | Reverse start<br>command source       |
| P0.32 | P3.02 | Reverse command<br>source             |
| P0.33 | P3.03 | Jog command source                    |
| P0.34 | P3.04 | Source of stop<br>command             |
| P0.35 | P3.05 | Free parking order<br>source          |
| P0.36 | P3.07 | Reset command<br>source               |
| P0.37 | P3.20 | S1 type                               |
| P0.38 | P3.21 | S2 type                               |
| P0.39 | P3.22 | S3 type                               |
| P0.40 | P3.30 | Y1 terminal source                    |
| P0.41 | P3.41 | AI1 low-end voltage<br>(current)      |
| P0.42 | P3.42 | AI1 high-end voltage<br>(current)     |
| P0.43 | P3.43 | AI1 low-end settings                  |
| P0.44 | P3.44 | AI1 high-end settings                 |
| P0.45 | P3.61 | AO1 signal source                     |
| P0.46 | P3.62 | AO1 low-end settings                  |
| P0.47 | P3.63 | AO1 high-end settings                 |
| P0.48 | P3.64 | AO1 low-end voltage<br>(current)      |
| P0.49 | P3.65 | AO1 high-end voltage<br>(current)     |
| P0.50 | P4.00 | PID proportional gain                 |
| P0.51 | P4.01 | PID integral gain                     |

## H1 series vector control inverter manual V1.0

|       |       |                        |
|-------|-------|------------------------|
| P0.52 | P4.05 | PID output upper limit |
| P0.53 | P4.06 | PID output lower limit |
| P0.54 | P4.09 | PID range              |
| P0.55 | P4.11 | PID sleep frequency    |
| P0.56 | P4.12 | PID enters sleep time  |
| P0.57 | P4.13 | PID wakeup deviation   |
| P0.58 | P4.14 | PID entry wake-up time |
| P0.59 | P4.15 | PID sleep action       |
| P0.60 | P5.10 | Start function         |
| P0.61 | P5.11 | Start Time             |
| P0.62 | P5.12 | Start frequency        |
| P0.63 | P5.19 | DC injection current   |
| P0.64 | P5.20 | Stop function          |
| P0.65 | P5.21 | Stop frequency         |
| P0.66 | P5.22 | DC braking current     |
| P0.67 | P5.23 | DC braking time        |
| P0.68 | P5.30 | Brake resistance mode  |
| P0.70 | P5.00 | control method         |
| P0.71 | P6.05 | Carrier frequency      |
| P0.72 | P6.11 | Motor Power            |
| P0.73 | P6.12 | Motor voltage          |
| P0.74 | P6.13 | Motor frequency        |
| P0.75 | P6.14 | Motor current          |
| P0.76 | P6.15 | Motor speed            |
| P0.78 | P7.71 | VF curve-F1            |
| P0.79 | P7.72 | VF curve-F2            |
| P0.80 | P7.73 | VF curve-F3            |
| P0.81 | P7.74 | VF curve-F4            |
| P0.82 | P7.75 | VF curve -V0           |
| P0.83 | P7.76 | VF curve-V1            |
| P0.84 | P7.77 | VF curve-V2            |
| P0.85 | P7.78 | VF curve-V3            |
| P0.86 | P7.79 | VF curve-V4            |

Note: The parameter table in the H1 series inverter simple manual is a shortcut parameter, please refer to the above table for the mapping to the basic parameters. After the data of the shortcut parameter is changed, the corresponding basic parameter will also be changed; after the data of the basic parameter is changed, the corresponding shortcut parameter will also be changed.

## Chapter 14 Standard card (H10001) instructions for

### use

#### 15.1 Overview

The H10001 card is a multi-functional I / O standard card for use with H1 series inverters. It can realize 4 digital inputs, 1 relay output and 1 analog input. It also has an RS-485 communication interface (integrated in Ethernet port), can be connected to the external keyboard.

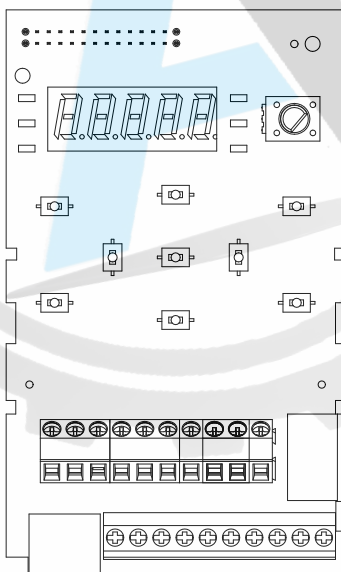

Schematic diagram of standard card distribution

## Mechanical installation

Please install it when the inverter is completely powered off; align the pins (26 pins) on the function card and the inverter power board and insert tightly.

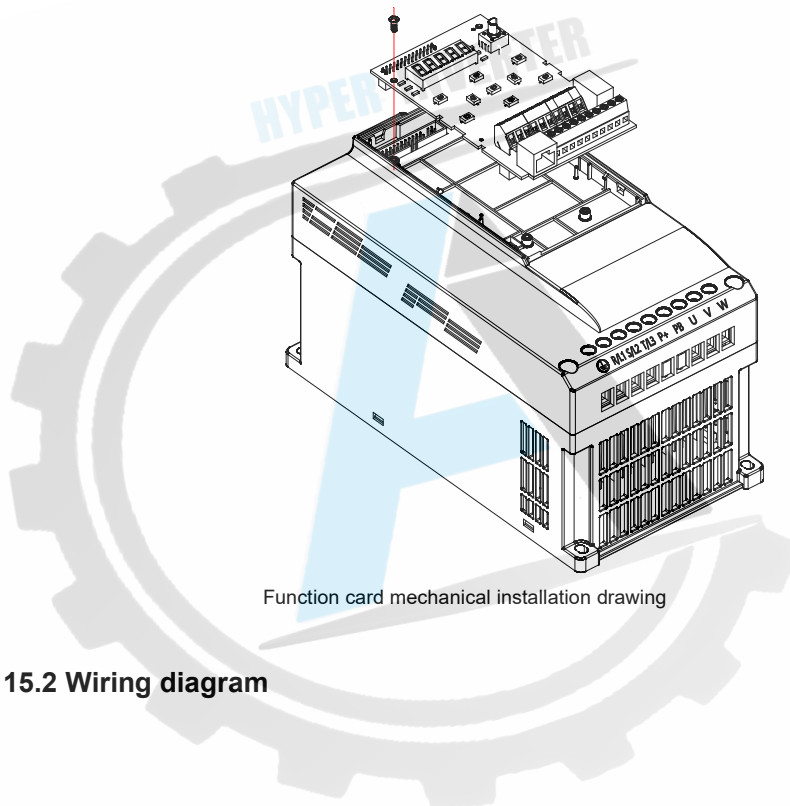

Function card mechanical installation drawing

## 15.2 Wiring diagram

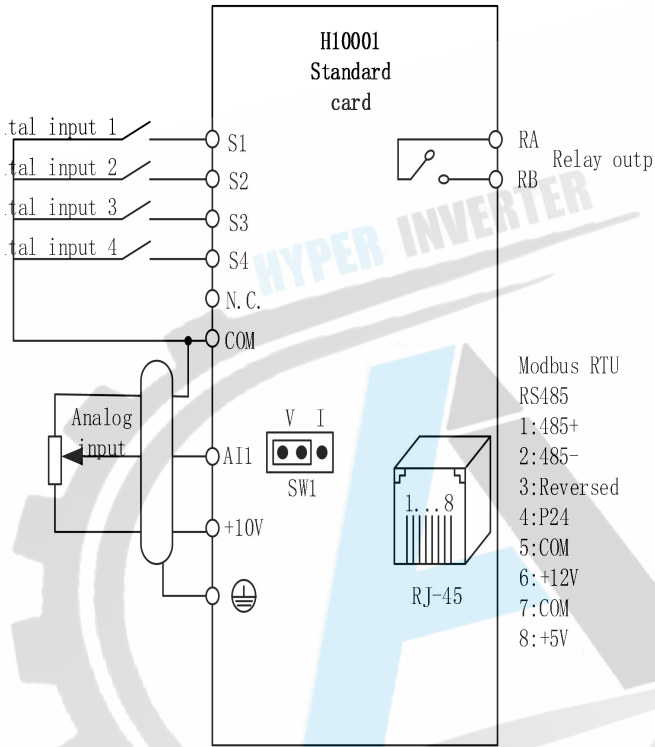

### 15.3 Control terminal

#### Terminal specifications

| Terminal symbol | Terminal name         | Function Description   |
|-----------------|-----------------------|--|
| +10V            | 10V power supply      | Provide + 10V power to the outside, maximum output current 50mA  |
| AI1             | Analog input terminal | 1. Input voltage range: DC 0V ~ 10V<br>2. Input current range: 0 ~ 20mA<br>1、 Select voltage or current through SW1 jumper |
| COM             | Digital, analog       | Internally isolated from communication ground GND  |

|       |                        |  |
|-------|------------------------|--|
| S1~S4 | Digital input terminal | 1. Optocoupler isolation<br>2. Input impedance: 2.4kΩ<br>3. Voltage range during level input, 9V ~ 30V |
| N.C.  | Set aside              | Reserved terminal  |
| RA RB | Relay output           | 1、 Resistive load: 250VAC 3A / 30VDC 3A;<br>2、 Inductive load: 250VAC 0.2A / 24VDC 0.1A (cosØ = 0.4)   |
| RJ45  | Network port           | The keyboard can be externally connected or connected to the host computer                             |

### Terminal wiring

A. Digital input terminal:

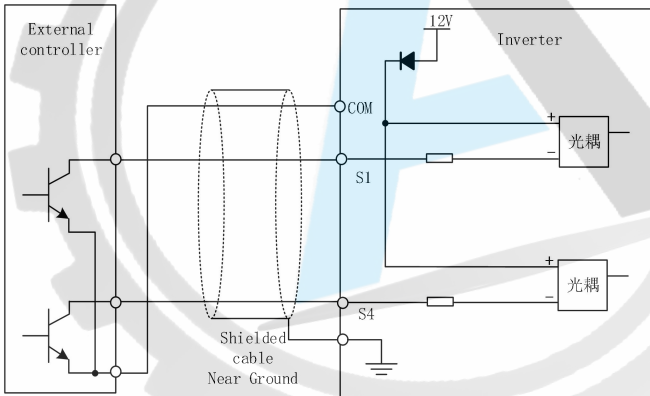

### Digital input terminal wiring

Note: The wiring method of the digital input terminal of the standard configuration card is NPN type. If the user needs other wiring methods, please consult our technical staff.

B. Analog input terminal:

Because weak analog voltage signals are particularly susceptible to external interference, shielded cables are generally required, and the wiring distance should be as short as possible, not exceeding 20 meters. As shown below:

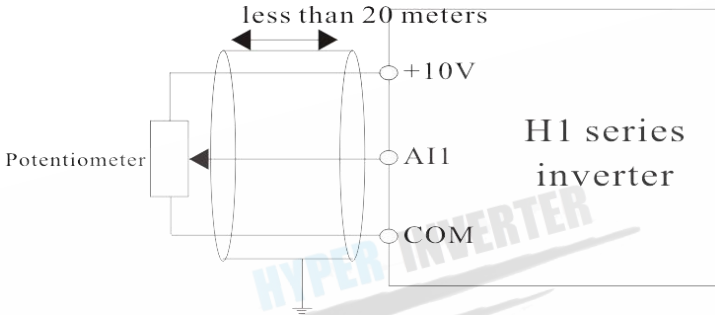

Schematic diagram of analog input terminal wiring

In some occasions where the analog signal is severely interfered, the analog signal source needs to add a filter capacitor or a ferrite core. As shown below:

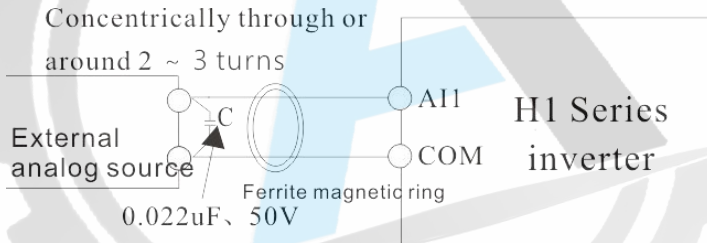

Wiring diagram of analog input terminal plus filter processing

