

H
Y
P
E
R



I
N
V
E
R
T
E
R

SSInverter
High performance
V/F & Vectore
Close loop
SSI800





User Manual-EN

Preface

Thanks for choosing the SSI800 modularity family, including its vector frequency converter, control unit and other modules.

Before using the products, please read the manual first to make sure the performance and specification of the products are fully understood, so that the products can be installed and operated safely and achieve the best value for the customer. Specifically, the manual describes the demands for maintenance and reconditioning of the products, please read the manual or download relevant materials from our website when needed.

Only professional electrical engineer is allowed to install or debug the product wherever high voltage is applied. In the manual, some information is marked with  (Caution) or  (Danger) to warn of the safety demands for moving, installing, operating and testing the products. Please follow the demands. If any question, please contact us for professional advices.

Please be noticed that the SSI800 is a family of different modules. You can order different modules separately and some modules can run separately. You can build up your own product combination based on your demands. Below modules are illustrated in this manual: Power Unit (abbreviated as PU, functions to achieve the power conversion, motor control, protection etc.), Control Unit (abbreviated as CU, functions to achieve application control, control terminal and/or human interface), keypad, option cards and other options.

To fulfil more and more demands from the customer, we may upgrade our products and the manual as well, you may not receive the notification if no special agreement is made. Please keep attention to our website or consult us if any change happens.

Contents

Chapter 1 Overview of the SSI800 Modules	3
1.1 Type and Specification of main Power Unit of SSI800	3
1.1.1 Nameplate for SSI800 Power Unit(PU00/PU01)	4
1.1.2 Main specifications and models for SSI800 Power Unit (PU00/PU01)	5
1.1.3 Specification	6
1.1.4 Derating requirement	6
1.2 SSI800 Control Unit (CU)	6
1.3 Option cards	7
1.3.1 Description of name plate	7
1.3.2 Main specification and Models of option cards	7
1.4 SSI800 Keypad	8
1.4.1 Description of the Name plate of keypad	8
1.4.2 Main specification and model of keypad	8
1.5 Other options supported in SSI800	9
1.6 Guidance for use SSI800 modules in combination	9
1.6.1 Power Units work alone	9
1.6.2 Combine the Control Unit with Power Unit	9
1.6.3 Use option card or keypad on Control Unit	10
Chapter 2 Operation Instruction for SSI800 Power Units	11
2.1 Safety Instruction for Power Units of SSI800	11
2.1.1 Before Power On	11
2.1.2 With Power on	12
2.1.3 Running	12
2.1.4 Power Off	12
2.2 Mechanical and Electrical Installation	12
2.2.1 Mechanical Installation	12
2.2.1.1 Installation Environment	12
2.2.1.2 Outline and Installation Dimensions	13
2.2.1.3 Product Installation	14
2.2.2 Auxilliary Components Installation	15
2.2.2.1 Selection Guide for air switch, fuse and contactor	16
2.2.2.2 Selection Guide for Brake Resistor	17
2.2.2.3 Selection for input/output AC choke	17
2.2.2.4 Selection for Filters	19
2.2.3 Electrical Instructions	21
2.2.3.1 Electrical Diagram	21
2.2.3.2 Power Terminals	24
2.2.3.3 Recommended Specifications for Power Circuits installation	26
2.2.3.4 Guidance for Selection of Residual-Current Circuit Breaker	27
2.2.3.5 Control Terminals	27
2.2.4 EMC Guidance for Electrical Wiring	28

2.2.4.1 EMC Standards	28
2.2.4.2 Guidance for EMC Noise Handling	28
2.2.4.3 Leakage Current Handling	28
2.2.4.4 Handling the Induced Voltage	28
2.2.4.5 Grounding	29
2.3 List of Parameters	29
2.4 Detailed Description for Parameters	38
2.4.1 Parameter Group 0: General Control Mode and Commands	38
2.4.2 Group 1 Basics for Inverter and Motor Control	42
2.4.3 Parameter Group 2: Digital Terminal Functions	49
2.4.4 Parameter Group 3: Analogue Terminal Functions	54
2.4.5 Parameter Group 4: Process PID and Other Controllers	57
2.4.6 Parameter Group 5: Limitation, Protection and Failure Detection	59
2.4.7 Parameter Group 6: Keypad Operation and Display	63
2.4.8 Parameter Group 7: Auxilliary and Special Functions	64
2.4.9 Parameter Group 8: Basic and Running Information	66
2.4.10 Parameter Group 9: Real Time Runing Status Monitoring	67
2.5 Application Quick Guide	68
2.6 Fault Handling: Warning, Alarm and Error	68
2.6.1 List of the Faults	68
2.6.2 How to Get the Fault Info	70
2.7 Maintenance	70
2.7.1 Routine Inspection	71
2.7.2 Maintenance	71
2.7.3 The storage and transportation of product	71
2.7.4 Scrapping of the product	71
Chapter 3 Operation Instruction for SSI800 Control Unit CU00	72
3.1 Mechanic and Electric Installation	72
3.1.1 Outline Dimensions	72
3.1.2 Electrical Diagram	73
3.1.3 Terminals	74
3.1.3.1 Specification of the terminals	74
3.1.3.2 Guidance for Connecting Wires	75
3.1.3.3 Electrical connection for Digital Inputs	75
3.1.3.4 Electrical connection for Digital Outputs	76
3.2 Keypad Operation Guidance	76
3.2.1 How to Set Parameter	77
3.2.2 Monitor the Product Status	77
3.2.3 Check the Fault Log (Warning or Alarm Log)	77
3.2.4 Comparison Table for Character Displaying	78
3.3 CU00 Application Quick Guide and Notes	78
Chapter 4 Instruction for other Options of SSI800	79
4.1 External Keypad AD-KP01	79
4.2 External Keypad AD-KP02	79
4.3 Option Cards AD-PG01/AD-PG02/AD-PG03	79
4.4 Option Cards AD-DPI/AD-PNI	79
Chapter 5 Operation Instruction for SSI800 Combination Type	80
5.1 Nameplate for Combination Type	80
5.2 Specification and Function for Combination Type	80
5.3 Safety Instruction for Combination Type	80
5.4 Installation and Wiring for Combination Type	80
5.5 Operation for Combination Type	80
5.6 Maintenance	80
Chapter 6 SSI800 Basic Application Guide	81
6.1 Control with Keypad	81
6.2 Control with Terminals	81
6.3 Reset the parameters to Factory Defaults	81
6.4 Reset the Faults (Alarms)	81
6.5 Motor Parameters Auto Tuning	81
Appendix A. Modbus Communication Guidance new	82
IO Extension Cards	86
PG Cards	91
PG04 WIFI Cards	95
PROFINET	100
SOLAR DRIVE FOR PUMP WITH SSI800	106

Chapter 1 Overview of the SSI800 Modules

SSI800 is a family of different modules, as listed below:

Name	Type	Specification	Function Description
Power Unit	PU00	200~240V: 0.37~2.2kW 380~480V: 0.75~450kW	Power Conversion, motor speed or torque control, a Control Unit is must to run the motor
	PU01	200~240V: 0.37~2.2kW 380~480V: 0.75~22kW	Power Conversion, motor speed or torque control, can run the motor with its built-in DI/DO/Modbus
Control Unit	CU00	6DI+2AI+AO+DO+2Relay+RS485 5 Digits LED Keypad One option card socket	Application control, control terminal and/or Keypad, or support option cards
Keypad	KP01	5 digits LED, incremental potential meter	Local operation, status monitoring, parameter set/read or copy
	KP02	7line LCD, USB/Wi-Fi, real time clock	Local operation, status monitoring, parameter set/read or copy, SW update, Wireless control
Option Cards	PG01	12V/24V 150mA, 50KHz	Common mode incremental encoder
	PG02	5V 200Ma,200KHz	Differential mode incremental encoder
	PG03	5~7V, 10KHz, 2/4/6/8 poles	Resolver for speed/position sense
	DP01	DPV1	Profibus-DP
	PN01	IO, RT, IRT	Profinite
Din-rail Option	DR1	Only up to 2.2Kw	For din-rail mounting
Panel-Through Option	PT4-PT7	Only from 11Kw to 90Kw	For panel-through mounting
Decoupling Plate	ED1-ED5	Only up to 22Kw	For grounding the shielding of control wire and power cable

NOTE : a. Customize design for Control Unit is possible and compatible for all Power Unit
b. More option cards are coming later

Below are several examples of the combination of different modules possible for application

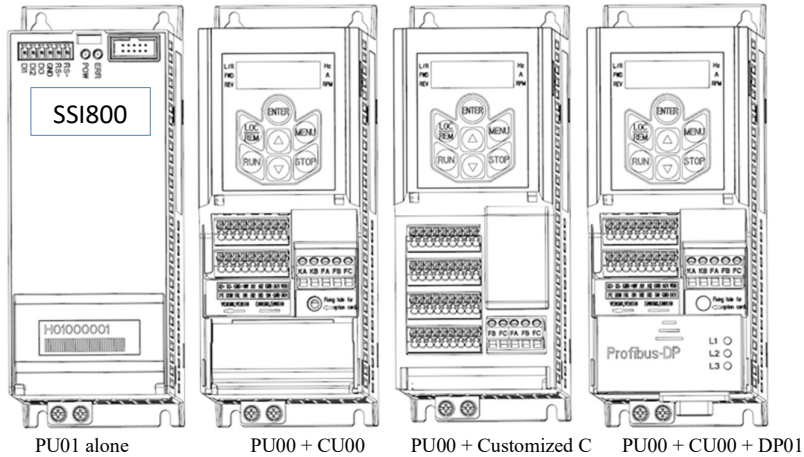

1.1 Type and Specification of main Power Unit of SSI800

Currently two series of Power Unit can be ordered, listed as below:

Type Name	Power Range	Difference
PU00	0.37KW-450KW	No DI/DO/RS485 and no LED for status
PU01	0.37KW-22KW	2DI/1DO/1RS485 for control and 2LEDs for monitoring

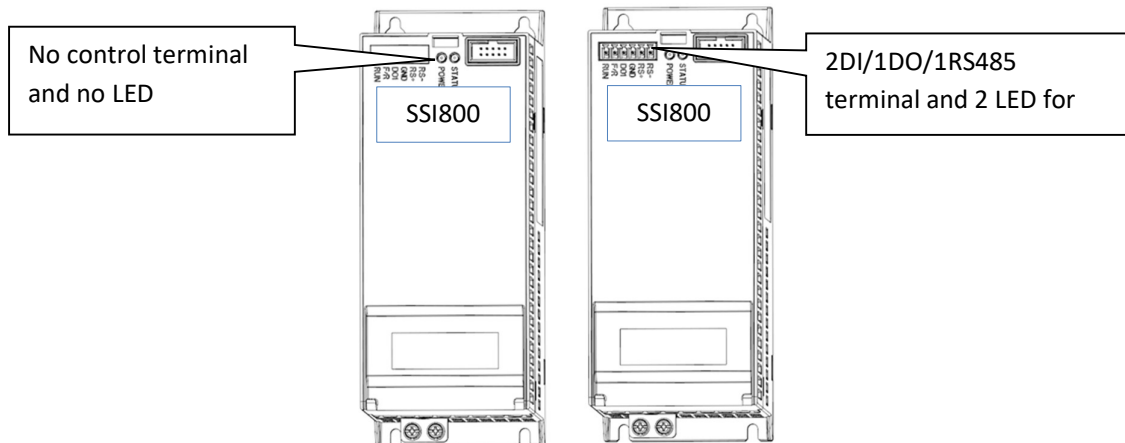

1.1.1 Nameplate for SSI800 Power Unit (PU00/PU01)

Description of the Name Plate

Item	Description
1	Logo
2	Type code
3	Power input specification
4	Power output specification
5	Bar code
6	Order number
7	Warning information
8	Company name
9	QC Pass
10	Country of origin



The nameplate features the SSInverter Co.,Ltd logo (1) at the top. Below it, the model number (2) is SSI800-4T3R7GB/5R5PB-V00 3.785.5KW. The input specification (3) is 3x380V-480V 15A/18.6A, and the output specification (4) is 3x0Vin 0-59Hz 9.6A/11.2A. A QC PASS stamp (9) is located to the right of the output specification. The serial number (5) is F0101524V030A0009239, with a barcode below it. The order number (6) is ABC000149 and the country of origin (10) is MADE IN CHINA. At the bottom, there are two warning sections: CAUTION: SEE MANUAL (7) and WARNING: RISK OF HIGH VOLTAGE DO NOT TOUCH UNTIL 4MIN.AFTER POWER OFF (8).

Explanation of the Type Code :

No.		Model:SSI800-4T3R7GB/5R5PB-V00
1-5	SSI800	SSI800 family
6-7	4T	Line in voltage, 4T: 3phase380V 2T: 3phase220V 2S: single phase 220V
8-15	7D5H/011L	Power size. 7D5 means 7.5kw, H means for heavy load type; 011 means 11kw, L means for light load type. For Models not supporting dual rating, digits 12~15 will be null

Note : (“/” and “-” are not counted in the number of digits)

1.1.2 Main specifications and models for SSI800 Power Unit (PU00/PU01)

Model Type	Power (kW)	Voltage (V)	Heavy Load		Light Load		Air (m ³ /h)
			Input (A)	Output (A)	Input (A)	Output (A)	
SSI800-2S0R37GB-PU00	0.37	1×200-240	6.5	2.5	-	-	17.2
SSI800-2S0R75GB-PU00	0.75	1×200-240	9.3	4.5	-	-	17.2
SSI800-2S1R5GB-PU00	1.5	1×200-240	15.5	7.5	-	-	17.2
SSI800-2S2R2GB-PU00	2.2	1×200-240	23	9.6	-	-	45.5
SSI800-2S4R0GB-PU00	4.0	1×200-240	33	16	-	-	90
SSI800-4T0R7GB /1R5GB-PU00	0.75/1.5	3×380-440	3.7	2.3	5.8	3.7	17.2
		3×440-480	3.2	2.1	5.0	3.4	
SSI800-4T1R5GB/2R2PB-PU00	1.5/2.2	3×380-440	6	3.8	8.5	5.3	17.2
		3×440-480	5.2	3.5	7.3	4.8	
SSI800-4T2R2GB/3R7PB -PU00	2.2/4.0	3×380-440	8.5	5.3	14.0	8.5	17.2
		3×440-480	7.3	4.8	12.4	8.2	
SSI800-4T3R7GB/5R5PB -PU00	4.0/5.5	3×380-440	15	9.6	18.6	11.2	45.5
		3×440-480	12.9	8.8	18.1	11.0	
SSI800-4T5R5GB/7R5PB -PU00	5.5/7.5	3×380-440	20.8	13.0	24.7	15.5	90
		3×440-480	19.1	11.8	21.4	14.2	
SSI800-4T7R5GB/011PB -PU00	7.5/11	3×380-440	27.1	17.0	33.1	22.0	90
		3×440-480	23.4	15.5	30.2	21.0	
SSI800-4T011GB/015PB-PU00	11/15	3×380-440	35.9	25.0	42.5	31.0	124
		3×440-480	31.4	22.7	39.8	28.5	
SSI800-4T015GB/018R5PB-PU00	15/18.5	3×380-440	43.4	32.0	50.2	36.0	170
		3×440-480	40.2	29.1	45.8	34.0	
SSI800-4T018R5GB/022PB-PU00	18.5/22	3×380-440	51.5	38.0	58.5	42.5	230
		3×440-480	46.1	34.5	54.0	40.0	
SSI800-4T022GB/030PB-PU00	22/30	3×380-440	61	45.0	79.0	56.0	272
		3×440-480	54.5	40.9	73.0	51.0	
SSI800-4T030G/037P-PU00	30/37	3×380-440	82.5	61.0	98.0	71.0	303
		3×440-480	74	52.0	90.0	65.0	
SSI800-4T037G/045P-PU00	37/45	3×380-440	72	75.0	87.0	90.0	374
		3×440-480	65	68.0	79.0	80.0	
SSI800-4T045G/055P-PU00	45/55	3×380-440	88	91.0	102.0	104	408
		3×440-480	80	82.0	99.0	101	
SSI800-4T055G/075LP-PU00	55/75	3×380-440	110	112	142	145	476
		3×440-480	100	102	132	136	
SSI800-4T075G/090P-PU00	75/90	3×380-440	148	150	170	175	595
		3×440-480	135	140	150	155	
SSI800-4T090G/110P-PU00	90/110	3×380-440	175	180	192	202	646
		3×440-480	155	160	172	179	
SSI800-4T110G/132P-PU00	110/132	3×380-440	206	215	245	255	714
		3×440-480	183	190	225	235	
SSI800-4T132G/160P-PU00	132/160	3×380-440	251	260	290	305	850
		3×440-480	231	240	285	295	
SSI800-4T160H/185L-PU00	160/185	3×380-440	304	315	334	350	1029
		3×440-480	291	302	307	322	
SSI800-4T185G/200P-PU00	185/200	3×380-440	350	365	370	385	1190
		3×440-480	320	335	336	352	
SSI800-4T200G/220P-PU00	200/220	3×380-440	381	395	409	425	1292
		3×440-480	348	361	375	390	
SSI800-4T220G/250P-PU00	220/250	3×380-440	420	435	453	461	1411
		3×440-480	383	398	419	425	
SSI800-4T250G/280P-PU00	250/280	3×380-440	472	480	509	525	1564
		3×440-480	436	443	461	478	
SSI800-4T280G/315P-PU00	280/315	3×380-440	525	540	568	585	1700
		3×440-480	475	490	510	522	
SSI800-4T315G/355P-PU00	315/355	3×380-440	590	605	621	634	1870
		3×440-480	531	540	557	566	
SSI800-4T355G/415P-PU00	355/415	3×380-440	647	660	694	725	2125
		3×440-480	580	590	628	655	
SSI800-4T415G/450P-PU00	415/450	3×380-440	718	745	776	805	2380
		3×440-480	653	678	708	735	

1.1.3 Specification

Item		Specification	
Line in	Voltage	Single Phase 200~240V -15%~+10% ; 3 Phase 380~480V -15%~+10% ;	
	Frequency	50/60Hz±5%	
	Unbalance	3% ;	
Out put	Voltage	3 Phase 0~100% Line in voltage	
	Frequency	0~590Hz ;	
Main Control	Control algorithm	V/F control, Vector Control	
	Motor Type	Induction Motor, PM Motor	
	Start Torque	0.5Hz 150% ;	
	Overload	Heavy load type: 150% 60s, 180% 3s Light load type: 120% 60s, 150% 3s	
	Switching Frequency	0.37~22Kw: 2k~16kHz ; ≥ 30Kw: 2k~12kHz	
	Speed resolution	Digital: 0.001Hz; Analogue: 0.5% of the maximal setup;	
	Speed accuracy at Speed Open Loop	±0.5% of Nominal speed	
	Source of Control Command	Keypad, DI inputs, Bus communication	
	Source of Reference	Keypad, Analogue inputs, Pulse inputs, Bus communication	
Acieration/Deceleration setup	4 sets of acceleration/deceleration time, range: 0.05-6000.00s ;		
Basic Functions	Speed open loop/speed close loop, Process close loop, torque control (with/without speed sensor), Motor auto tuning, Load compensation, auto DC voltage regulation, DC brake/AC brake, speed limit, current/torque limit, fly start, KEB etc. Note: Speed close loop or torque control with speed sensor is OK only when a control unit and PG card are installed		
Application Functions	Multistage speed control by terminals or PLC function, S ramp, Mechanic brake, counter, ProcessPID, Jog etc.		
Protection Functions	Short circuit, Ground fault, line phase loss, under voltage, over voltage, over current, overload, over temperature, motor thermal protection, motor phase loss, control wire broken etc.		
Control Terminals	0.37-7.5KW	DI (Only PU01)	2 Dis for NPN and voltage input
		DO (Only PU01)	1 DO of 40mA
		RS485(Only PU01)	1 RS485/Modbus, maximal 38400bit/s ;
	11-22KW	DI (Only PU01)	3 Dis for NPN and voltage input
		AI (Only PU01)	1AI of Current and Voltage input
		10V (Only PU01)	10V of 10mA
		RL (Only PU01)	1RL for SPST with 3A/250V
		RS485(Only PU01)	1 RS485/Modbus, maximal 38400bit/s ;
Connector	Functions for Control Unit or Keypad		
Operation Environment	Protection Level	IP20 ;	
	Operation Ambient Temperature	Operating range: -10°C ~ 60°C As heavy load type: Nominal current to 50°C, derate from 50°C As light load type: Nominal current to 40°C, derate from 40°C	
	Operation Ambient Humidity	5%-85% (No condensing at 95%) ;	
	Vibration	1.14g ;	
	Altitude	1000m, derate from 1000m	
	Motor cable length	Shielded Cable: 50m ; Un-shielded cable:100m	
Others	Brake Chopper	Built in as default up to 22kW	

1.1.4 Derating requirement

Derating with temperature: when used as heavy load type, derating is required from temperature higher than 50°C. 2.0% per degree is demanded. when used as light load type, derating is required from temperature higher than 40°C. 3.0% per degree is demanded.

Derating with altitude: derating is required from altitude higher than 1000m. 1% load per 100m or 0.5°C ambient temperature is demanded.

1.2 SSI800 Control Unit (CU)

Currently only one type of Control Unit is available. More Control Unit will be available depending on the demands from the market or customization.

1.3 Option cards

AD800 Control Units support different types of option cards, including PG cards, Communication cards and IO extension cards.

1.3.1 Description of name plate

Item	Description
1	Logo
2	Sales number(F0100001) + SW Version(V002) + Production site(A) + SN (0001)+week-year (518)
3	Bar code
4	Company name
5	Type Code
6	QC Pass
7	Certification logo: RoHS CE UL WEEE ed.

Explanation of the Type code :

NO.		Model:AD-PG01
1-2	AD	For SSInverter's drives
3-6		Type of option cards. PG: PG card, DP: ProfiBus-DP card, PN: Profinite card, IO: IO extension card

1.3.2 Main specification and Models of option cards

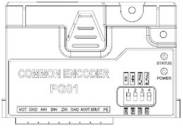
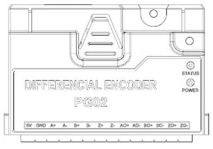
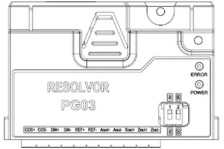
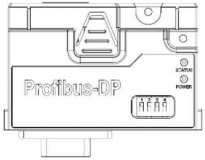
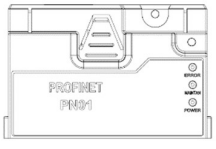
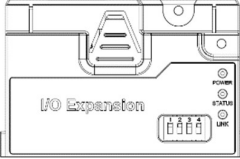
Model type		Main Specification	Appearance
PG card	AD-PG01	Power supply : 12V/24V; 150mA ; Input : A/B/Z, Voltage/OC/OE/push-pull, 50KHz Divider Output : A1 B1 (divider multiple: 1~255)	
	AD-PG02	Power supply : 5V, 200mA ; Input : A+/A-,B+/B-,Z+/Z--differential signal, 200KHZ Divider Output : A+/A-;B+/B- (divider multiple: 1~255)	
	AD-PG03	Resolver Power supply : REF+/REF-; (VRMS : 5V~7V) Stimulation frequency : 10KHZ Inputs: SIN+/SIN-; COS+/COS- Number of pole pair: 2, 4, 6, 8	
Bus communication	AD-DP01	Protocol: Profibus DPV0/DPV1 Terminal: DB9 with DP+, DP-, RTS, 5V, GND Baud rate: 9.6Kbps~12Mbps GSD file: available	
	AD-PN01	Protocol: Profinet RT, IRT, ProfiDrive Terminal: RJ45	
IO extension	AD-IO01	TBD	

1.4 SSI800 Keypad

SSI800 supports two types of keypad: KP01 and KP02 with LED display and LCD display respectively.

1.4.1 Description of the Name plate of keypad

Item	Description
1	Model
2	Sales number(F0100001)+SW version(V002) + Production site(A) + SN(0001) + week-year(518)
3	Bar code
4	QC Pass
5	Certification logo: RoHS CE UL WEEE ed.

Explanation of the type code :

NO.		Model:AD-KP01
1-2	AD	Used for SSI drives
3-6	KP01	Type of the keypad

1.4.2 Main specification and model of keypad

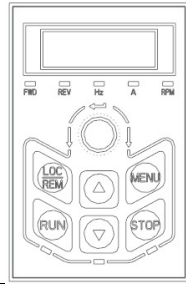
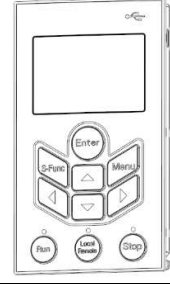
Model Type		AD-KP01	AD-KP02
Main specification	Display	5 digits LED	7 lines LCD, Bilingual
	Remoting distance	15m	15m
	Additional Interface	No	USB, Wi-Fi
	Real Time Clock	No	Yes
Appearance			

1.5 Other options supported in SSI800

Options for din-rail mounting, panel-through mounting and decoupling plate can be afforded for SSI800 application. Din-rail mounting option is only for products up to 2.2Kw. Panel-through mounting options are available only for products from 11Kw to 90Kw. Decoupling plates are available only for products up to 22Kw. In additional, based on the application demands, external chokes, brake resistor or filters could be necessary. The selection of these parts is recommended in this manual. You can buy from a third party, or ask for from us.

1.6 Guidance for use SSI800 modules in combination

1.6.1 Power Units work alone

Both PU00 and PU01 can drive a motor alone.

1.6.1.1 PU00 works alone :

Because there is no DI or RS485 in PU00, the Unit cannot accept the commend from customer or system. Normally PU00 will not be used alone. However, you can connect a keypad, e.g. AD-KP01 to the 10PIN connector and control the motor by the keypad (shown as below picture).

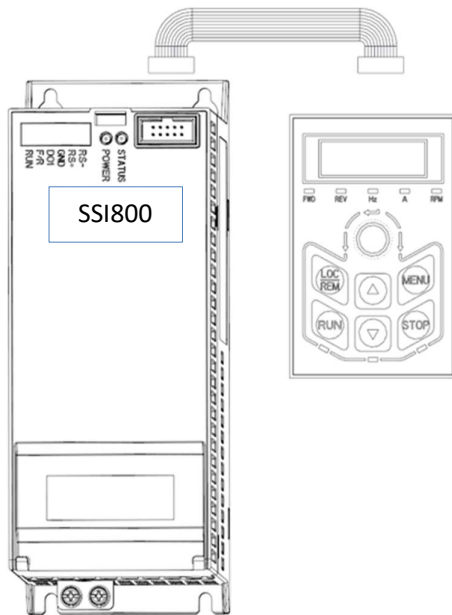

1.6.1.2 PU01 works alone

There are 2 DI, 1 DO and 1 RS485 interface built in PU01, you can send the command to and get feedback from the Power Unit via these terminals with PLC or other controller to achieve the automatic control. At the same time, you can connect a keypad to the Power Unit via the 10 PIN connector (reference to 1.6.1.1)

1.6.2 Combine the Control Unit with Power Unit

To achieve much more complex control than the Power Unit alone, including terminals control, special application and keypad control, you can install a Control Unit onto the Power Unit. You can install the Control Unit onto the Power Unit simply by a “click” or remove the Control Unit from the Power Unit without any special tools, as shown below.

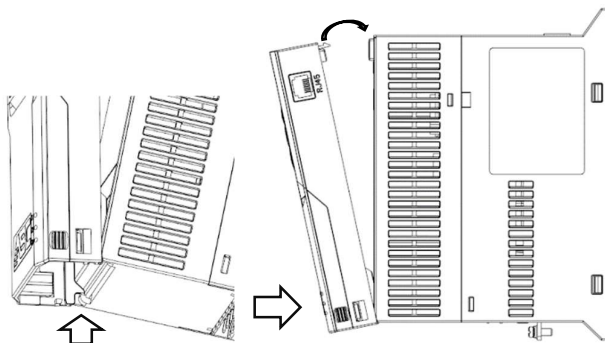

Install the Control Unit onto the Power Unit : Clip the bottom of the Control Unit into the bracket of the Power Unit, then turn the Control Unit to the Power Unit, until a “click” at the top, the installation is finished.

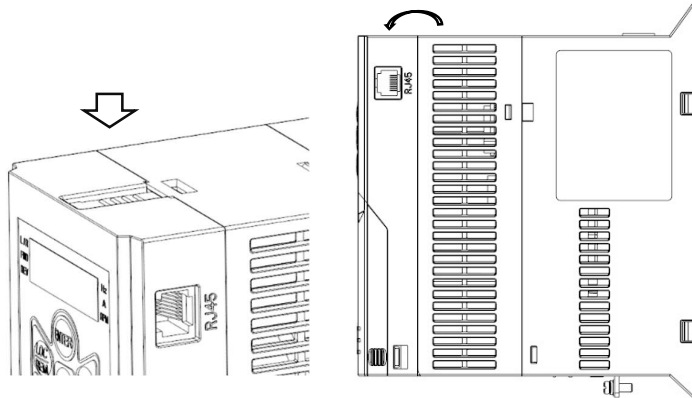

Remove the Control Unit from the Power Unit: Press down the snap joint at the top, then turn and remove the Control Unit from the Power Unit.

The connection between the Control Unit and Power Unit is achieved with special protocol defined by SSI company. For example, when Power Unit PU00 and Control Unit CU00 are combined, then you get a standard frequency converter. The application control speed and terminal scan speed can be 1ms one time and the motor control speed can be 100uS one time fastest. you can set a parameter to define the response from the drive when the Control Unit is removed: alarm or continue to run the motor (default is to alarm and trip to stop). It not recommended to remove or plug the Control Unit while power is on, otherwise the product could be damaged.

Within SSI800 family, any Control Unit is compatible with different Power Units (PU00, PU01 or any future released Power Unit). Specifically, a physically same Control Unit can be installed to different Power Unit and no other set up change is needed. On the other hand, different Control Unit (CU00, CU01 or any future released Control Unit) can be installed to the same Power Unit to achieve different functions or the best performance/cost ratio. You don't need to change any SW or HW setup to achieve these.

1.6.3 Use option card or keypad on Control Unit

You can extend the function by connecting Option Card or Keypad to the Control Unit (CU00, CU01 or other)

Both CU00 and CU01 can support different types of Option Cards, including AD-PG01, AD-PG02, AD-PG03, AD-DP01, AD-PN01, AD-IO01 etc. Only one Option Card can be installed in CU00 at the same time. however, CU01 can support two. How to install the Option Cards into CU00 is shown below.

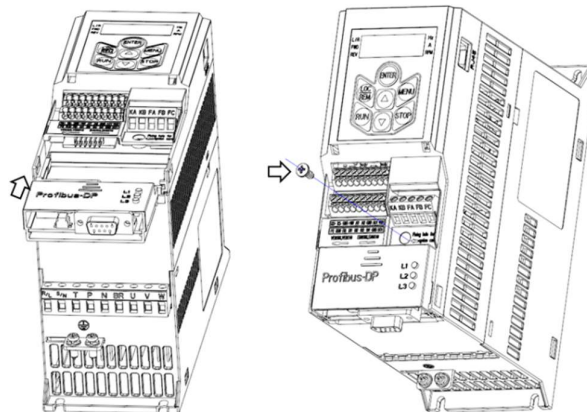

Install the Option Card in CU00: Align the Option Card with the guide rail at the bottom of the Control Unit, then push up to the right position. Fix the Option Card with a screw at the top right corner of the option card.

Although CU00 has an integrated keypad, you can connect an extension keypad (AD-KP01, ADKP02 etc.) via the RJ45 connector. The connection is as below. Please be notified that, if an extension keypad is installed, neither the integrated keypad nor the option card can operate.

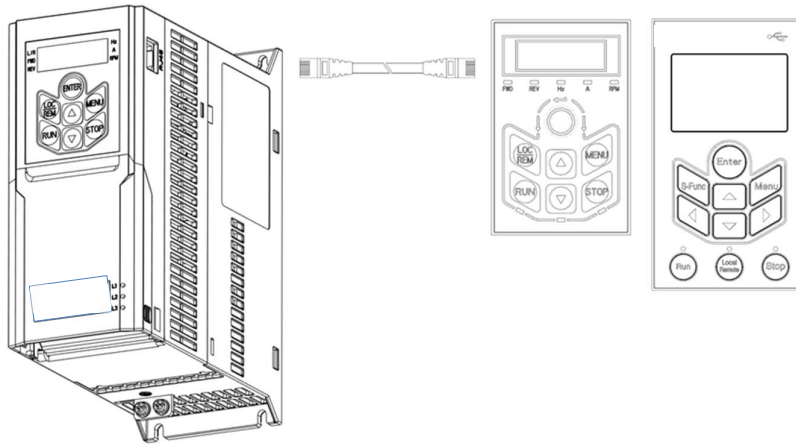

CU01 has no integrated keypad. However, ADKP01 can be installed into CU01 (detachable) or connected to it via a cable. ADKP02 can be connected to CU00 or CU01 only by wire. There is no conflict between Keypad and Option Cards in CU01 for using them at the same time.

Chapter 2 Operation Instruction for SSI800 Power Units

2.1 Safety Instruction for Power Units of SSI800

Definition of Safety :

In the manual, the do's and don'ts of safety announcements are classified into two categories as below:

 Caution: Not following the safety announcements may lead to damage of the product or equipment

 Warning: Not following the safety announcements may lead to death or hurt to the humane body

2.1.1 Before Power On

Caution 

The power supply must be within the specification of product.

Please install the product in a safe environment. Please operate the product within the specified ambient temperature and humidity, avoid direct sunlight to the product. Please prevent the product from dripping water because the protection level of product is IP20. Installing the product in an unsafe environment may lead to fire, explosion or electric shock.

If the product is installed in a cabinet, please ensure a good airconduct. Cooling fans to take the heat out of the cabinet is demanded especially when there are some other components that generates heat. The ambient temperature inside the cabinet should be controlled within specification of all the parts to avoid over temperature protection or fire.

You should NOT RUN/STOP the product by switching on/off the input power to the product, e.g. with a contactor. This operation may lead to damage of the product. Keypad, IO terminal or bus communication command is recommended to run/stop the product.

Installing contactor or air switch at the output side of the product is not recommended. If you have to do so, please make sure that the output current of the product is stopped when operating the contactor or switch.

It is prohibited to connect any capacitor or varistor directly at the output side of the product. Doing so may lead to unexpected failure of damage of the product.

High distortion over the standards in the power supply, including harmonics and unbalance, may lead to failure or damage of the product. Please avoid connecting to the common-connection-point directly with equipment which generate strong distortion in the grid, e.g. electric welding machine.

Make sure all the power ports (R/S/T/P/N/BR/U/V/W) are connected correctly, otherwise the product will be damaged when power on or start.

In factory default set up, motor thermal protection is disabled. If this function is demanded, please set the parameter according to the manual.

Isolation tests to the product or internal components could be destructive and damage the product. Please consult us if you need to do so.

Electronic components is sensitive to ESD, do not touch the PCBAs without ESD protection.

The product is designed for high voltage operation, only qualified electrical engineers can be responsible for the installation, commissioning, tests and maintenance for the product.

Do NOT move the product via the front cover of the product to avoid dropping hazard. Please use the bottom of the product or the specifically designed construction.

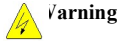

Make sure the power is off for enough time before connecting the wires
Please install the product on fire-proof material to avoid any fire hazard.
Do not install the product in the environment with explosive gases, otherwise there will be explosion hazard.
Connect the PE terminal to the safe ground. NEVER use the null line as ground, otherwise it may lead to electric shock.
It is strictly prohibited to disassemble the products and change the parts, components, connections or setup of the products without permission.
Doing so may lead to electric shock, explosion etc.
Please install the product cover correctly before power on.

2.1.2 With Power on



NEVER plug or remove any part of the product when the product is powered except for the detachable keypad. Doing so may lead to product damage or humane injury or death.
Keep children and irrelevant person away from the product when it is powered on.

2.1.3 Running



Do Not switch in/off the motor to the product during running. Doing so may lead to failure or damage of the product.
Motor cable length exceeding the specification will reduce the life time of the products or lead to failure. If multi-motor is connected to the product, the total motor cable length should be within 50% of the specification. If motor cable length exceeds the limitation, please install filter at the output of the product.
Pay attention to the speed limitation for the motor bearing and other mechanical device.

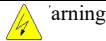

Do NOT touch or detect the circuit with detector of multimeter, oscilloscope or any other equipment.
Do NOT open the front cover of the product during running.
If the Fault-Auto-Restart function is enabled by parameter setup, the motor may rotate again after failure. Please stay away from any moving part including the motor.

2.1.4 Power Off

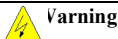

Before touch the power terminals or any part inside the product, please make sure all the connections which can power the product have been removed, including AC line in, DC inputs.
Even all the connections which can power the product have be removed, there could still be residual voltage inside. Please wait for enough time according to the specification before touch the power terminals or any internal parts.

2.2 Mechanical and Electrical Installation

2.2.1 Mechanical Installation

2.2.1.1 Installation Environment

The operation ambient temperature should be within -10°C~60°C;
Install the product on fire-proof material;
Installation vibration should be not higher than 1.14g. Make sure the product is fixed properly to the installation surface;
Ensure enough space around the product for heat dissipation;
Avoid direct sunlight, water dripping, condensing and humidity over limit;
Do NOT install the product in environment with corrosive gas, inflammable gas or explosive gas;
Do NOT install the product in environment with oil contamination, dusty air or metal dust.

2.2.1.2 Outline and Installation Dimensions

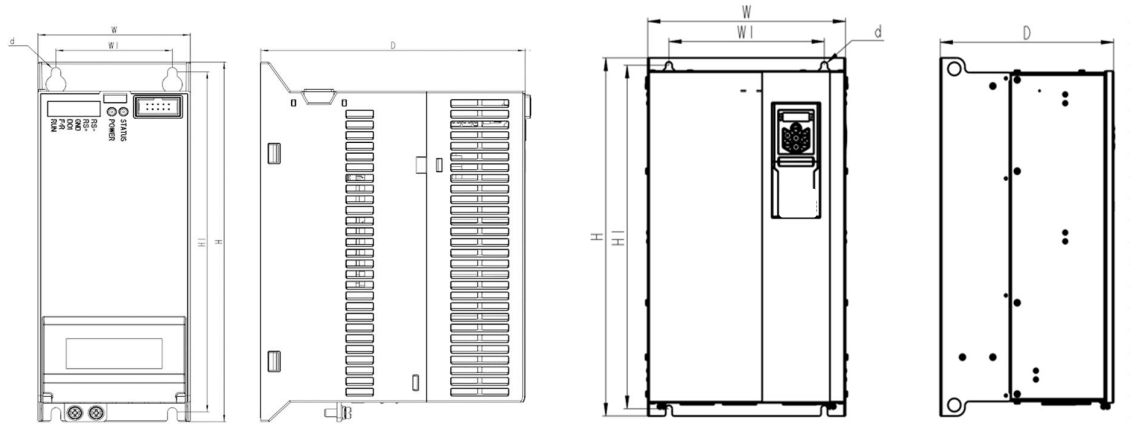

D1-D4 Power unit size

D5-D6 Power Unit/Complete inverter size

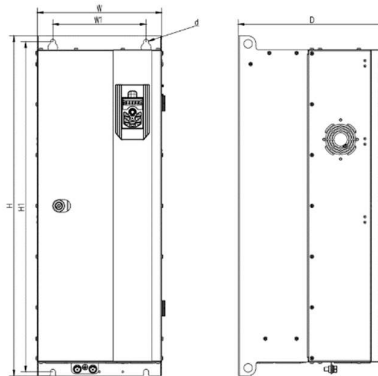

D7-9 Complete inverter size

Frame Sizes:

Frame	Rated Power (Heavy Load Model)		Dimensions (mm)					
	1×200-240V	3×380-480V	W	H	D	W1	H1	d
D1	0.37-1.5kw	0.75-2.2kw	72	185	125	55	175	4.5
D2	2.2kw	4.0kw	88	215	130	70	205	4.5
D3	4.0kw	5.5-7.5kw	100	250	135	80	240	4.5
D4		11-22kw	170	370	150	145	355	6.5
D5		30-45kw	280	490	245.5	220	470	9
D6		55-90kw	330	620	265	270	600	9
D7	-	110-160Kw	320	870	380	240	845	13
D8		185-315Kw	500	1070	410	380	1040	13
D9		355-415Kw	650	1220	430	480	1190	13

2.2.1.3 Product Installation

Single Mounting and Side-by-Side Mounting

SSI800 Power Units support side-by-side mounting as well as single mounting. Enough space around the product should be kept to ensure the heat dissipation, as stated below,

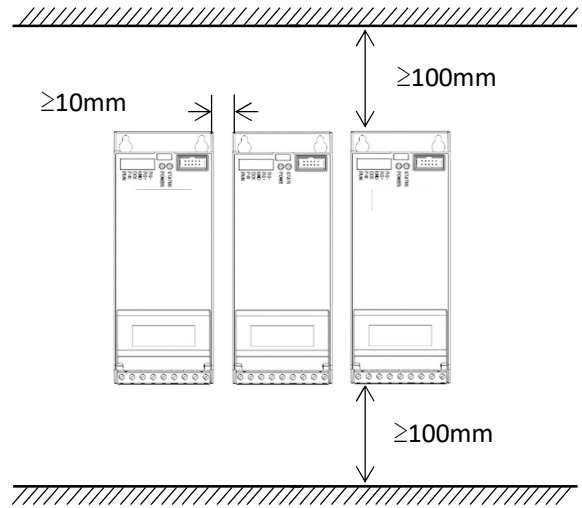

Note: If the demanded space cannot be guaranteed, please reduce the product or lower down the ambient temperature

Above-Underneath Installation

When installing products on top of another, the heat generated by the product underneath could increase the temperature of the product above. In this case a plate for heat isolating and guiding is necessary as shown in the below picture.

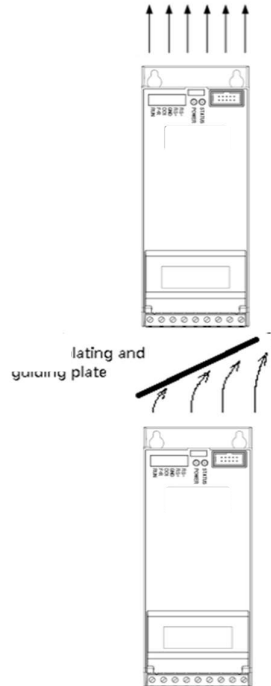

2.2.2 Auxiliary Components Installation

Most possible auxiliary components installed as options for running the product are shown as below:

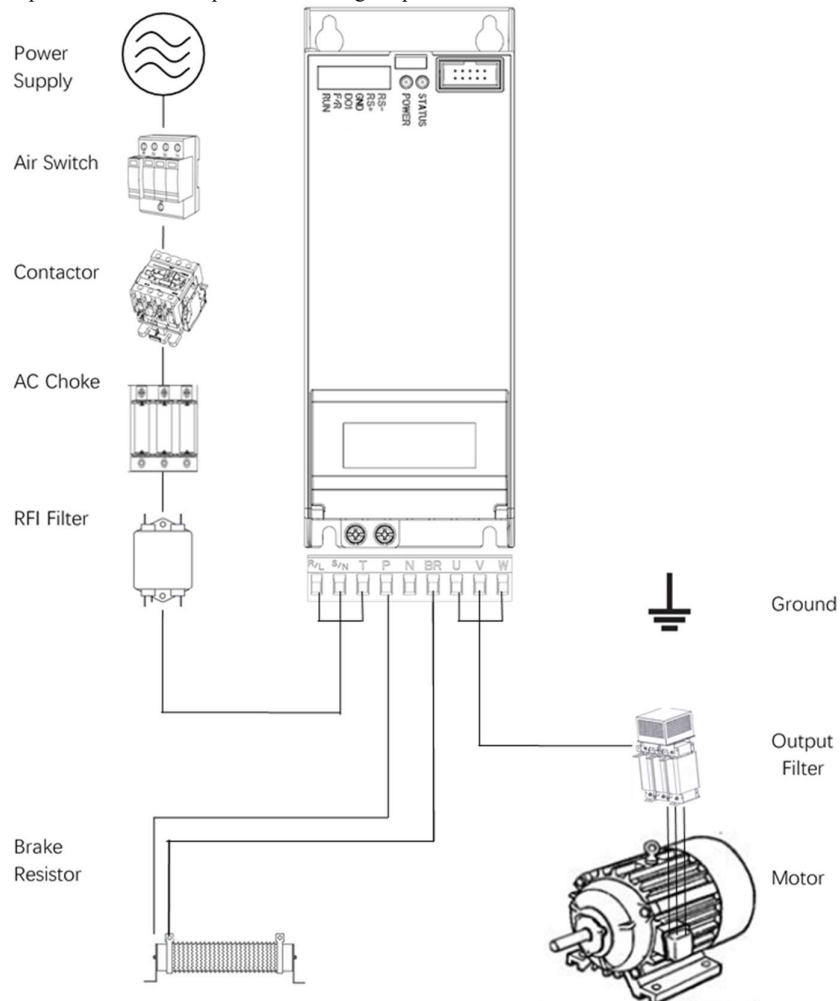

Name	Connect Point	Functions
Air Switch	First to the power supply	Cut the power automatically at high current to protect the product from further damage and limit the failure impact to other equipment
Contactor	Between the air switch and input port	Power on or power off for the product. Please limit the on-off frequency within 2 times per minute, otherwise the product may be damaged. Do NOT run/stop the motor by switching the power with contactor. Doing so may damage the product.
Input Choke	At the input port	To restrain harmonics to the line in current, or to protect the product in harsh grid with voltage distortion or unbalance, AC choke can be connected between the power supply and input port of the product. Please be aware of that AC choke will increase the voltage drop so that reduce the maximal load capacity.
RFI filter	At the input port	In order to achieve higher level of EMC performance especially for conducted emission to the grid, RFI filter should be connected between the power supply and the input port of the product.
Brake Resistor/Brake Chopper	P and BR terminal for Brake Resistor, P and N terminal for Brake Chopper	Brake resistor can be used to consume the electric power generated by the motor when the motor is running at generator mode. For product without integrated brake chopper, external brake chopper should be installed. Please be aware of that, NOT use brake resistor to protect the product at high grid voltage. Energy feedback unit should be used instead of brake resistor in case that the motor will run in generator mode for long duration or high power will be generated.
Output choke, Sine filter	At the output port	Dv/dt choke can be installed to protect the motor from damage by voltage spike in case long motor cable or traditional motor designed for grid direct connection is used. In case of very long motor cable or the motor has specific demands to limit the power loss of harmonic current, sine filter can be used.

2.2.2.1 Selection Guide for air switch, fuse and contactor

Below is the guide for air switch, fuse and contactor:

Product Type Code	Air Switch (A)	Fuse (A)	Contactor (A)
SSI800-2S0R4GB-PU00	10	10	10
SSI800-2S0R7GB-PU00	25	25	16
SSI800-2S1R5GB-PU00	32	32	25
SSI800-2S2R2GB-PU00	40	40	32
SSI800-2S4R0GB-PU00	40	40	32
SSI800-4T0R7GB/1R5PB-PU00	10	10	10
SSI800-4T1R5GB /2R2PB -PU00	10	10	10
SSI800-4T2R2GB /3R7PB -PU00	16	16	10
SSI800-4T3R7GB/5R5PB-PU00	25	25	25
SSI800-4T5R5GB /7R5PB -PU00	32	32	25
SSI800-4T7R5GB /011PB-PU00	40	40	32
SSI800-4T011GB/015PB-PU00	63	63	40
SSI800-4T015GB/018PB-PU00	63	63	63
SSI800-4T018GB/022PB-PU00	100	100	63
SSI800-4T022GB/030PB-PU00	100	100	100
SSI800-4T030G/037P-PU00	150	150	100
SSI800-4T037G/045P-PU00	150	150	100
SSI800-4T045G/055P-PU00	175	175	135
SSI800-4T055G/075P-PU00	200	200	150
SSI800-4T075G/110P-PU00	250	250	200
SSI800-4T090G/110P-PU00	300	300	240
SSI800-4T110G/132P-PU00	350	350	260
SSI800-4T132G/160P-PU00	400	400	350
SSI800-4T160G/185P-PU00	500	500	450
SSI800-4T185G/220P-PU00	630	630	450
SSI800-4T200G/220P-PU00	630	630	550
SSI800-4T220G/250P-PU00	800	800	550
SSI800-4T250G/280P-PU00	800	800	630
SSI800-4T280G/315P-PU00	800	800	630
SSI800-4T315G/355P-PU00	1000	1000	630
SSI800-4T355G/415P-PU00	1000	1000	800
SSI800-4T415G/455P-PU00	1200	1200	800

2.2.2.2 Selection Guide for Brake Resistor

The customer can select brake resistor with resistance and power as calculation below. Basically, the bigger system inertia, shorter deceleration time or more often the motor brakes, the bigger power and smaller resistance of the brake resistor are needed. Please be aware of the the resistance cannot be smaller than the limitation as stated in below table, otherwise the product may be damaged.

Brake resistance selection:

The calculation of brake resistance : $R = U_{DCB}^2 \div (K_{BF} \times P_{Nom})$

U_{DCB} --- the threshold DC voltage triggering the resistor brake function. (This value can be set in the parameter via control keypad or bus communication, normally 385Vdc for 200V product and 710Vdc for 380V product);

P_{Nom} --- The rated power of motor;

K_{BF} --- Brake factor, the bigger inertia, shorter deceleration time, the bigger factor value is needed. K_{BF} value is recommended in range of 0.8~2.0. 1.0 is recommended for general application, 1.5 is recommended for bigger inertia, 2.0 is recommended for steel works equipment;

Selection of brake resistor power

Instant brake power calculation: $P_B = U_{DCB}^2 \div R$

In theory, the power size of the brake resistor can be selected ad instant brake power, but a correction factor should be used based on brake frequency and brake duty to avoid wasting of cost and space. The correction factor is used as: $P_r = K_{Bt} \times P_B$

$K_{Bt} = 0.12 \sim 0.9$ is the correction factor. Normal selection is 0.12, the more frequent in acceleration/deceleration, the longer duration for deceleration, the bigger value of K_{Bt} is needed. Normally for escalator etc., a value of 0.9 is recommended, for Centrifugal equipment a value of 0.6 is recommended. (Please be ware of that the selection of power also depends on the cooling condition.

A recommendation for selection of brake resistor (For applications in which motor work in brake not very frequent and not long duration)

Line in Voltage (V)	Motor Power (kW)	Brake Resistance (Ohm)	Brake Power (W)
1×200-240	0.37	≥200	100
1×200-240	0.75	≥100	200
1×200-240	1.5	≥50	400
1×200-240	2.2	≥35	550
3×380-440	0.75	≥300	200
3×380-440	1.5	≥160	400
3×380-440	2.2	≥100	600
3×380-440	4	≥75	800
3×380-440	5.5	≥50	1200
3×380-440	7.5	≥35	1500
3×380-440	11	≥25	2500
3×380-440	15	≥20	3000
3×380-440	18.5	≥15	3600
3×380-440	22	≥12	5000
3×380-440	30	≥9	7000

2.2.2.3 Selection for input/output AC choke

Selection guide for input AC choke

Line in Voltage (V)	Motor Power (kW)	Choke Current (A)	Choke Inductance (2% voltage drop) (mH)
3 x 200-240	0.37	3.0	2.70
3 x 200-240	0.75	5.0	1.60
3 x 200-240	1.5	7.4	1.10
3 x 200-240	2.2	10.0	0.80
3×380-440	0.75	3.0	4.60
3×380-440	1.5	5.0	2.80
3×380-440	2.2	7.0	2.00
3×380-440	4	10.0	1.40
3×380-440	5.5	15.0	0.93
3×380-440	7.5	20.0	0.70
3×380-440	11	30.0	0.47
3×380-440	15	40.0	0.35
3×380-440	18.5	50.0	0.28
3×380-440	22	60.0	0.24
3×380-440	30	75.0	0.19

Note : a. AC choke is not recommended as a good solution to control the harmonic current

b. It's not recommended to add AC choke at input for products already has built-in choke

Selection guide for output AC choke ($\leq 200\text{m}$ motor cable, $dv/dt < 500\text{v}/\mu\text{S}$)

Line in Voltage (V)	Motor Power (kW)	Choke Current (A)	Choke Inductance /2% voltage drop (mH)
200 - 240	0.37	2.50	3.24
	0.75	4.5	1.80
	1.5	7.50	1.08
	2.2	9.60	0.84
3×380-440	0.75	2.30	6.08
3×380-440	1.5	3.80	3.68
3×380-440	2.2	5.30	2.64
3×380-440	4	9.00	1.56
3×380-440	5.5	13.00	1.08
3×380-440	7.5	17.00	0.82
3×380-440	11	25.00	0.56
3×380-440	15	32.00	0.44
3×380-440	18.5	38.00	0.36
3×380-440	22	45.00	0.32
3×380-440	30	61.00	0.22
3×380-440	37	75	0.18
3×380-440	45	91	0.16
3×380-440	55	112	0.12
3×380-440	75	150	0.10
3×380-440	90	180	0.08
3×380-440	110	215	0.06
3×380-440	132	260	0.06
3×380-440	160	315	0.04
3×380-440	185	365	0.04
3×380-440	200	395	0.04
3×380-440	220	435	0.03
3×380-440	250	480	0.03
3×380-440	280	540	0.03
3×380-440	315	605	0.02
3×380-440	355	660	0.02
3×380-440	415	745	0.02
3×380-440	450	805	0.02

2.2.2.4 Selection for Filters

RFI filter at input

With RFI filter as stated in below table or RFI filter with similar performance installed at the input side of the product, the product can achieve Class A1 EMC performance.

Voltage (V)	Motor Power (kW)	Rated Current for RFI filter (A)	Type of RFI Filter
220V	0.37	5	NFI-0005-SA
	0.75	5	NFI-0005-SA
	1.5	10	NFI-0010-SA
	2.2	10	NFI-0010-SA
380V	0.75	5	NFI-0005-SA
	1.5	5	NFI-0005-SA
	2.2	10	NFI-0010-SA
	4	10	NFI-0010-SA
	5.5	20	NFI-0020-SA
	7.5	20	NFI-0020-SA
	11	36	NFI-0036-SA
	15	36	NFI-0036-SA
	18.5	50	NFI-0050-SA
	22	50	NFI-0050-SA
	30	65	NFI-0065-SA
	37	80	NFI-0080-SA
	45	100	NFI-0100-SA
	55	150	NFI-0150-SA
	75	150	NFI-0150-SA
	90	200	NFI-0200-SA
	110	250	NFI-0250-BA
	132	250	NFI-0250-BA
	160	300	NFI-0300-BA
	185	400	NFI-0400-BA
	200	400	NFI-0400-BA
	220	400	NFI-0400-BA
	250	600	NFI-0600-BA
	280	600	NFI-0600-BA
315	600	NFI-0600-BA	
355	900	NFI-0900-BA	
415	900	NFI-0900-BA	
450	900	NFI-0900-BA	

Note : The RFI filter types are recommended based on products from Shanghai Howcore.

Sine Filter at Output

Below is the recommendation to select sine filter at output.

Voltage (V)	Motor Power (kW)	Rated Current (A)	Inductance (mH)	Capacitance C(uF)
220V	0.37	9	1.60	16.0
	0.75	9	1.60	16.0
	1.5	9	1.60	16.0
	2.2	9	1.60	16.0
380V	0.75	10	2.50	10.0
	1.5	10	2.50	10.0
	2.2	10	2.50	10.0
	4	18	2.50	10.0
	5.5	18	1.50	16.0
	7.5	18	1.50	16.0
	11	30	0.78	32.0
	15	30	0.78	32.0
	18.5	60	0.38	64.0
	22	60	0.38	64.0
	30	60	0.38	64.0
	37	110	0.260	148.0
	45	110	0.260	148.0
	55	110	0.260	148.0
	75	180	0.160	240.0
	90	180	0.160	240.0
	110	270	0.110	350.0
	132	270	0.110	350.0
	160	450	0.066	600.0
	185	450	0.066	600.0
	200	450	0.066	600.0
	220	450	0.066	600.0
	250	750	0.040	1000.0
	280	750	0.040	1000.0
315	750	0.040	1000.0	
355	750	0.040	1000.0	
415	750	0.040	1000.0	

The values (Inductance, Capacitance) are based on sine filter circuit.

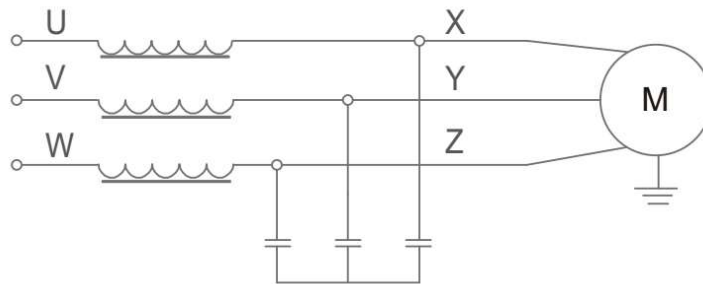

Note : the recommended values are suitable for switching frequency not low than factory default set and motor running frequency not high than 200Hz. If the application conditions are beyond the limit, please update the selection, or consult us

2.2.3 Power Unit PU00/PU01 Electrical Instructions

2.2.3.1 Power Unit PU00/PU01 Electrical Diagram

0.37-7.5KW PU Diagram

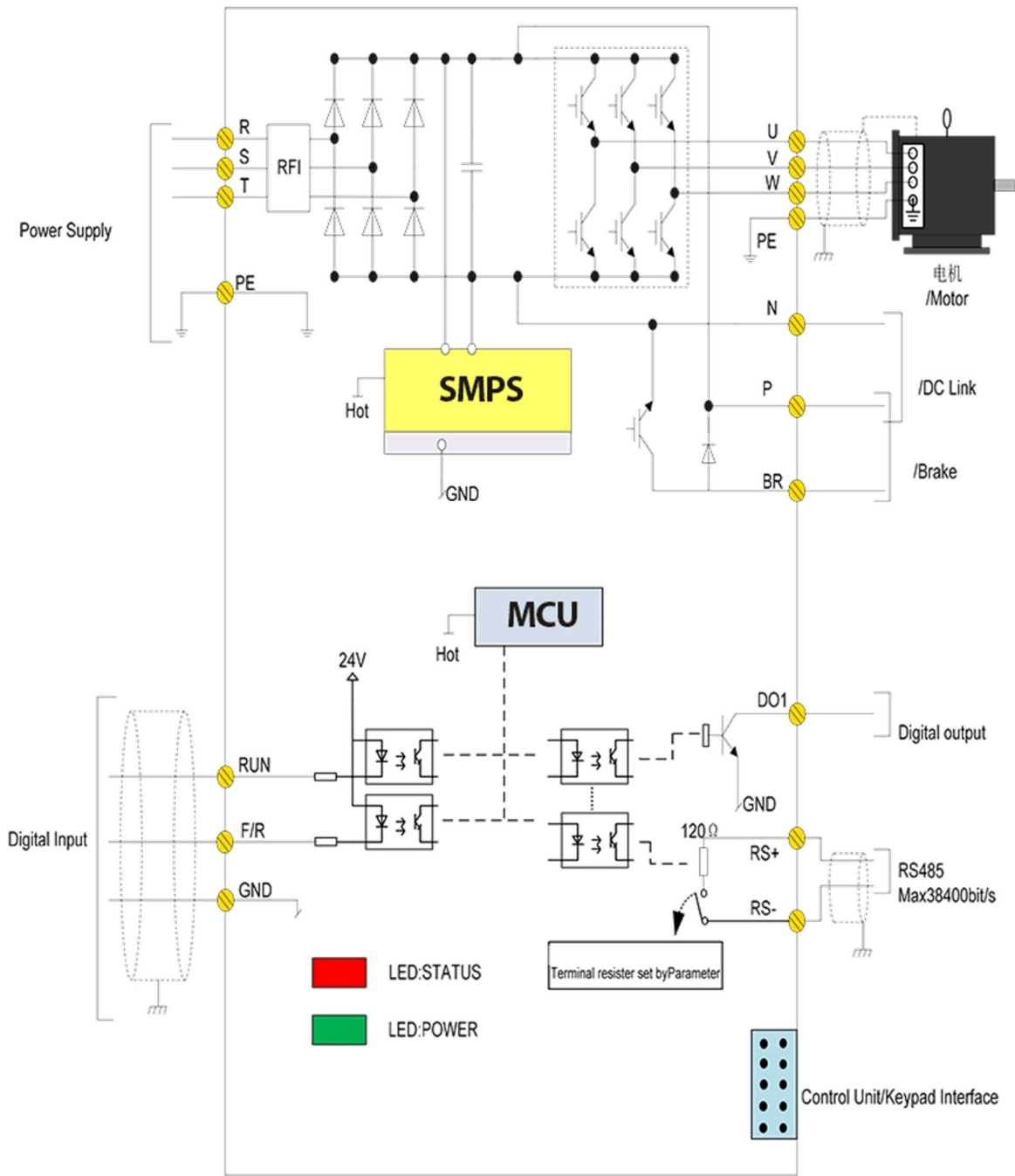

Note: For PU00, there is no terminals for IO Ports (RUN/F/R,DI1,DO1, RS+,RS- and no Status LED lights)

11-22KW PU Diagram

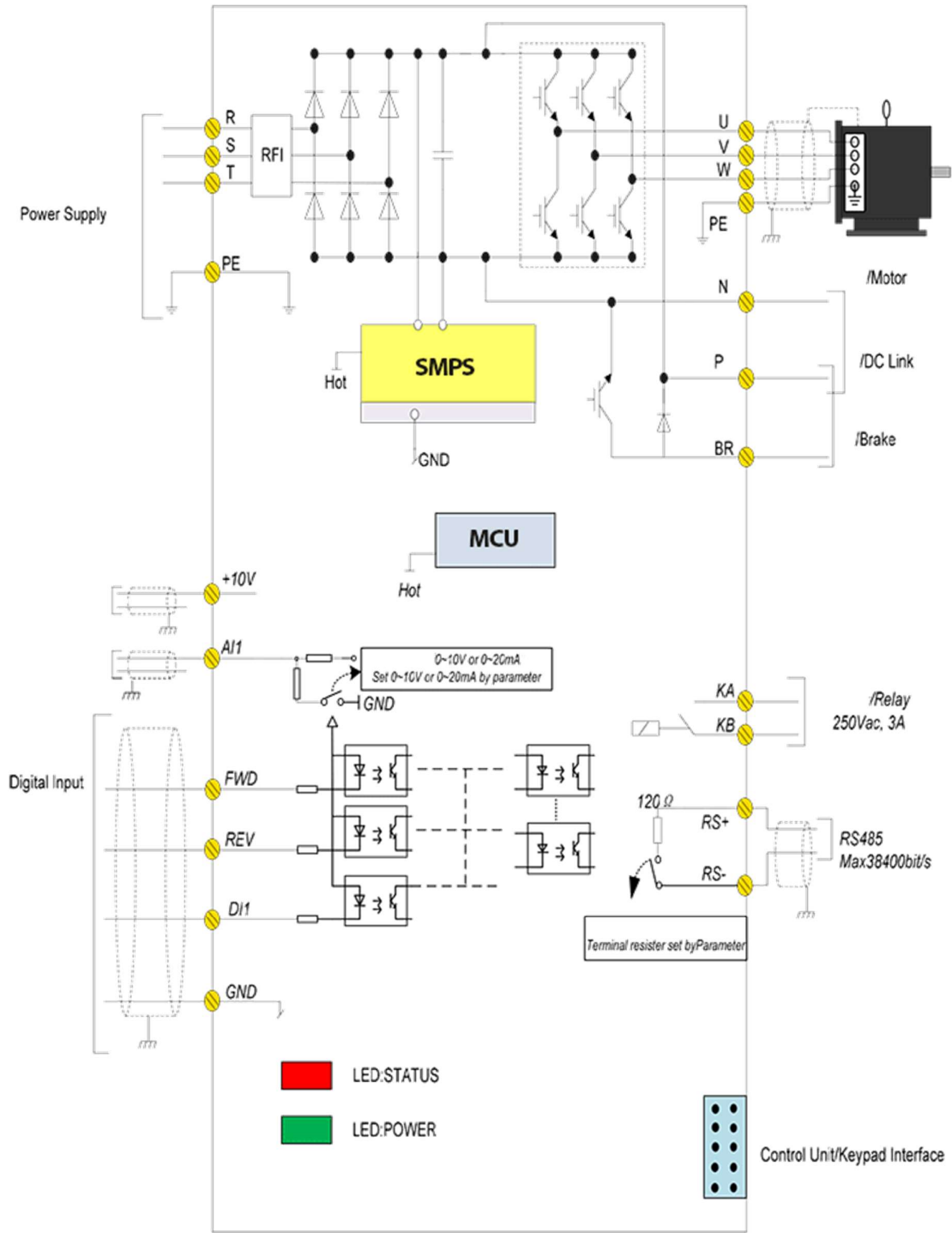

Note: For PU00, there is no terminals for IO Ports (FWD, REV, DI1, AI1, DO1, RS+, RS-, KA/KB) and no Status LED lights.

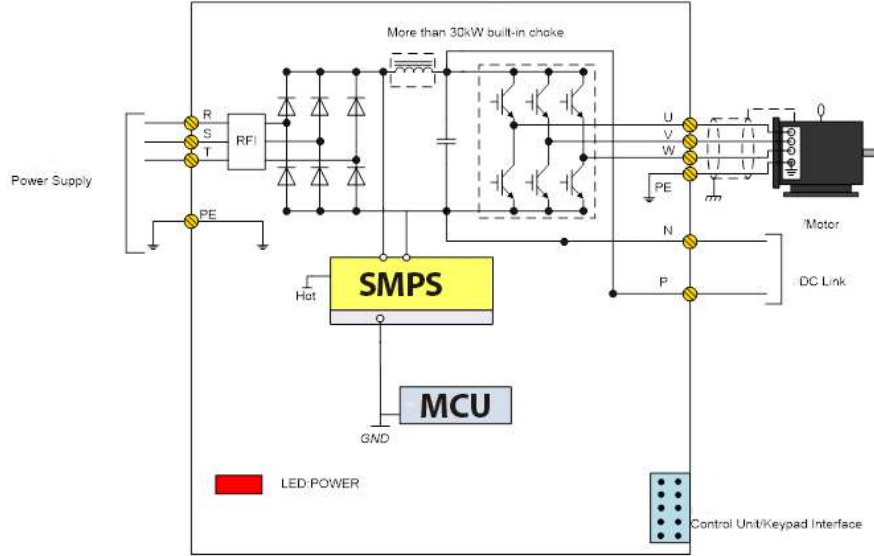
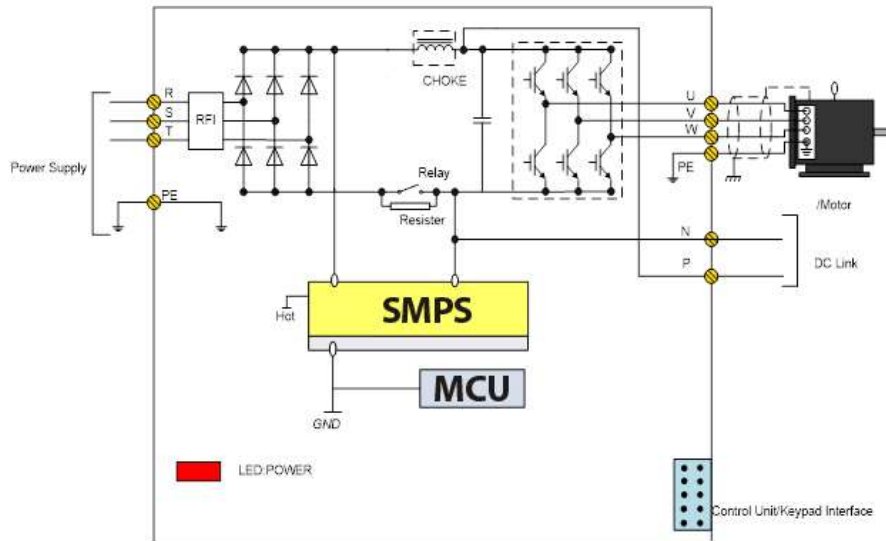
30-90KW PU Diagram

110-450KW PU Diagram

Note: For share Load sharing via DC Bus need to add external choke circuit

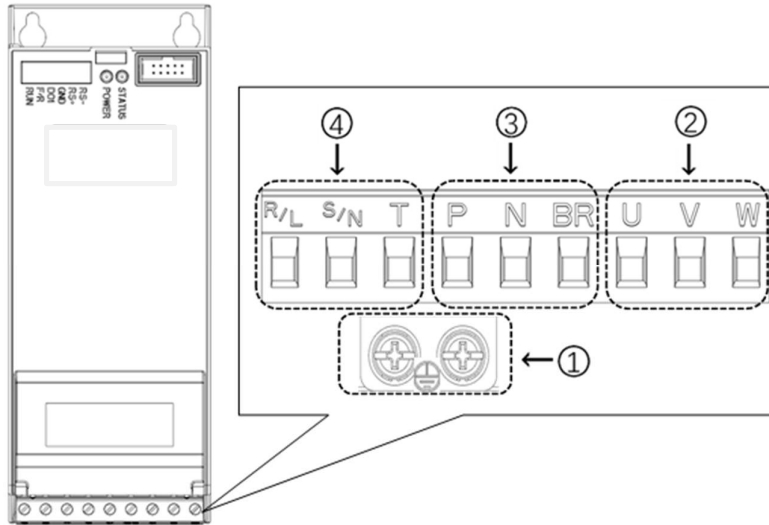
2.2.3.2 Power Unit PU00/PU01 Terminals



Power Terminals for 0.37~7.5Kw

Description for power terminals:

Terminal Name	Terminal Functions
R/L、S/N、T	Terminals for power inputs from grid
U、V、W	Terminals for Power output to motor
P、N	Terminals for DC link supply or Load sharing
P、BR	Terminals for Brake resistor
	For ground connection

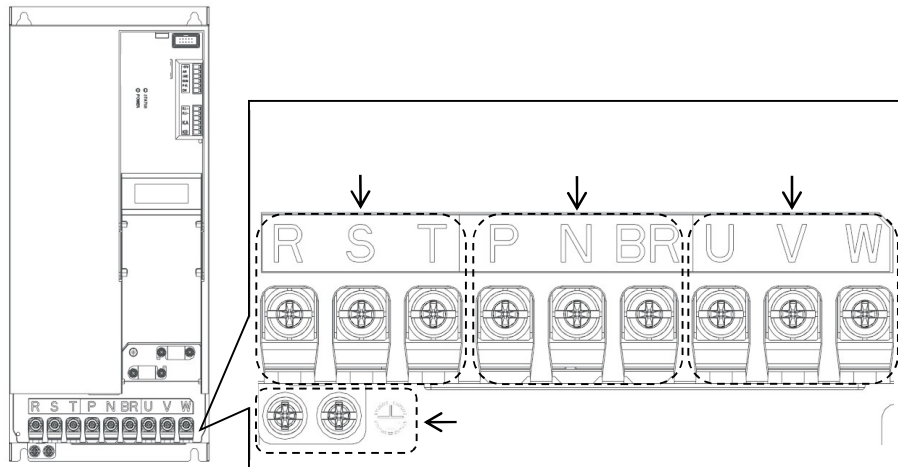

11-22kW Power Terminal

Description for power terminals :

Terminal Name	Terminal Functions
R、S、T	Terminals for power inputs from grid
U、V、W	Terminals for Power output to motor
P、N	Terminals for DC link supply or Load sharing
P、BR	Terminals for Brake resistor
	For ground connection

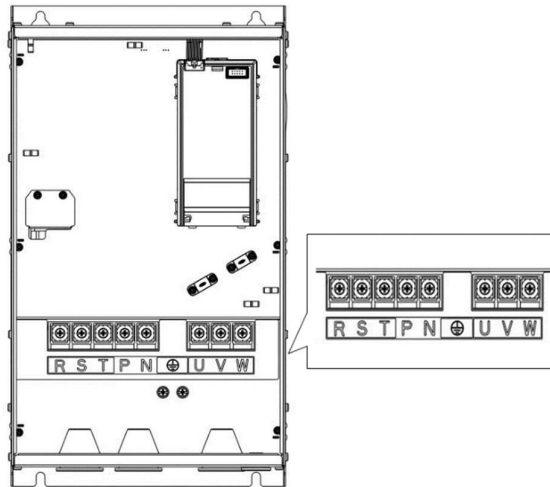

Power terminals for 30-45KW

Description for power terminals :

Terminal Name	Terminal Functions
R、 S、 T	Terminals for power inputs from grid
U、 V、 W	Terminals for Power output to motor
P、 N	Terminals for DC link supply or Load sharing
	For ground connection

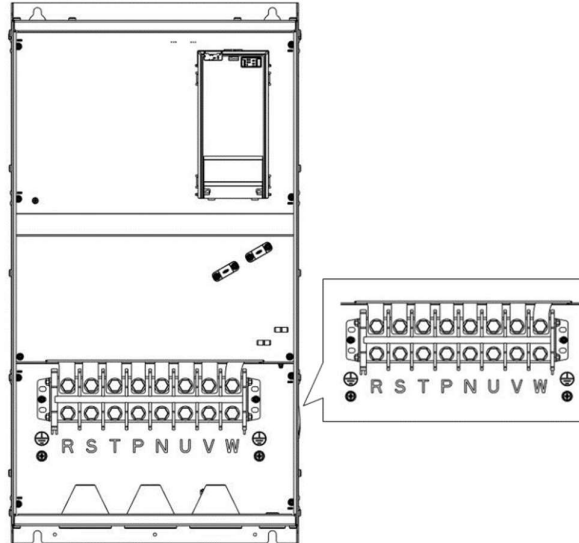

Power terminals of 55Kw -90Kw

Description for power terminals :

Terminal Name	Terminal Functions
R、 S、 T	Terminals for power inputs from grid
U、 V、 W	Terminals for Power output to motor
P、 N	Terminals for DC link supply or Load sharing
	For ground connection

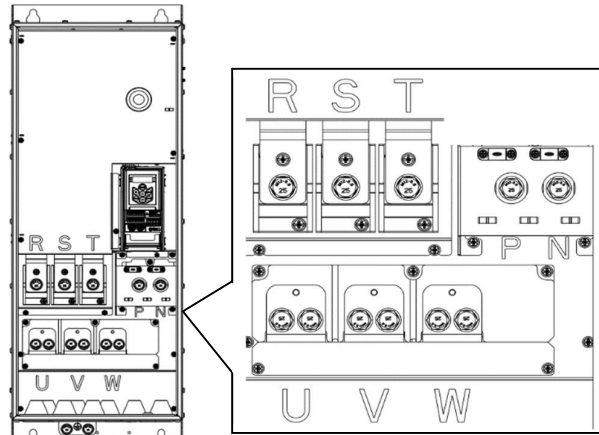

Power terminals of 110Kw -415Kw

Terminal Name	Terminal Functions
R、 S、 T	Terminals for power inputs from grid
U、 V、 W	Terminals for Power output to motor
P、 N	Terminals for DC link supply or Load sharing
	For ground connection

2.2.3.3 Recommended Specifications for Power Circuits installation

Product Type	Input Wire (mm ²)	Output Wire (mm ²)	Power Terminal Screw	Power Terminal Torque (N·m)	Grounding Screw	Grounding Torque (N·m)
SSI800-2S0R4GB-PU00	1	1	M3	0.5-0.7	M4	1.0-1.2
SSI800-2S0R7GB-PU00	1.5	1	M3	0.5-0.7	M4	1.0-1.2
SSI800-2S1R5GB-PU00	1.5	1	M3	0.5-0.7	M4	1.0-1.2
SSI800-2S2R2GB-PU00	2.5	1.5	M3	0.5-0.7	M4	1.0-1.2
SSI800-2S4R0GB-PU00	2.5	1.5	M3	0.5-0.7	M4	1.0-1.2
SSI800-4T0R7GB/1R5PB-PU00	1	1	M3	0.5-0.7	M4	1.0-1.2
SSI800-4T1R5GB /2R2PB -PU00	1	1	M3	0.5-0.7	M4	1.0-1.2
SSI800-4T2R2GB /3R7PB -PU00	1	1	M3	0.5-0.7	M4	1.0-1.2
SSI800-4T3R7GB/5R5PB-PU00	1.5	1.5	M3	0.5-0.7	M4	1.0-1.2
SSI800-4T5R5GB /7R5PB -PU00	1.5	1.5	M3	0.5-0.7	M4	1.0-1.2
SSI800-4T7R5GB /011PB-PU00	2.5	1.5	M3	0.5-0.7	M4	1.0-1.2
SSI800-4T011GB/015PB-PU00	4	2.5	M5	1.6-2.0	M5	1.6-2.0
SSI800-4T015GB/018PB-PU00	6	4	M5	1.6-2.0	M5	1.6-2.0
SSI800-4T018GB/022PB-PU00	10	4	M5	1.6-2.0	M5	1.6-2.0
SSI800-4T022GB/030PB-PU00	10	6	M5	1.6-2.0	M5	1.6-2.0
SSI800-4T030G/037P-PU00	10	6	M5	1.6-2.0	M5	1.6-2.0
SSI800-4T037G/045P-PU00	10	10	M6	2.0-2.5	M6	2.0-2.5
SSI800-4T045G/055P-PU00	16	16	M6	2.0-2.5	M6	2.0-2.5
SSI800-4T055G/075P-PU00	16	16	M6	2.0-2.5	M6	2.0-2.5
SSI800-4T075G/110P-PU00	25	25	M8	8-10	M6	2.0-2.5
SSI800-4T090G/110P-PU00	35	35	M8	8-10	M6	2.0-2.5
SSI800-4T110G/132P-PU00	70	70	M8	8-10	M6	2.0-2.5
SSI800-4T132G/160P-PU00	95	95	InputM12Output M10*2	Input20-25 Output12-16	2*M10	12-16
SSI800-4T160G/185P-PU00	120	120	InputM12 Output2*M10	Input20-25 Output12-16	2*M10	12-16
SSI800-4T185G/220P-PU00	150	150	InputM12 Output2*M10	Input20-25 Output12-16	2*M10	12-16
SSI800-4T200G/220P-PU00	2*70	2*70	2*M12	30-38	2*M10	12-16
SSI800-4T220G/250P-PU00	2*95	2*95	2*M12	30-38	2*M10	12-16
SSI800-4T250G/280P-PU00	2*95	2*95	2*M12	30-38	2*M10	12-16
SSI800-4T280G/315P-PU00	2*120	2*120	2*M12	30-38	2*M10	12-16
SSI800-4T315G/355P-PU00	2*120	2*120	2*M12	30-38	2*M10	12-16
SSI800-4T355G/415P-PU00	2*150	2*150	2*M12	30-38	2*M10	12-16
SSI800-4T415G/455P-PU00	2*185	2*185	2*M12	30-38	2*M10	12-16

Note: The recommended specification's are based on 25°C ambient and VV type single conductor wire. Please reference to the IEC standards for other conditions.

2.2.3.4 Guidance for Selection of Residual-Current Circuit Breaker

When install residual-current circuit breaker between the power supply and product's input (R/L,S/N,T), please consider the leakage current at normal operation. With the product running, leakage current can be generated from sources as below, even there is nothing abnormal:

Due to parasitic capacitance between motor cable and ground, as well as between motor winding and motor case, generated by PWM output from the product.

Due to the unbalance of the grid power supply or the tolerance of the RFI capacitors, there could be residual current going through the grounding capacitors.

For application with frequency converter, special residual-current circuit breaker should be applied, as suggested below:

Specialized circuit breaker (only sensing current of low frequency) with rated residual current higher than 10mA

If normal circuit breaker is selected, the rated residual current should be higher than 200mA and response time should be more than 0.1 second.

2.2.3.5 PU01 Control Terminals

0.37-7.5KW PU01 Control terminals

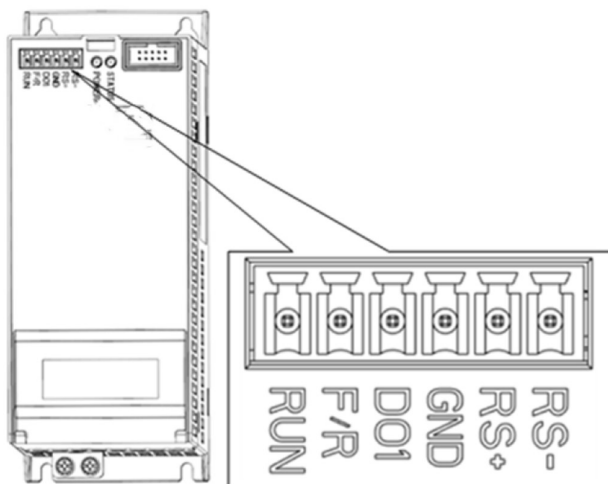

Specifications of Control Terminals 0.37-7.5kw of PU01:

Name	Function	Specification
RS+, RS-	RS485 communication	Max Bit Rate: 38400bit/s ; Configurable termination resistor (default: open)
RUN, F/R	Digital Input	1. Input Type: NPN 2. Input Impedance : 3.6kΩ ; 3. Voltage range: 0-30V ;
DO1	Digital Output	1. Output mode: Open Collector; 2. Output current: max 40Ma;
GND	Signal Gnd	Grounding for both digital and analogue signals

11-22KW Control Terminals of PU01:

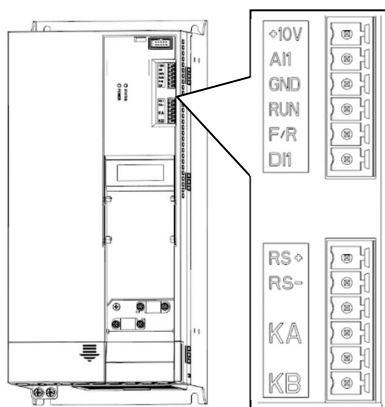

Specifications of Control Terminals 11-22kw of PU01:

Name	Function	Specification
RS+, RS-	RS485 communication	Max Baud Rate: 38400bit/s; Configurable termination resistor, open in default
RUN, F/R, DI1	Digital Input	1. Input type NPN and PNP
		2. Input Impedance : 3.6kΩ ;
		3. Input Voltage : 0-30V ;
AI1	Analogue input	Configurable as analogue voltage inputs, analogue current inputs as well as digital inputs. 1. As Analogue Voltage Inputs: Input Impedance: 10kΩ; Input Voltage Range: 0~10V; 2. As Analogue Current Inputs: Input Impedance: ≤500Ω; Input Current Range: 0~20mA;
+10V	10V signal power supply	Max 10mA
KA-KB	Relay output	Resistive Load: 250VAC 3A/30VDC 3A ; Inductive Load: 250VAC 0.2A/24VDC 0.1A (cosφ=0.4) ;
GND	Signal Ground	

2.2.4 EMC Guidance for Electrical Wiring
2.2.4.1 EMC Standards

SSI800 follow the IEC standards: IEC/EN61800-3 (Adjustable speed electrical power drive systems part 3:EMC requirements and specific test methods).

IEC/EN61800-3 defines the EMC demands from two aspects: EMC interference and EMC immunity. EMC interference includes radiated emission, conducted emission and low frequency current emission. EMC immunity includes radiated immunity, conducted immunity, surge, burst, ESD and immunity to low frequency disturbance from the grid power supply (voltage dips, notch, sag and fluctuation, unbalance, distortion and frequency variation). SSI800 follow all the demands except for:

External AC choke is needed to achieve IEC 61000-3-2/IEC 61000-3-12 for drives below 30kW (refer to 2.2.2.3)

External RFI filter is needed to achieve class C1 or C2 (IEC 61800-3) level conducted emission performance (refer to 2.2.2.4). If no external RFI filter is installed, SSI800 is not intended to be used on a low-voltage public network which supplies domestic premises directly.

2.2.4.2 Guidance for EMC Noise Handling

While used on a common supply with other equipment, even though an RFI filter is built in SSI800 already too limited the conducted emission, depending on the sensitivity of equipment and the background of the environment, there is still certain possibility to disturb other equipment to malfunction. Below measures are recommended to avoid the EMC issue:

Install an RFI filter before the product

Install a power filter before the equipment sensitive to EMC noise

Isolate the power supply for the product from the equipment sensitive to EMC noise, normally with isolation transformer.

Use shielded wire for control signals and shielded cable for motor, ground the shielding properly

Avoid wiring the control signals in parallel with power circuits, especially, avoid tiring the control wires together with the power cables. If a cross between control wire and power cable cannot be avoided, please cross the wires perpendicularly.

If no reliable grounding point or no shielded motor cable available, please use an additional wire to connect the motor shell to the PE terminal and layout this wire together with the 3 motor phases as close and tight as possible.

Installing ferrite cores at the input or the output of the product as common choke helps a lot to solve the EMC issue in most cases.

2.2.4.3 Leakage Current Handling

As stated in 2.2.3.4, there are different reasons for leakage current. The leakage current issue should be handled properly to avoid any mis operation of the residual-current circuit breaker or interference to other equipment. Below are the recommendations:

Lower the switching frequency and use as short as possible motor cable to limit the high frequency leakage current;

Install AC choke or sine filter at the output of the product;

Take measures to limit the unbalance of the power supply.

2.2.4.4 Handling the Induced Voltage

In case there is no grounding point, there could be induced voltage on the motor shell or other metals connected to the motor shell. Connecting the motor shell to the PE terminal of the product helps to limit the induced voltage. But please be aware that, the only safe way is to ground the motor and product properly.

2.2.4.5 Grounding

Please ground the system as blow:

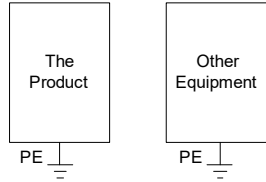

Use thick wire for ground to reduce the grounding impedance;

Use as short as possible grounding wire;

Grounding the product to the ground point as close as possible;

Use four-wire motor cable, and connect the motor shell to the PE terminal of the product with one of the four wires, and grounding this wire to the dedicated grounding point;

Put the grounding wires far away from the input/outputs of the equipment which are sensitive to EMC Noise.

2.3 List of Parameters

Parameter Number	Parameter Name	Value Range	Unit	Factory Default
Parameter Group 0 : General Control Mode and Commands				
P0-01	Control Mode	0: Speed Mode Speed Sensor less 1: Speed Mode with Speed Sensor 2: Torque Mode Speed Sensor less 3: Torque Mode with Speed Sensor		0
*P0-02	Motor Control Principle	0: V/F 1: Vector Control 1 2: Vector Control 2		1
*P0-04	Torque Characteristics	0 : CT 1 : VT 9 : AEO		0
*P0-05	Motor Speed Direction	0 : Clockwise 1 : Anticlockwise 2 : Bidirectional		2
*P0-06	Dual Rating Selection	0: Heavy Load 1: Light Load		0
P0-10	Speed Set Source Selection	0~5		0
P0-11	Main Set Source	0~30		1
P0-12	Additional Set Source	Same as P0-11		20
P0-13	Torque Set Source for Torque Mode	Same as P0-11		1
P0-14	Set Value Calculation from Main and Additional Source	0 : Main Set Source + Additional Set Source 1 : Main Set Source - Additional Set Source 2 : Maximal Value of Main and Additional Set Source 3 : Minimal Value of Main and Additional Set Source		0
P0-15	Speed Set Range	0 : 0~P0-16 1 : -P0-16~P0-16		0
P0-16	Base Value for Speed Set	0.0~590.0		50.0
P0-17	Control Site	0 : Terminal or Bus Communication 1 : Terminal 2 : Bus Communication		0
P0-18	Selection of Communication Control Source	0 : Null 1 : Local RS485 2 : Bus from Option Card		1
P0-30~P0-45	Multi Preset Values	-100.00~100.00	%	0.00
P0-46	UP/DOWN Step Value	0.01~50.00		0.10
P0-47	Save Up/Down Set Value	0 : Not Save 1 : Save when Stop 2 : Save when Power Down		0
P0-48	Jog Speed	0.0~400.0HZ	Hz	5.0

P0-49	Ramp Time Resolution	0 : 0.1s 1 : 0.01s		1
P0-50	Ramp 1 Type	0 : Linear 1 : S ramp		0
P0-51	Ramp 1 Ramp Up Time	0.05~655.35	s	*
P0-52	Ramp 1 Ramp Down Time	0.05~655.35	s	*
P0-53	Ramp 2 Type	0 : Linear 1 : S ramp		0
P0-54	Ramp 2 Ramp Up Time	0.05~655.35	s	*
P0-55	Ramp 2 Ramp Down Time	0.05~655.35	s	*
P0-56	Ramp 3 Type	0 : Linear 1 : S ramp		0
P0-57	Ramp 3 Ramp Up Time	0.05~655.35	s	*
P0-58	Ramp 3 Ramp Down Time	0.05~655.35	s	*
P0-59	Ramp 4 Type	0 : Linear 1 : S ramp		0
P0-60	Ramp 4 Ramp Up Time	0.05~655.35	s	*
P0-61	Ramp 4 Ramp Down Time	0.05~655.35	s	*
P0-62	Jog Ramp Time	0.05~655.35	s	*
P0-63	S Ramp Up Initiate Period	0.05~655.35	s	*
P0-64	S Ramp Up Termination Period	0.05~655.35	s	*
P0-65	S Ramp Down Initiate Period	0.05~655.35	s	*
P0-66	S Ramp Down Termination Period	0.05~655.35	s	*
P0-80	Local Address	1~127		1
P0-81	Baud Rate	0 : 2400 1 : 4800 2 : 9600 3 : 19200 4 : 38400 5~9 : Reserved		2
P0-82	Communication Data Format (Parity/Stop Bits)	0 : Even parity (1 stop bit) 1 : Odd parity (1 stop bit) 2 : No parity (1 stop bit) 3 : No parity (2 stop bit)		0
P0-83	Min. Communication Response Delay	0.000~0.500	s	0.002
P0-84	Max. Communication Response Delay	0.010~10.000	s	5.000
P0-85	Message Response	0 : Normal Responses 1 : Only Response Exceptional Message 2 : Not Response		0
P0-86	Parameter (Set by Communication) Saving at Power Down	0 : Not Save Parameter at Power Down 1 : Save Parameter at Power Down		0
P0-87	Communication terminal resistance selection	0 : Open 1 : Close		0
P0-88	Communication Timeout Time	0.01~650.00	s	1.00
P0-89	Communication Timeout Response Function	0 : No Function 2 : Stop Motor 3 : Jogging 4 : Run with Max Frequency P5-03 5 : Alarm Fault and Trip to stop 6 : Warning		0
P0-90	Reset Communication Timeout	0 : No Action 1 : Reset the Timeout		0
Parameter Group 1 : Basics for Inverter and Motor Control				
P1-00	Switching Frequency	2~16 : 2~16 kHz		*
*P1-01	Grid Type	2~122		*
*P1-02	Motor Type	0 : Induction Motor 1 : SPM 2 : IPM without Saturation 3 : IPM with Saturation		0
*P1-03	Rated Motor Power	0.12~450	kW	*
*P1-04	Rated Motor Voltage	50~1000	V	*
*P1-05	Rated Motor Frequency	20~400	Hz	*
*P1-06	Rated Motor Current	0.1~1200	A	*
*P1-07	Rated Motor Speed	100~24000	rpm	*

*P1-08	Rated Motor Torque	0.1~6553.5	N·m	*
*P1-13	Autotuning for Motor Parameters	0 : No Function 1 : Simple Static Motor Auto Tuning 2 : Complete Static Motor Auto Tuning 3 : Complete Static Motor Auto Tuning + Spinning BEMF (PM) 4 : Complete Static Motor Auto Tuning + Spinning Inertia (PM) 5 : Complete Static Motor Auto Tuning + Spinning BEMF (PM) + Spinning Inertia (PM)		0
*P1-14	Stator Resistance (Rs)	0.001~65.535	Ω	*
*P1-15	Rotor Resistance (Rr)	0.001~65.535	Ω	*
*P1-16	Stator Leakage Reactance (Xl)	0.001~65.535	Ω	*
*P1-17	Main Reactance (Xh)	0.01~655.35	Ω	*
*P1-18	Ld, PM D-axis Inductance	0.01~655.35	mH	*
*P1-19	Lq, PM Q-axis Inductance	0.01~655.35	mH	*
*P1-20	Ld-s, PM D-axis Inductance Saturated	0.01~655.35	mH	*
*P1-21	Lq-s, PM Q-axis Inductance Saturated	0.01~655.35	mH	*
*P1-22	Saturation Current at D-axis for Ld-s	20~200	%	100
*P1-23	Saturation Current at Q-axis for Lq-s	20~200	%	100
*P1-24	Number of Motor Poles	2~100	P	4
*P1-25	BEMF at Rated Speed for PM	0~9000	V	*
*P1-26	Motor Cable Length	0~150	m	10
*P1-27	System Inertia	0.00~655.35	kg·m ²	*
P1-32	Load Compensation Gain for Low Speed	0~199	%	100
P1-33	Load Compensation Gain for High Speed	0~199	%	100
P1-34	Motor Magnet Current at 0 Speed	0~300	%	100
P1-35	Cut in Speed for Normal Magnet Current	0.0~10.0	Hz	0.0
P1-36	Min Motor Current at Low Speed	0~120	%	80
P1-37	Slip Compensation Gain	-400~399	%	*
P1-38	Slip Compensation Time Constant	0.05~5.00	s	*
P1-39	Resonance Damping Gain	0~3000	%	*
P1-40	Time Constant for Resonance Damping Filter	0.005~0.050	s	0.005
P1-41	Damping Coefficient for PM	0~250	%	120
P1-42	Damping Time Constant for Low Speed range (PM)	0.01~20.00	s	0.8
P1-43	Damping Time Constant for High Speed range (PM)	0.01~20.00	s	0.8
P1-44	Time Constant for Current Filter (PM)	0.001~1.000	s	0.5
P1-45	Min Torque at Torque Mode Start	-100~100	%	5
P1-46	Min Torque Cut Out Speed at Torque Mode Start	0.1~50.0	Hz	3.0
P1-53/P1-55/P1-57/P1-59/P1-61	Voltage for V/F curve points	0.0~999.9	V	*
P1-54/P1-56/P1-58/P1-60/P1-62	Frequency for V/F curve Points	0.0~590.0	Hz	*
P1-63	PM Start Method	0 : Initial Position Detection (IPD) 1 : Parking		1
*P1-64	IM Start Method	0 : Direct Start 1 : Fly start		0
P1-67	Min Valid Speed Set	0.00~50.00	Hz	0.00
P1-68	Bypass Range for IM Low Speed	0.0~20.0	Hz	0.0
P1-70	Delay Time at Start	0.0~10.0	s	0.0
P1-71	Delay Function at Start	0 : Free Coast 1 : DC Hold		0
P1-72	DC Hold Current	0~150	%	50
P1-79	Stop Method at Torque Control Mode	0 : Stop with Torque Mode 1 : Stop with Speed Mode		0
P1-80	Function at Stop	0 : Free Coast 1 : DC hold		0
P1-81	Cut in Speed for Function at Stop	0.0~400.0	Hz	0.0
P1-82	DC Brake Current (IM)	0~150	%	50
P1-83	DC Brake Time (IM)	0.0~60.0	s	2
P1-84	DC Brake Cut in Speed (IM)	0.0~400.0	Hz	0.0
P1-85	Demagnetizing Rate at DC Cut in	0~100	%	100
P1-86	Parking Current (PM Start)	0~150	%	80

P1-87	Parking Time (PM Start)	0.1~60.0	s	3.0
P1-91	Brake Function	0 : No Function 1 : Resistor Brake 2 : AC Brake		0
P1-92	Max AC Brake Current	0~150	%	100
P1-93	AC Brake Gain	1.0~2.0		1.4
P1-94	Threshold Voltage for Brake Function	Grid Dependent	V	*
P1-95	Resistor Brake Resistance	5~65535	Ω	*
Parameter Group 2: Digital Terminal Functions				
P2-00	DI Positive-Negative Logic Selection	0~65535		0
P2-01	DO/Relay Positive-Negative Logic Selection	0~65535		0
P2-02	DI Input Mode	0 : NPN Input 1 : PNP Input		0
P2-04	DI Filter time	2~16	ms	4
P2-05	DI Function Selection - Terminal RUN			10
P2-06	DI Function Selection - Terminal F/R	0 : No Function		11
P2-07	DI Function Selection - Terminal D1	1 : Reset		22
P2-08	DI Function Selection - Terminal D2	2 : Coast to Stop (Negative Logic)		23
P2-09	DI Function Selection - Terminal D3	3 : Coast to Stop and Reset (Negative Logic)		24
P2-10	DI Function Selection - Terminal D4	4 : Stop (Negative Logic) 10 : Run 11 : Forward/Reverse Selection 12 : Run in Reverse Direction 13 : Latched run forward 14 : Latched run reverse 15 : Forward Jog 16 : Reverse Jog 20 : Forbid Forward 21 : Forbid Reverse 22 : Preset Value Command Bit 1 23 : Preset Value Command Bit 2 24 : Preset Value Command Bit 3 25 : Preset Value Command Bit 4 26 : Ramp Time Selection Bit 1 27 : Ramp Time Selection Bit 2 30 : Speed UP 31 : Speed DOWN 32 : Counter A 34 : Reset Counter A 35 : Counter B 37 : Rest Counter B 40 : Pulse Input 41 : Switch Set Source 42 : Switch Speed Mode/Torque Mode 50 : External Fault Input 51 : Freeze PID output		25
P2-21	Action for DI as External Fault Input	0 : No Action 2 : Stop and Warning 3 : Jog and Warning 4 : Run to Max Speed P5-03 and Warning 5 : Alarm Fault and Trip to stop 6 : Warning		0
P2-22	DO Function Selection - Terminal DO1	0~91		0
P2-28	Relay Output Function Selection - RL1	Same as P2-22		10
P2-29	Relay on Delay Time - RL1	0.00~600.00	s	0.00
P2-30	Relay off Delay Time - RL1	0.00~600.00	s	0.00
P2-31	Relay Output Function Selection - RL2	Same as P2-22		0
P2-32	Relay on Delay Time - RL2	0.00~600.00	s	0.00
P2-33	Relay off Delay Time - RL2	0.00~600.00	s	0.00

P2-46	Save DI Counter Value at Power down	0 : Save None 1 : Save Counter A 2 : Save Counter B 3 : Save Both Counter A and B		0
P2-50	Min Frequency for Pulse Input 1	0.00~P2-51	kHz	0.00
P2-51	Max Frequency for Pulse Input 1	P2-50~100.00	kHz	50.00
P2-52	Set Value/Feedback Value Versus Min Frequency for Pulse Input 1	-200.00~200.00	%	0.00
P2-53	Set Value/Feedback Value Versus Max Frequency for Pulse Input 1	-200.00~200.00	%	100.00
P2-54	Pulse input 1 Filter Time	1~1000	ms	100
P2-60	Pulse output 1 function selection	0 ~ 30		0
P2-61	Min Frequency for Pulse Output 1	0.00~P2-62	kHz	0.00
P2-62	Max Frequency for Pulse Output 1	P2-61~100.00	kHz	50.00
P2-63	Function Value Versus Min Frequency for Pulse Output 1	0.00~200.00	%	0.00
P2-64	Function Value Versus Max Frequency for Pulse Output 1	0.00~200.00	%	100.00
P2-70	Encoder Resolution	0~4096		1024
P2-71	Encoder Rotation Direction	0: Forward 1: Reverse		0
Parameter Group 3: Analogue Terminal Functions				
P3-00	Signal Type - Terminal AI1	0 : Analogue Voltage 1 : Analogue Current		0
P3-01	Terminal AI1 Filter Time	0.00~10.00	s	0.01
P3-02	Zero Voltage Dead Band - Terminal AI1	0.00~20.00	V/mA	0.00
P3-03	Min Input Voltage - Terminal AI1	0.00~P3-04	V	0.00
P3-04	Max Input Voltage - Terminal AI1	P3-03~10.00	V	10.00
P3-05	Min Input Current - Terminal AI1	0.00~ P3-06	mA	0.00
P3-06	Max Input Current - Terminal AI1	P3-05~20.00	mA	20.00
P3-07	Set Value/Feedback Value Versus Min Input - Terminal AI1	-200.00~200.00	%	0.00
P3-08	Set Value/Feedback Value Versus Max Input - Terminal AI1	-200.00~200.00	%	100.00
P3-09	Signal Type - Terminal AI2	0 : Analogue Voltage 1 : Analogue Current		1
P3-10	Terminal AI2 Filter Time	0.00~10.00	s	0.01
P3-11	Zero Voltage Dead Band - Terminal AI2	0.00~20.00	V/mA	0.00
P3-12	Min Input Voltage - Terminal AI2	0.00~P3-13	V	0.00
P3-13	Max Input Voltage - Terminal AI2	P3-12~10.00	V	10.00
P3-14	Min Input Current - Terminal AI2	P3-15~19.99	mA	0.00
P3-15	Max Input Current - Terminal AI2	P3-14~20.00	mA	20.00
P3-16	Set Value/Feedback Value Versus Min Input - Terminal AI2	-200.00~200.00	%	0.00
P3-17	Set Value/Feedback Value Versus Max Input - Terminal AI2	-200.00~200.00	%	100.00
P3-48	Analogue Live Zero Timeout Time	1~99	s	10
P3-49	Live Zero Timeout Function	0 : No Action 2 : Stop and Warning 3 : Jog and Warning 4 : Run at Max Speed P5-03 and Warning 5 : Alarm Fault and Trip to stop		0
P3-50	Signal Type - Terminal AO1	0 : 0~20mA 1 : 4~20mA 3 : 0~10V		3
P3-51	Output Function Selection- AO1	0~30		0
P3-52	Value Versus Min Output - AO1	0.00~200.00	%	0.00
P3-53	Value Versus Max Output - AO1	0.00~200.00	%	100.00
P3-54	Min Output Voltage/Current - AO1	0.00~P3-55		0.00 /4.00
P3-55	Max Output Voltage/Current - AO1	P3-54~10.00/20.00		10.00 /20.00
P3-68	Min Set Value from Keypad	-200.00~200.00	%	0.00
P3-69	Max Set Value from Keypad	-200.00~200.00	%	100.00
P3-90	Enable Analogue Input as Digital Input	0 : Keep as Analogue Inputs 1 : Enable Analogue Inputs as Digital Inputs		0
P3-91	Function Selection for AI1 as DI	Same as P2-05		0

P3-92	Function Selection for AI2 as DI	Same as P2-05		0
Parameter Group 4: Process PID and Other Controllers				
P4-00	Process PID Feedback Source	0 : No Function 1 : Terminal AI1 2 : Terminal AI2 5 : Pulse Input 1 20 : Bus Communication		0
P4-01	Process PID Set Source	0 : No Function 1 : Terminal AI1 2 : Terminal AI2 5 : Pulse Input 11 10 : Preset Value 0 + UP/DOWN 11 : Multi Preset Value 20 : Bus Communication 30 : Keypad		0
P4-02	Fiducial Value for Process PID Set/Feedback	0.0~3000.0		50.0
P4-04	Process PID Control Logic: Positive/Negative	0 : Positive 1 : Negative		0
P4-05	Process PID Anti Windup	0 : Disable 1 : Enable		1
P4-06	Cut-in Frequency for Process PID Speed Mode	0.0~200.0	Hz	0.0
P4-07	Proportional Gain - Process PID 1	0.0~10.00		0.01
P4-08	Integral Time - Process PID 1	0.01~655.35	s	655.35
P4-09	Differentiating Time - Process PID 1	0.00~10.00	s	0.00
P4-13	Process PID Differential Limit	1.0~50.0		5.0
P4-14	Error Tolerance Limit to Enable Process PID	0.0~200.0	%	0.1
P4-15	Process PID Out/In Mode to Error Tolerance	0~2		0
P4-18	Process PID Output Low Limit	-100.00~100.00	%	0.00
P4-19	Process PID Output High Limit	-100.00~100.00	%	100.00
P4-22	Process PID Integral Output Low Limit	-100.00~100.00	%	0.00
P4-23	Process PID Integral Output High Limit	-100.00~100.00	%	100.00
P4-30	Speed PID Proportional Gain	0.000~1.000		0.010
P4-31	Speed PID Integral Time	2.0~2000.0	ms	8.0
P4-32	Speed PID Differencing Time	0.0~200.0	s	30.0
P4-33	Speed PID Differential Limit	1.000~20.000		5.000
P4-34	Speed PID Speed Signal Filter Time	1.0~100.0		10.0
P4-40	Torque PI Proportional Gain	0~500	%	100
P4-41	Torque PI Integration Time	0.002~2.000	s	0.020
P4-51	PM Current Limit Controller Feedforward Gain	0~400	%	100
P4-52	Proportional Gain - Current Limit Controller	0~500	%	100
P4-53	Integration Time - Current Limit Controller	0.000~2.000	s	0.020
P4-54	Filter Time - Current Limit Control	2.0~100.0	ms	*
P4-61	Isd PI Control Bandwidth	10~200	Hz	30
P4-62	Isd PI Control Damping Coefficient	1~200		100
P4-63	Isd Load Compensation Coefficient	0.1~1.0		0.5
P4-64	Isq PI Control Bandwidth	0.01~1.00	Hz	0.03
P4-65	Isq PI Control Damping Coefficient	1~200		1
Parameter Group 5: Limitation, Protection and Failure Detection				
*P5-02	Motor Low Speed Limit	0.0~590.0	Hz	0.0
*P5-03	Motor High Speed Limit	0.0~590.0	Hz	65.0
P5-04	Torque Limit at Motor Mode	0~1000	%	160
P5-05	Torque Limit at Generator Mode	0~1000	%	160
P5-06	Source Selection for Speed Limit at Torque Mode	0 : No Function 1 : Input From Terminal AI1 2 : Input From Terminal AI1 5 : Pulse Input 1 10: Preset Value 0 + UP/DOWN 11: Preset Value 20 : Bus Communication 30 : Keypad		0
P5-07	Max Current Limit	0~300	%	*
*P5-08	Max Output Frequency Limit	0.0~590.0	Hz	65.0
P5-09	Threshold for Low Current Warning	0.00~P9-16	A	0.0
P5-10	Threshold for High Current Warning	0.00~P9-16	A	*
P5-11	Threshold for Low Speed Warning	0.0~590.0	Hz	0.0
P5-12	Threshold for High Speed Warning	0.1~590.0	Hz	65.0
P5-13	Threshold for Low Set Value Warning	-200.00~200.00	%	0.00
P5-14	Threshold for High Set Value Warning	-200.00~200.00	%	100.00

P5-15	Threshold for Low Feedback Warning	-200.00~200.00	%	0.00
P5-16	Threshold for High Feedback Warning	-200.00~200.00	%	100.00
*P5-17	Enable Motor Phase Loss Protection	0 : Disable 1 : Enable		1
P5-18	Enable Current Limit/Torque Limit Warning	0 : Disable 1 : Enable		1
P5-19	Motor Speed Feedback Loss Function	0 : No Function 3 : Jog and Warning 4 : Run to Max Speed P5-03 and Warning 5 : Alarm Fault and Trip to stop 11 : Switch to Speed Sensor less Mode		5
P5-20	Speed Error for Speed Feedback Loss Detection	1~600	RP M	300
P5-21	Time for Speed Feedback Loss Detection	0.00~60.00	S	0.05
P5-22	Threshold for Communication with CU Timeout	0.10~60.00	S	1.00
P5-23	Communication with CU Timeout Function	0 : No Function 2 : Stop and Warning 3 : Jog and Warning 4 : Run to Max Speed P5-03 and Warning 5 : Alarm Fault and Trip to stop 6 : Warning		5
P5-26	Motor Thermal Protection Function	0 : No Function 1 : ETR Warning 2 : ETR Alarm Fault 3 : ETR Warning for Self-cooled Motor 4 : ETR Alarm Fault for Self-cooled Motor		0
P5-27	Motor Overload Protection Time	1~60	min	2
P5-28	Threshold for Motor Overload Protection	100~160	%	150
P5-29	Function at Mains Phase Loss	0 : No Action 1 : Only Warning 2 : Trip to stop and Alarm Fault (Heavy Load) 3 : Trip to stop and Alarm Fault (Mid Load) 4 : Trip to stop and Alarm Fault (Light Load)		3
P5-30	Alarm/Fault Lock Handling	0 : Not Lock, Alarm/Fault Resettable without Re-Power On 1 : Lock, Alarm/Fault Lock Resettable only after Re-Power On		1
P5-31	Delay Time to Alarm Current Limit Fault	0~60	s	60
P5-32	Delay Time to Alarm Torque Limit Fault	0~60	s	60
P5-33	Action at Warning	0 : Trip to stop and Alarm Fault directly 1 : Warning and Re-catch Motor after Failure Disappear		1
P5-34	Method to Re-catch Motor at Warning	0 : Speed Track(IM/PM) and Angle Track (Fly start) 1 : Direct Re-catch		0
Parameter Group 6: Keypad Operation and Display				
P6-03	Customer Defined Value for 0 Speed	0.0~6553.5		0.0
P6-04	Customer Defined Value for Max Speed	0.0~6553.5		100.0
P6-05	Keypad Display Option	0~8191		0
P6-31	Enabling Local/Remote Mode	0 : Both Enabled 1 : Disable Local Mode 2 : Disable Remote Mode		0
P6-34	Lock Keypad for Parameter Edit	0 : Disabled 1 : Enabled and Lock		0
Parameter Group 7: Auxiliary and Special Functions				
P7-00	Special Operation Function	0 : No Function 9 : Reset Parameters to Factory Defaults		0
P7-01	Function at Re-Power (for Local Mode Only)	0 : Resume with Set Value as Set before Re-power 1 : Not Run, but Keep Set Value as Set before Re-power 2 : Not Run and Clear Set Value		1
*P7-10	Min Switch Frequency	2~16 : 2~16 kHz	kHz	2
*P7-11	Over Modulation Coefficient	90.0~105.5	%	100.0
*P7-12	DC-Link Voltage PWM Compensation Function	0 : Compensate Average DC voltage 2 : Compensate DC Ripple Voltage		0

P7-13	DC-link Voltage PWM Compensation Disable at VF control	0 : Disable 1 : Enable		1
P7-14	Dead Time Compensation Adjustment Coefficient	0~200	%	100
P7-17	Max Speed for Dead Time Compensation	20~590	Hz	*
P7-26	Function at Mains Voltage Sag	0 : No Function 1 : Passive Ramp Down 2 : Passive Ramp Down, Trip 3 : Coast and Fly start 4 : KEB Control 5 : KEB Control, Trip 6 : Trip to stop and Alarm		0
P7-27	Threshold Triggering Mains Voltage Sag Function	100~220/380	V	*
P7-28	KEB Control Gain	0 ~ 500	%	100
P7-36	Method to Reset Alarm Fault	0 : Reset by Command 1~10 : Auto Reset for 1~10 Times 11 : Auto Reset for Unlimited Times		0
P7-37	Alarm Auto Reset Waiting Time	0~600	s	10
*P7-38	VT Function Level	40~90	%	90
*P7-39	Min Magnetron at AEO	40~75	%	66
P7-40	Magnetron Optimization Factor (PM)	-400~400	%	10
P7-46	Threshold Voltage for OVC Function	Grid Voltage Dependent	V	*
P7-47	OVC Function	0 : Disable 1 : Enable with Mode 1 2 : Enable with Mode 2		*
P7-48	OVC Integral Time	0.01~0.10	s	*
P7-49	OVC Proportional Gain	0~200	%	*
P7-50	Bypass Speed Start 1	0.0~590.0	Hz	0.0
P7-51	Bypass Speed End 1	0.0~590.0	Hz	0.0
P7-52	Bypass Speed Start 2	0.0~590.0	Hz	0.0
P7-53	Bypass Speed End 2	0.0~590.0	Hz	0.0
P7-54	Bypass Speed Start 3	0.0~590.0	Hz	0.0
P7-55	Bypass Speed End 3	0.0~590.0	Hz	0.0
Parameter Group 8: Basic and Running Information				
P8-00	PU SW Version			
P8-01	CU SW Version			
P8-30	Total Days with Power On	0~9999		
P8-31	Total Running Hours	0~60000	h	
P8-32	Total Energy Consumed (kWh)	0~65535	kWh	
P8-33	Number of Power Ups	0~65535		
P8-34	Number of Over-Temperatures	0~65535		
P8-35	Number of Over-Voltages	0~65535		
P8-36	Reset Consumed Energy Counter	0 : Not Reset 1 : Reset		0
P8-37	Reset Running Hours Counter	0 : Not Reset 1 : Reset		0
P8-40~P8-49	Alarm Log			
P8-50~P8-59	Warnings Log			
Parameter Group 9: Real Time Running Status Monitoring				
P9-00	Control Word	0~65535		
P9-01	Status Word	0~65535		
P9-02	Set Value	-4999.0~4999.0		
P9-04	Motor Speed	0~24000	rpm	
P9-05	Output Power	0.000~655.35	kW	
P9-06	Output Voltage	0.0~6553.5	V	
P9-07	Output Frequency	0.0~590.0	Hz	
P9-08	Output Current	0.00~655.35	A	
P9-09	Output Torque	-200.0~200.0	%	
P9-10	Motor Thermal Load Status	0~100	%	
P9-11	DC Link Voltage	0~65535	V	
P9-13	Heatsink or IGBT Temperature	-128~127	°C	
P9-14	Inverter Thermal Load Status	0~255	%	
P9-15	Nominal Inverter Current	0.0~6553.5	A	
P9-16	Max Inverter Current	0.0~6553.5	A	
P9-17	Power Board Temperature	-128~127	°C	
P9-18	Rectifier Temperature	-128~127	°C	
P9-19	PID Set Value	-200.0~200.0	%	
P9-20	PID Feedback Value	-200.0~200.0		
P9-21	PID Output	-200.0~200.0	%	
P9-22	Digital Input	0~65535		
P9-23	All Analogue Input Type	0 : 0~10V 1 : 0~20mA		

P9-24	AI1 Input Value	0.00-20.00	V/m A	
P9-25	AI2 Analogue Input Type	0 : 0~10V 1 : 0~20mA		
P9-26	AI2 Input Value	0.00-20.00	V/m A	
P9-34	Set Value by Pulse Input	-200.0~200.0	%	
P9-35	Frequency of Pulse Input	0.00~100.00	KHZ	
P9-37	Speed Feedback from Encoder		Rps	
P9-38	DO Output Status	0~255		
P9-39	Relay Output Status	0~65535		
P9-40	AO1 Output	0.00-20.00	V/m A	
P9-43	Pulse Output Frequency	0.00~100.00	kHz	
P9-45	Counter A Value	0~65535		
P9-46	Counter B Value	0~65535		
P9-47	Set Value from Bus Communication	-32768~32767		
P9-48	Variable Defined by Customer	0~6553.5		

- Note:
- Parameters marked with '*' on the parameter number cannot be changed during motor running.
 - '**' in the Factory default column means the default value vary with the different product types.

2.4 Detailed Description for Parameters

2.4.1 Parameter Group 0: General Control Mode and Commands

Parameter Number	Parameter Name	Value Range	Unit	Factory Default
P0-01	Control Mode	0: Speed Mode Speed Sensor less 1: Speed Mode with Speed Sensor 2: Torque Mode Speed Sensor less 3: Torque Mode with Speed Sensor		0

0: Speed Mode Speed Savorless, Enables speed control (without speed feedback from motor) with automatic slip compensation for almost constant speed at varying loads. Compensations are active but can be disabled.

1: Speed Mode with Speed Sensor, it is suitable for high-accuracy speed control applications. An encoder must be installed at the motor side, and a PG card matching the encoder must be installed at the drive side.

2: Torque Mode Speed Sensor less, torque control in VC 1 mode (P0-02 Motor Control Principle = 1) without speed feedback from motor.

3: Torque Mode with Speed Sensor, torque control in VC 1 mode (P0-02 Motor Control Principle = 1) with speed feedback from motor.

Par. No.	Name	Range	Unit	Default
*P0-02	Motor Control Principle	0: V/F 1: Vector Control 1 2: Vector Control 2		1

Select the motor control principle.

0: V/F, for special motor or parallel connected motors in special motor applications. When V/F is selected the characteristic of VF curve can be set in parameters P1-53/P1-55/P1-57/P1-59/P1-61 for voltages and P1-54/P1-56/P1-58/P1-60/P1-621 for frequencies

1: Vector Control 1, Vector Control by decoupling the magnet current and torque current, suitable for most general applications. Correct motor parameters are important to achieve the best performance. Only VC 1 supports PM motor;

2: Vector Control 2, Suitable for applications demanding higher start torque or higher load impact performance. More sensitive to motor parameters and parameters P4-5* and P4-6* need to be tuned carefully.

Par. No.	Name	Range	Unit	Default
*P0-04	Torque Characteristics	0 : CT 1 : VT 9 : AEO		0

Select the torque characteristic of the load.

0: Constant torque, Load keeps high torque to the motor also at low speed, applies to most industry applications.

1: Variable torque, Load torque to the motor varies with the speed change, normally lower torque at lower speed, usually applies to fan or pump applications.

9: Auto Energy optimization (AEO), Automatically optimizes energy consumption by optimizing the magnet current. Usually suitable for fan or pump applications.

Par. No.	Name	Range	Unit	Default
*P0-05	Motor Speed Direction	0 : Clockwise 1 : Anticlockwise 2 : Bidirectional		2

Select the motor speed direction(s). It can be used to prevent unwanted motor direction.

0: Clockwise, the motor shaft rotates in clockwise direction, this setting prevents the motor from running in counter clockwise direction;

1: Anticlockwise, motor shaft rotates in anticlockwise direction, this setting prevents the motor from running in clockwise direction;

2: Both directions, with this setting, the motor can run in both directions;

Par. No.	Name	Range	Unit	Default
*P0-06	Dual Rating Selection	0: Heavy Load 1: Light Load		0

0: Heavy Load, for most industry applications in which the motor needs to run at low speed with full torque

1: Light Load, for applications like fans, pumps or compressors in which the motor does not need full torque at low speed or does not run at low speed continuously. With this setting, the product can support one size up in the motor power or in the output current with less over load capacity.

Par. No.	Name	Range	Unit	Default
P0-10	Speed Set Source Selection	0~5		0

Select set value source.

0: main set source, only the main set source is used;

1: Multi preset value with priority

For example, set P0-11 = 1 (All as main set source), P0-12 = 13 (Mulita preset value as additional set source), P2-07 = 22, P2-08 = 23, P2-09 = 24, P2-10 =25 If DI1 is valid and DI2, DI3 and DI4 are invalid, the set value is P0-31. If DI1~DI4 are all invalid, the set value is corresponding to the value of All. Note that P0-30 cannot have the priority.

2: Calculation of main set source and additional set source.

3: Switchover between main set source and additional set source.

The set source can be switched by the digital input terminal function (one of the parameters from P2-05 to P2-10 set to 41). When the corresponding terminal is invalid, the main set source is selected; when the terminal is valid, the additional set source is selected.

4: Switchover between main set source and the calculation of main set source and additional set source

5: Switchover between additional set source and the calculation of main set source and additional set source

Selecting 4 or 5 works similar as selecting 3.

Par. No.	Name	Range	Unit	Default
P0-11	Main Set Source	0~30		1
P0-12	Additional Set Source	Same as P0-11		20

Select the source for main set and additional set.

0: No function;

1: Terminal AI1, use analogue input AI1 as set source, refer to P3-00~P3-17;

2: Terminal AI2, use analogue input AI1 as set source, refer to P3-00~P3-17;

5: Pulse input, use pulse input as set source, refer to P2-50~P2-53;

10: Multi preset value 0 + Up/Down, use preset set value 0 plus Up/Down adjustment as set source, refer to P0-30~P0-45, P0-46 and P2-05;

11: Multi preset values, refer to ever to P0-30~P0-45 and P2-05;

20: Communication, use value from bus compunction;

21: Process PID, use the output of Process PID control as set source;

30: Keypad, use the command for keypad as set resource, refer to P3-68~P3-69;

Par. No.	Name	Range	Unit	Default
P0-13	Torque Set Source for Torque Mode	Same as P0-11		1

Select the set source for torque control, the base value for set source is based on P1-08 rated motor torque.

Par. No.	Name	Range	Unit	Default
P0-14	Set Value Calculation from Main and Additional Source	0 : Main Set Source + Additional Set Source 1 : Main Set Source - Additional Set Source 2 : Maximal Value of Main and Additional Set Source 3 : Minimal Value of Main and Additional Set Source		0

This parameter is used to set calculation of main and additional set source, the calculated results can be used for parameter P0-10 options [2], [4] and [5].

Based on Parameter P0-10, P0-11, P0-12, P0-14, the set value for speed mode can be calculated as below:

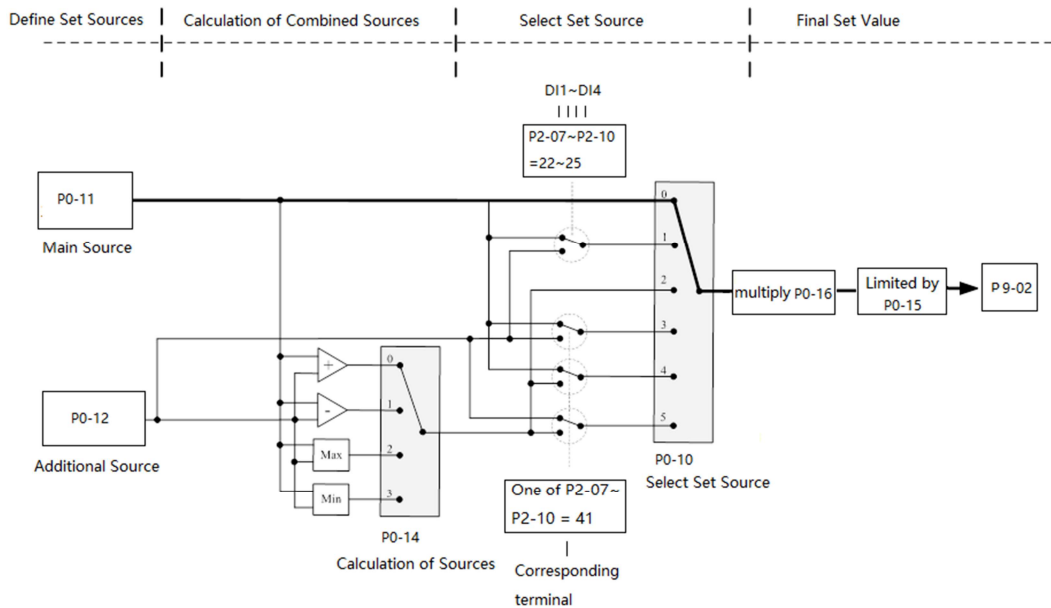

Par. No.	Name	Range	Unit	Default
P0-15	Speed Set Range	0 : 0~P0-16 1 : -P0-16~P0-16		0
P0-16	Base Value for Speed Set	0.0~590.0		50.0

These two parameters are used to control the range of the set value and used as percentage calculation base.

Par. No.	Name	Range	Unit	Default
P0-17	Control Site	0 : Terminal or Bus Communication 1 : Terminal 2 : Bus Communication		0

The start, stop, reverse, jog commands can be given both through digital input terminals and communication, this parameter is used to select the drive control command site.

0: Terminal or Bus Communication, controlled by both digital input terminals and bus communication;

1: Terminal, controlled only by digital input terminals;

2: Communication only, controlled by bus communication only;

Par. No.	Name	Range	Unit	Default
P0-18	Selection of Communication Control Source	0 : Null 1 : Local RS485 2 : Bus from Option Card		1

Par. No.	Name	Range	Unit	Default
P0-30~P0-45	Multi Preset Values	-100.00~100.00	%	0.00

Different values preset in P0-30~P0-45 can be activated by different status of DI1 ~DI4 terminals (P2-07~P2-10 are set to [22] ~ [25])

For the relationship between active preset value and the status of DI terminals.

Preset Value Command Bit 4	Preset Value Command Bit 3	Preset Value Command Bit 2	Preset Value Command Bit 1	Parameter selected
OFF	OFF	OFF	OFF	P0-30
OFF	OFF	OFF	ON	P0-31
OFF	OFF	ON	OFF	P0-32
OFF	OFF	ON	ON	P0-33
OFF	ON	OFF	OFF	P0-34
OFF	ON	OFF	ON	P0-35
OFF	ON	ON	OFF	P0-36
OFF	ON	ON	ON	P0-37
Preset Value Command Bit 4	Preset Value Command Bit 3	Preset Value Command Bit 2	Preset Value Command Bit 1	Parameter selected
ON	OFF	OFF	OFF	P0-38
ON	OFF	OFF	ON	P0-39
ON	OFF	ON	OFF	P0-40
ON	OFF	ON	ON	P0-41
ON	ON	OFF	OFF	P0-42
ON	ON	OFF	ON	P0-43
ON	ON	ON	OFF	P0-44
ON	ON	ON	ON	P0-45

In speed control mode, 100% preset value is corresponding to P0-16. In torque control mode, 100% is corresponding to P1-08 rated motor torque.

Par. No.	Name	Range	Unit	Default
P0-46	UP/DOWN Step Value	0.01~50.00		0.10

To set the set value change step each time when a DI terminal valid. The corresponding terminal must be set with UP/DOWN function for UP/Down function (one of parameters from P2-05 to P2-10 set to [30] [31]). The UP/DOWN function is used when parameter P0-11 or P0-12 is set to [10].

Par. No.	Name	Range	Unit	Default
P0-47	Save Up/Down Set Value	0 : Not Save 1 : Save when Stop 2 : Save when Power Down		0

This parameter is used for setting whether to save the set value changed by Up/Down function if the drive stops or after it is powered down.

Par. No.	Name	Range	Unit	Default
P0-48	Jog Speed	0.0~400.0	Hz	0.0

The jog speed is a fixed output speed at which the drive is running when the jog function is activated by DI terminal.

Jog speed has the highest priority when a variety of commands are activated.

Par. No.	Name	Range	Unit	Default
P0-49	Ramp Time Resolution	0 : 0.1s 1 : 0.01s		1

There are two kinds of ramp time resolution for different applications.
 After modifying this parameter, the ramp time defined in P0-51~P0-66 will be reset back to factory defaults.

Par. No.	Name	Range	Unit	Default
P0-50	Ramp 1 Type	0 : Linear 1 : S ramp		0
P0-51	Ramp 1 Ramp Up Time	0.05~655.35	s	*
P0-52	Ramp 1 Ramp Down Time	0.05~655.35	s	*
P0-53	Ramp 2 Type	0 : Linear 1 : S ramp		0
P0-54	Ramp 2 Ramp Up Time	0.05~655.35	s	*
P0-55	Ramp 2 Ramp Down Time	0.05~655.35	s	*
P0-56	Ramp 3 Type	0 : Linear 1 : S ramp		0
P0-57	Ramp 3 Ramp Up Time	0.05~655.35	s	*
P0-58	Ramp 3 Ramp Down Time	0.05~655.35	s	*
P0-59	Ramp 4 Type	0 : Linear 1 : S ramp		0
P0-60	Ramp 4 Ramp Up Time	0.05~655.35	s	*
P0-61	Ramp 4 Ramp Down Time	0.05~655.35	s	*
P0-62	Jog Ramp Time	0.05~655.35	s	*
P0-63	S Ramp Up Initiate Period	0.05~655.35	s	*
P0-64	S Ramp Up Termination Period	0.05~655.35	s	*
P0-65	S Ramp Down Initiate Period	0.05~655.35	s	*
P0-66	S Ramp Down Termination Period	0.05~655.35	s	*

Ramp Up Time: The total ramp time from 0Hz to rated motor frequency (P1-05)
 Ramp Down Time: The total ramp time from rated motor frequency (P1-05) to 0Hz.

Ramp Type:

- 0: Linear, motor ramps up/down with constant acceleration/deceleration speed;
- 2: S ramp, motor ramps up/down with changing acceleration/deceleration speed to get a smooth speed change. Normally the changing speed of acceleration/deceleration speed is constant.

The ramp times and ramp types are shown below:

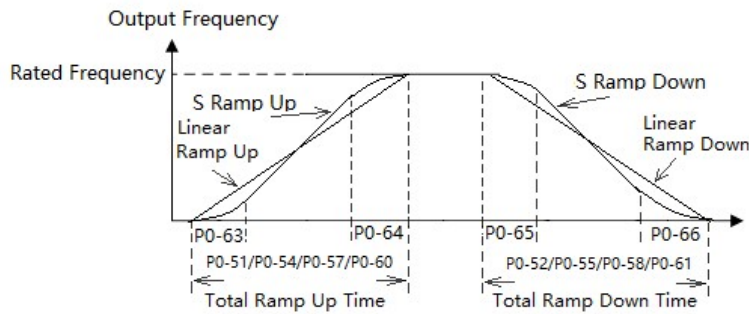

F or S ramp, P0-63 plus P0-64 should not be more than the total ramp up time defined by P0-51/P0-54/P0-57/P0-60, P0-65 plus P0-66 should not be more than the total ramp down time defined by P0-52/P0-55/P0-58/P0-61.

Par. No.	Name	Range	Unit	Default
P0-80	Local Address	1~127		1

Select the address for the bus communication.

Par. No.	Name	Range	Unit	Default
P0-81	Baud Rate	0 : 2400 1 : 4800 2 : 9600 3 : 19200 4 : 38400 5~9 : Reserved		2

Select baud rate for bus communication.

Par. No.	Name	Range	Unit	Default
----------	------	-------	------	---------

P0-82	Communication Data Format (Parity/Stop Bits)	0 : Even parity (1 stop bit) 1 : Odd parity (1 stop bit) 2 : No parity (1 stop bit) 3 : No parity (2 stop bit)		0
-------	--	---	--	---

Par. No.	Name	Range	Unit	Default
P0-83	Min. Communication Response Delay	0.000~0.500	s	0.002

Specify the minimum delay time between receiving a request and transmitting a response. This is used for overcoming modem turnaround delays.

Par. No.	Name	Range	Unit	Default
P0-84	Max. Communication Response Delay	0.010~10.000	s	5.000

Specify the maximum permissible delay time between transmitting a request and receiving a response. If the delay time exceeds this value, the drive will not respond to received data.

Par. No.	Name	Range	Unit	Default
P0-85	Message Response	0 : Normal Responses 1 : Only Response Exceptional Message 2 : Not Response		0

This parameter is used to control Modbus message response.

Attention: the drive will response to the READ command and not response to the RADIO message no matter what P0-85 set.

Par. No.	Name	Range	Unit	Default
P0-86	Parameter (Set by Communication) Saving at Power Down	0 : Not Save Parameter at Power Down 1 : Save Parameter at Power Down		0

This parameter is used to control whether the parameters which is changed by communication WRITE command should be saved at power down.

Par. No.	Name	Range	Unit	Default
P0-87	Communication terminal resistance selection	0 : Open 1 : Close		0

This parameter is to enable the built-in termination resistor for RS485 bus.

Par. No.	Name	Range	Unit	Default
P0-88	Communication Timeout Time	0.01~650.00	s	1.00

If the time between two successful reception of telegrams exceeds this parameter, it indicates that the communication has stopped or failed, then the function set in P0-89 (Communication Timeout Function) will be activated. If this parameter is set to 0, then the timeout function defined in P0-89 is disabled.

Note: The time-out counter is triggered ONLY by a valid communication, so if the product never received any successful telegrams from power on, it will never trigger timeout function.

Par. No.	Name	Range	Unit	Default
P0-89	Communication Timeout Response Function	0 : No Function 2 : Stop Motor 3 : Jogging 4 : Run with Max Frequency P5-03 5 : Trip to stop and Alarm Fault 6 : Warning		0

The communication time-out function is activated if the product fails to receive successful telegram within the time period specified in P0-88 Communication Timeout Time.

0: No function, no response, control with the latest received control word.

2: Stop, overruled to stop;

3: Jogging, overruled to jog speed running;

4: Max. speed, overruled to max. speed running;

5: Trip to stop and alarm fault, trip to stop and alarm fault "A.62".

6: Warning, warning with "u.62" and control with the latest received control word

Par. No.	Name	Range	Unit	Default
P0-90	Reset Communication Timeout	0 : No Action 1 : Reset the Timeout		0

The Communication Timeout flag can only be reset by this parameter. If the flag is not reset, even communication recovers and the alarm is cleared, the drive will continue to report communication timeout.

2.4.2 Group 1 Basics for Inverter and Motor Control

Par. No.	Name	Range	Unit	Default
P1-00	Switching Frequency	2~16 : 2~16 kHz		*

Switching frequency has a significant influence to the drive and the motor. Select appropriate switch frequency can help to adjust acoustic noise from the motor, output harmonics, temperature of motor, the drive efficiency, as well as the EMC noise.

Par. No.	Name	Range	Unit	Default
*P1-01	Grid Type	2~122		*

Selects the grid type. Output frequency and voltage will be changed according to the grid type.

2: 200-240V/50Hz

12: 380-440V/50Hz
 22: 440-480V/50Hz
 102: 220-240V/60Hz
 112: 380-440V/60Hz
 122: 440-480V/60Hz

Par. No.	Name	Range	Unit	Default
*P1-02	Motor Type	0 : Induction Motor 1 : SPM 2 : IPM without Saturation 3 : IPM with Saturation		0

Different parameters are active when the option is selected. See the following table, “√” means active.

	[0] Induction Motor	[1] ~ [3] PM Motor
P0-04 Torque Characteristics	√	
P1-18 Ld, PM D-axis Inductance		√
P1-19 Lq, PM Q-axis Inductance		√
P1-20 Ld-s, PM D-axis Inductance Saturated		√
P1-21 Lq-s, PM Q-axis Inductance Saturated		√
P1-22 Saturation Current at D-axis for Ld-s		√
P1-23 Saturation Current at Q-axis for Lq-s		√
P1-24 Number of Motor Poles		√
P1-25 BEMF at Rated Speed for PM		√
P1-27 System Inertia		√
P1-32 Load Compensation Gain for Low Speed	√	
P1-33 Load Compensation Gain for High Speed	√	
P1-34 Motor Magnet Current for Low P1-32 Speed	√	
P1-35 Cut In Speed for Normal Magnet Current	√	
P1-36 Min Motor Current at Low Speed		√
P1-37 Slip Compensation Gain	√	
P1-38 Slip Compensation Time Constant	√	
P1-39 Resonance Damping Gain	√	
P1-40 Time Constant for Resonance Damping Filter	√	
P1-41 Damping Coefficient for PM		√
P1-42 Damping Time Constant for Low Speed range (PM)		√
P1-43 Damping Time Constant for High Speed range (PM)		√
P1-44 Time Constant for Current Filter (PM)		√
P1-53~P1-62 V/F curve points	√	
P1-63 PM Start Method		√
P1-64 IM Start Method	√	
P1-86 Parking Current (PM Start)		√
P1-87 Parking Time (PM Start)		√

Note : Only the key parameters are listed above. Please check the description for each parameter.

Par. No.	Name	Range	Unit	Default
*P1-03	Rated Motor Power	0.12~450	kW	*
*P1-04	Rated Motor Voltage	50~1000	V	*
*P1-05	Rated Motor Frequency	20~400	Hz	*
*P1-06	Rated Motor Current	0.1~1200	A	*
*P1-07	Rated Motor Speed	100~24000	rpm	*
*P1-08	Rated Motor Torque	0.1~6553.5	N·m	*

Set the parameters according to the motor nameplate no matter which control mode is adopted. Changing the value of P1-03 and P1-04 will automatically reset the parameters P1-14 ~ P1-23 to factory defaults

Par. No.	Name	Range	Unit	Default
*P1-13	Auto Tuning for Motor Parameters	0 : No Function 1 : Simple Static Motor Auto Tuning 2 : Complete Static Motor Auto Tuning 3 : Complete Static Motor Auto Tuning + Spinning BEMF (PM) 4 : Complete Static Motor Auto Tuning + Spinning Inertia (PM) 5 : Complete Static Motor Auto Tuning + Spinning BEMF (PM) + Spinning Inertia (PM)		0

Use Automatic Motor Adaption (AMA) to obtain accurate motor parameters to further optimize control performance.

Please be noticed that, BEMF and Inertia tuning need to rotate the motor (no need to disconnect the load) and tuning for other parameters can run without rotating the motor. BEMF and Inertia tuning only work for PM motor. Simple static tuning only works for the stator resistor.

The parameters obtained in different auto tuning states are listed as below:

Auto Tuning State	IM motor	PM motor
Stator Resistance Tuning	P1-14 Stator Resistance (Rs)	P1-14 Stator Resistance (Rs)

Inductance Tuning	P1-16 Stator Leakage Reactance (X1) P1-17 Main Reactance (Xh)	P1-18 Ld, PM D-axis Inductance P1-19 Lq, PM Q-axis Inductance P1-20 Ld-s, PM D-axis Inductance Saturated P1-21 Lq-s, PM Q-axis Inductance Saturated P1-22 Saturation Current at D-axis for Ld-s P1-23 Saturation Current at Q-axis for Lq-s
BEMF Tuning	NA	P1-25 BEMF at Rated Speed for PM
Sytem Inertia Tuning	NA	P1-27 System Inertia

Before running the motor parameter auto tuning function, below motor parameters should be set correctly based on the motor nameplate: P1-03 Rated Motor Power, P1-04 Rated Motor Voltage, P1-05 Rated Motor Frequency, P1-06 Rated Motor Current, P1-07 Rated Motor Speed.

You can stop the Auto Tuning process by press the “STOP” key.

For the system inertia tuning, the inverter will ramp up and ramp down the motor and the ramp down process is impacted by parameter P7-47 over voltage control. If over voltage control is enabled, the DC voltage will be controlled at a fixed value (680Vdc for 400v products)

Par. No.	Name	Range	Unit	Default
*P1-14	Stator Resistance (Rs)	0.001~65.535	Ω	*
*P1-15	Rotor Resistance (Rr)	0.001~65.535	Ω	*
*P1-16	Stator Leakage Reactance (X1)	0.001~65.535	Ω	*
*P1-17	Main Reactance (Xh)	0.01~655.35	Ω	*
*P1-18	Ld, PM D-axis Inductance	0.01~655.35	mH	*
*P1-19	Lq, PM Q-axis Inductance	0.01~655.35	mH	*
*P1-20	Ld-s, PM D-axis Inductance Saturated	0.01~655.35	mH	*
*P1-21	Lq-s, PM Q-axis Inductance Saturated	0.01~655.35	mH	*
*P1-22	Saturation Current at D-axis for Ld-s	20~200	%	100
*P1-23	Saturation Current at Q-axis for Lq-s	20~200	%	100

Normally you cannot get these values from the motor nameplate, you need to run the motor parameter auto tuning function or ask them from the motor supplier. If you failed to do both, then the factory defaults will be used for control which cannot be used to achieve the proper performance.

Par. No.	Name	Range	Unit	Default
*P1-24	Number of Motor Poles	2~100	P	4

Par. No.	Name	Range	Unit	Default
*P1-25	BEMF at Rated Speed for PM	0~9000	V	*

Back EMF is the voltage generated by a PM motor when supply is connected and the shaft is turned by mechanic force or inertia speed. Back EMF is normally specified as the voltage measure between two phases at certain motor speed when no supply is connected.

Par. No.	Name	Range	Unit	Default
*P1-26	Motor Cable Length	0~150	m	10

Enter the motor cable length connected between the motor and the drive. Set correct cable length can suppress noises resulted from the motor.

Par. No.	Name	Range	Unit	Default
*P1-27	System Inertia	0.00~655.35	kg·m ²	*

This parameter normally needs to be obtained by auto tuning function.

Par. No.	Name	Range	Unit	Default
P1-32	Load Compensation Gain for Low Speed	0~199	%	100
P1-33	Load Compensation Gain for High Speed	0~199	%	100

Enter the % value to compensate voltage in relation to load when the motor is running at low speed (P1-32)/high speed (P1-33) and obtain the optimum load characteristic.

The low and high-speed change-over point is automatically calculated based on motor size. Usually it is 5Hz.

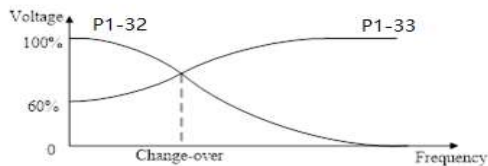

Par. No.	Name	Range	Unit	Default
P1-34	Motor Magnet Current at 0 Speed	0~300	%	100
P1-35	Cut in Speed for Normal Magnet Current	0.0~10.0	Hz	0.0

Use P1-34 Motor Magnet Current at 0 Speed along with P1-35 Cut in speed for Normal Magnet Current to obtain different thermal load and shaft performance on the motor when running at low speed (under P1-35). If the setting is too low, the torque on the motor shaft may be reduced.

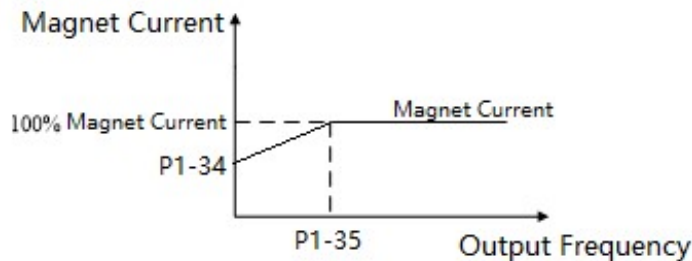

Par. No.	Name	Range	Unit	Default
P1-36	Min Motor Current at Low Speed	0~120	%	80

Define the minimum motor current at low speed to ensure the ability to start motor with load. This parameter works only for PM motor

Par. No.	Name	Range	Unit	Default
P1-37	Slip Compensation Gain	-400~399	%	*

When the motor is running at a motoring state, motor speed drops with the increase of load. When the motor is running at a generating state, motor speed will increase with the increase of load. Appropriate slip compensation can maintain constant motor speed when the motor load is changing. If this parameter is set to 100%, it indicates that the compensation when the motor bears rated load is the rated motor slip.

Diagram of slip compensation is shown below:

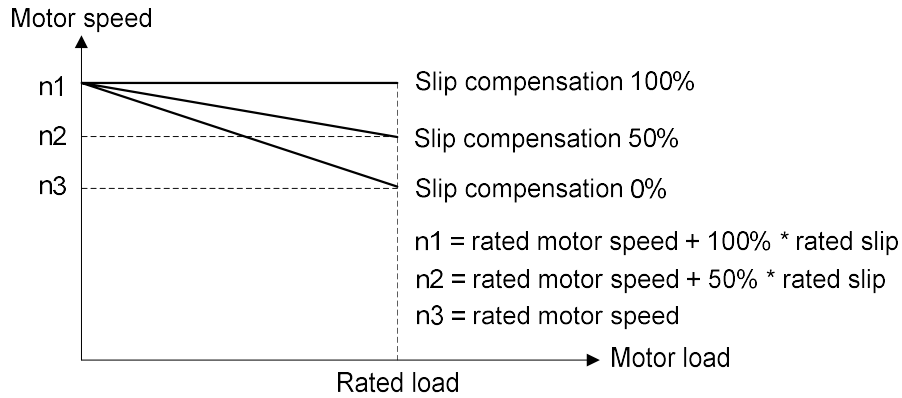

Slip compensation at motoring state

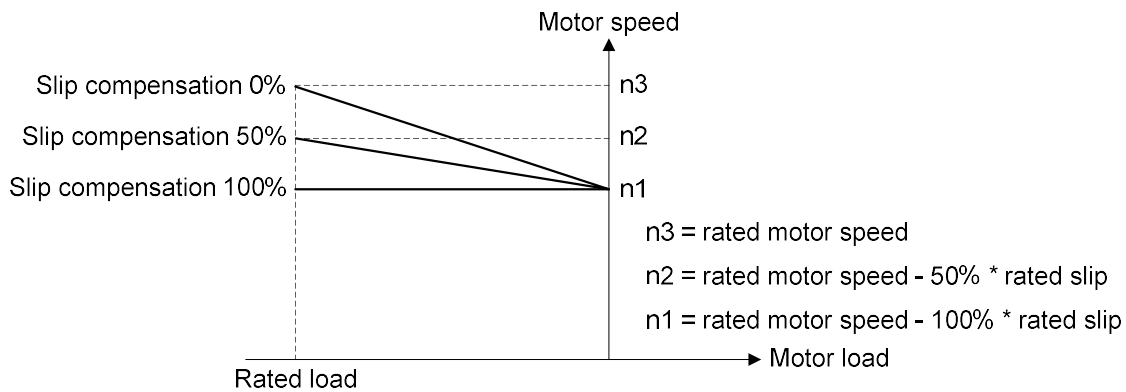

Slip compensation at generating state

When having more than one motor on the same shaft there is a need for some kinds of load sharing between the motors. This can be achieved by running motors in speed open loop and one with 0 or negative slip compensation, so called droop control.

Par. No.	Name	Range	Unit	Default
P1-38	Slip Compensation Time Constant	0.05~5.00	s	*

This parameter is to control the response speed of slip compensation, a higher value a slower reaction. If low frequency resonance problems occur, set it to a high value.

Par. No.	Name	Range	Unit	Default
P1-39	Resonance Damping Gain	0~3000	%	*
P1-40	Time Constant for Resonance Damping Filter	0.005~0.050	s	0.005

Motor (especially $\geq 30\text{kW}$ motor) speed and current resonance is likely to occur due to load vibration, and may lead to system failure even trigger the over current protection. This is particularly obvious during no-load or light-load applications. Do not change these parameters if the motor has no resonance. Increase the P1-39 value properly only when the motor has obvious resonance. The larger the value is, the better the resonance dampening result will be. But a higher value in P1-39 will reduce the speed response performance. P1-40 should be set properly to ensure the damping function, a smaller value makes the response of damping function faster, but two small value can result in instability of the control.

Par. No.	Name	Range	Unit	Default
P1-41	Damping Coefficient for PM	0~250	%	120

The value of P1-41 controls the dynamic performance of the PM motor. Higher value gives higher dynamic performance. Lower value gives lower dynamic performance but it's better to control the mechanical resonance. If the damping gain is too high or low, the control becomes unstable.

Par. No.	Name	Range	Unit	Default
----------	------	-------	------	---------

P1-42	Damping Time Constant for Low Speed range (PM)	0.01~20.00	s	0.8
-------	--	------------	---	-----

This time constant is used below 10% rated speed. Obtain quick control through a short damping time constant. However, if this value is too short, the control could become unstable.

Par. No.	Name	Range	Unit	Default
P1-43	Damping Time Constant for High Speed range (PM)	0.01~20.00	s	0.8

This time constant is used above 10% rated speed. Obtain quick control through a short damping time constant. However, if this value is too short, the control could become unstable.

Par. No.	Name	Range	Unit	Default
P1-44	Time Constant for Current Filter (PM)	0.001~1.000	s	0.5

To reduce the influence of high frequency ripple and system resonance in the calculation of control voltage, a current filter is necessary, without this filter, the ripples in the currents can distort the calculated voltage and affect the stability of the system

Par. No.	Name	Range	Unit	Default
P1-45	Min Torque at Torque Mode Start	-100~100	%	5
P1-46	Min Torque Cut Out Speed at Torque Mode Start	0.1~50.0	Hz	3.0

In torque control mode, the device may not start if the torque reference is too small due to the presence of static friction, so a minimum torque set at low speed is necessary to start the load. The below figure shows how the torque is set with these two parameters.

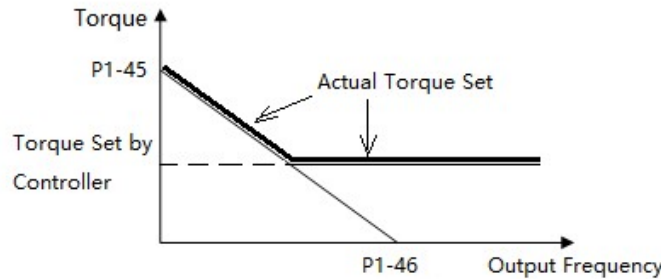

Par. No.	Name	Range	Unit	Default
P1-53/P1-55/P1-57/P1-59/P1-61	Voltage for V/F curve	0.0~999.9	V	*
P1-54/P1-56/P1-58/P1-60/P1-62	Frequency for V/F curve	0.0~590.0	Hz	*

P1-53~P1-62 are used to define the VF curve to achieve the best load performance for a special motor. The curve is defined as below:

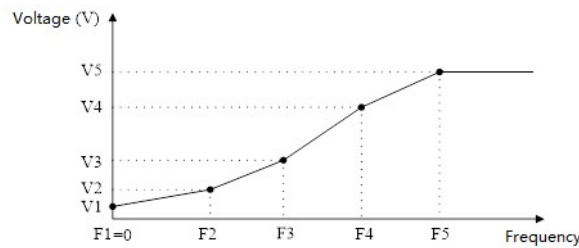

P1-53/P1-55/P1-57/P1-59/P1-61 corresponds to V1~V5 and P1-54/P1-56/P1-58/P1-60/P1-62 corresponds to F1~F5. Below rules must be followed for the set: $F1=0$ and $F1 \leq F2 \leq F3 \leq F4 \leq F5$. If necessary, you can merge two or more points into one to simplify the VF curve, an example as below:

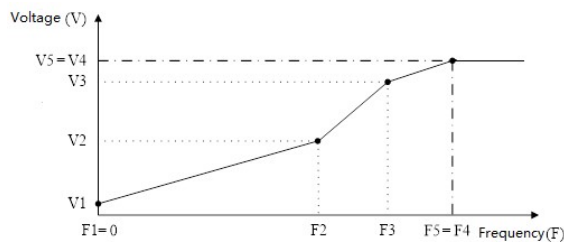

The default V/F curves are set as below.

220V Products	Voltage	P1-53 0.0	P1-55 7.0	P1-57 220.0	P1-59 220.0	P1-61 220.0
	Frequency	P1-54 0.0	P1-56 0.5	P1-58 50.0	P1-60 50.0	P1-62 50.0
380V Products	Voltage	P1-53	P1-55	P1-57	P1-59	P1-61

	0.0	12.0	380.0	380.0	380.0
Frequency	P1-54	P1-56	P1-58	P1-60	P1-62
	0.0	0.5	50.0	50.0	50.0

Note: The VF curve only work in VF control mode (P0.02=0). Two high voltage at low frequency could trigger the over current protection and damage the motor due to high current and temperature.

Par. No.	Name	Range	Unit	Default
P1-63	PM Start Method	0 : Initial Position Detection (IPD) 1 : Parking		1

Since the drive does not know the actual rotor position at start-up, a parking or an initial position detection (IPD) process is required. The initial position detection starts quickly and its time can generally be ignored.

For parking start, the parking time is determined by P1-87.

Note: For PM motor, at start the product will try to track the speed and angle of the motor. If it succeeds, it will start directly according to the motor speed and angle.

Par. No.	Name	Range	Unit	Default
*P1-64	IM Start Method	0 : Direct Start 1 : Fly start		0

If the IM motor is rotating, it cannot be controlled from 0Hz directly. Doing so will result in very high current damaging the product or fail to start. Enabling the fly start function (P1-64=1), the product will track the motor speed first and start with the speed tracked. If no rotating motor is found, the product will assume the motor is standstill and start the motor from 0 Hz.

When flying start is enabled, P1-70 Delay Time at Start and P1-71 Delay Function at Start is disabled.

Par. No.	Name	Range	Unit	Default
P1-67	Min Valid Speed Set	0.00~50.00	Hz	0.00

Only when the absolute value of the set speed is not less than P1-67, the product can be started. If a speed set of absolute value less than P1-67 is given, the product will treat it as a stop command and 0Hz speed set.

Note: The product will ramp through the Min Valid Speed Set range still if a valid speed set is given, e.g., if 20Hz is set and P1-67 = 5.0, the product will ramp from 0Hz, through 1Hz, 2Hz ... 5Hz to 20Hz.

Par. No.	Name	Range	Unit	Default
P1-68	Bypass Range for IM Low Speed	0.0~20.0	Hz	0.0

If the set speed's absolute value is less than P1-68, the drive will run at the frequency defined P1-68. If the set speed's absolute value is higher than P1-68, the product will start from P1-68 directly and then ramp to the set speed. Please be noted that P1-68 only control the absolute value of the speed command, it will not change the motor direction. For example:

Set P1-68 = 3. If the set speed is 2, the product will run forward at 3Hz; If the set speed is -2, the product will run reverse at 3Hz. If the set speed is 20, the product will run at 3Hz immediately, then accelerates from 3Hz to 20Hz using ramp time. If the set speed change from 20Hz to -20Hz, the product will ramp down to 3Hz first, then jump to -3Hz immediately and ramp to -20Hz. If the frequency reference is 0, the drive will ramp down to 3Hz first and stop directly from 3Hz.

Note:

1. It is not recommended for using P1-67 and P1-68 together.
2. If both P1-68 and P1-84 are enabled (higher than 0), DC brake will only be active when P1-84 > P1-68.

Par. No.	Name	Range	Unit	Default
P1-70	Delay Time at Start	0.0~10.0	s	0.0
P1-71	Delay Function at Start	0 : Free Coast 1 : DC Hold		0

P1-70 enables a delay time from receiving the start command given to starting the motor. The drive begins with the start function selected in P1-71 during the P1-70 delay time first then start the motor. Setting the delay time to 0.0 disables P1-71 delay function. P1-71 delay function is described as below:

- 0: Coast, Motor coasts during the start delay time (drive off);
1: DC Hold, energizes motor with a DC holding current (P1-72 DC Hold Current) during the start delay time;

Note: 1. The P1-70 Delay Time will not be included in the ramp up time.

2. When fly start is enabled (P1-64=1), the P1-71 Delay function will be disabled.

Par. No.	Name	Range	Unit	Default
P1-72	DC Hold Current	0~150	%	50

Enter a value for holding current as a percentage of the rated motor current set in P1-06 Rated Motor Current. Customer can use this parameter to either hold the motor (holding torque) or pre-heat the motor. This parameter is active if DC Hold has been selected in either P1-71 or P1-80. The difference is that, for P1-71 delay function as start, the DC hold current will only continue during P1-70 delay time, but for P1-80 Hold Function at Stop, the DC hold current will continue at stop until a start command is given.

Par. No.	Name	Range	Unit	Default
P1-79	Stop Method at Torque Control Mode	0 : Stop with Torque Mode 1 : Stop with Speed Mode		0

This parameter is used to set the stop mode in torque control mode:

- 0: Torque mode. When stop command is activated, the set torque is reduced to zero according to the ramp down time.
1: Speed mode. When stop command is activated, the set speed is reduced to zero according to the ramp down time.

Par. No.	Name	Range	Unit	Default
P1-80	Function at Stop	0 : Free Coast 1 : DC hold		0

P1-81	Cut in Speed for Function at Stop	0.0~400.0	Hz	0.0
-------	-----------------------------------	-----------	----	-----

P1-80 Selects the function when stop command is given and the speed is ramped down to P1-81 Cut in Speed for Function at Stop.

- 0: Free Coast, disable the output of the product and the motor coasts;
- 1: DC hold, the motor is energized with a DC current as P1-72 DC Hold Current;

Diagram of Function at Stop is shown below:

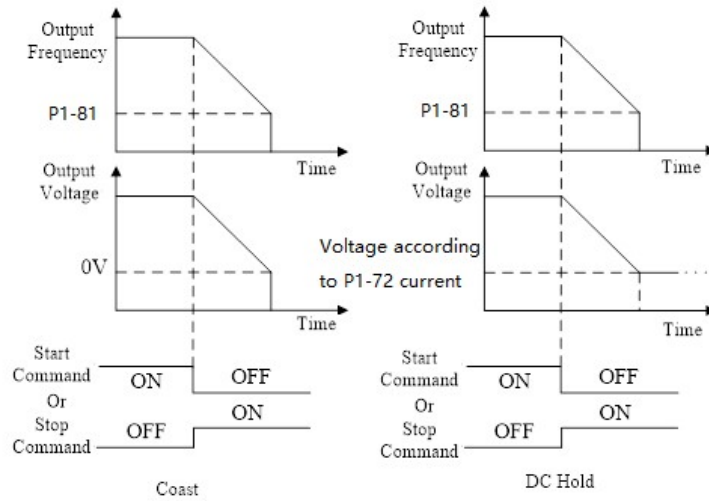

Note: If P1-81 > P1-84, the P1-80 function at stop will work and the DC brake function will not; if P1-81 < P1-84, the DC brake function will work. And the P1-80 function at stop will not.

Par. No.	Name	Range	Unit	Default
P1-82	DC Brake Current (IM)	0~150	%	50
P1-83	DC Brake Time (IM)	0.0~60.0	s	2
P1-84	DC Brake Cut in Speed (IM)	0.0~400.0	Hz	0.0
P1-85	Demagnetizing Rate at DC Cut in	0~100	%	100

DC brake is to apply a DC current on the motor to brake and hold the motor when motor speed ramps down to a low speed at stop command. P1-82 defines the DC brake current as a percentage of P1-06 Rated Motor Current. P1-83 defines how long time the DC current should be applied. P1-84 defines at which speed to start the DC brake current. Between normal ramp down and the DC brake current applied, a Demagnetizing period is necessary to avoid possible current spikes. P1-85 defines how fast the demagnetizing period will finished. Higher P1-85 value needs longer time for demagnetizing, means more time delay before the DC brake current is applied.

Diagram of DC Brake process is shown below:

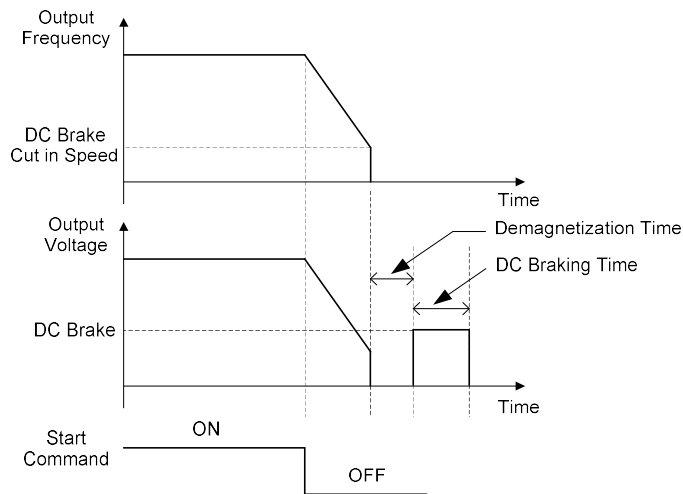

Note: P1-85 also works for P1-80.

Par. No.	Name	Range	Unit	Default
P1-86	Parking Current (PM Start)	0~150	%	80
P1-87	Parking Time (PM Start)	0.1~60.0	s	3.0

This group of parameters are enabled when P1-63 PM Start Mode is equal to [1] Parking. P1-87 is used to determine the parking time. P1-86 is used to determine the current during the parking process. 100% corresponds to P1-06 rated motor current.

Par. No.	Name	Range	Unit	Default
----------	------	-------	------	---------

P1-91	Brake Function	0 : No Function 1 : Resistor Brake 2 : AC Brake		0
-------	----------------	---	--	---

0: No function;

1: Resistor brake, use the resistor to consume surplus energy resulting from motor braking, and prevent the drive from trip due to over-voltage in the DC link;

2: AC brake, dissipate surplus energy in the motor core by applying higher voltage to the motor, and prevent the drive from trip due to over-voltage in the DC link. It is important to keep in mind that frequent use of this function will cause an increase in motor temperature;

Par. No.	Name	Range	Unit	Default
P1-92	Max AC Brake Current	0~150	%	100

Defines the maximum permissible current when using AC brake to avoid overheating of motor windings. 100% equals motor current set in P1-06.

Par. No.	Name	Range	Unit	Default
P1-93	AC Brake Gain	1.0~2.0		1.4

Enter AC brake reaction speed. A high value results in faster reaction.

Par. No.	Name	Range	Unit	Default
P1-94	Threshold Voltage for Brake Function	Grid Dependent	V	*

If P1-91 is set to 1, When the DC link voltage exceeds the value of P1-94, resistor brake starts to function and the energy will be rapidly consumed through brake resistor, if the DC link voltage drops back lower than P1-94, the resistor brake function stops.

The following table is the Resistor Brake Threshold Voltage's range and default value which depends on P1-01 Grid Type:

Grid Type	Set Range	Factory Defaults
200~240V	360~395V	385V
380~440V	680~780V	700V
440~480V	750~780V	770V

Par. No.	Name	Range	Unit	Default
P1-95	Resistor Brake Resistance	5~65535	Ω	*

Defines the resistance of the brake resistor.

2.4.3 Parameter Group 2: Digital Terminal Functions

Par. No.	Name	Range	Unit	Default
P2-00	DI Positive-Negative Logic Selection	0~65535		0
P2-02	DI Input Mode	0: : NPN Input 1 : PNP Input		0

P2-00 is used to control the digital input terminal positive or negative logic. Each digital input terminal corresponds to a weight. For example: if you want to set RUN and DI2 terminal as negative logic, set the P2-00 to $1 + 8 = 9$

Terminal	DI4	DI3	DI2	DI1	F/R	RUN
Weight	32	16	8	4	2	1

In NPN Mode, when the digital input selects positive logic, connecting the digital input terminal and GND terminal is ON state (active), disconnecting is OFF state (inactive); When the digital input selects negative logic, connecting the digital input terminal and GND terminal is OFF state (inactive), disconnecting is ON state (active). In PNP Mode, on the contrary.

Note: There are some digital input function is inverse. If the terminal logic is set as negative and the function of the terminal is inverse, then the function of the terminal is positive. For example: When P2-05 Terminal RUN is set to [4] Stop inverse, P2-00 is set to 1 (The logic of terminal RUN is negative), then connect the terminal RUN and GND, function "stop" is active, disconnect the terminal RUN and GND, function "stop" is inactive.

Par. No.	Name	Range	Unit	Default
P2-00	DI Positive-Negative Logic Selection	0~65535		0
P2-01	DO/Relay Positive-Negative Logic Selection	0~65535		0

This parameter is used to control the DO/Relay terminal positive or negative logic. Each DO/Relay terminal corresponds to weight. For example: If you want to set DO1 and Relay1 terminal as negative logic, set the P2-01 to $1 + 4 = 5$

Terminal	Relay2	Relay1	DO2	DO1
Weight	8	4	2	1

Positive logic: When the selected function of DO/Relay terminals is activated, the DO/Relay terminal outputs ON signal, else outputs OFF signal.

Negative logic: When the selected function of DO/Relay terminals is activated, the DO/Relay terminal outputs OFF signal, else outputs ON signal. In

NPN Mode, when the digital input selects positive logic, connecting the digital input terminal and GND terminal is ON state (active), disconnecting is OFF state (inactive); When the digital input selects negative logic, connecting the digital input terminal and GND terminal is OFF state (inactive), disconnecting is ON state (active). In PNP Mode, on the contrary. Note: There are some digital input function is inverse. If the terminal logic is set as negative and the function of the terminal is inverse, then the function of the terminal is positive. For example: When P2-05 Terminal RUN is set to [4] Stop inverse, P2-00 is set to 1 (The logic of terminal RUN is negative), then connect the terminal RUN and GND, function "stop" is active, disconnect the terminal RUN and GND, function "stop" is inactive.

Par. No.	Name	Range	Unit	Default
P2-00	DI Positive-Negative Logic Selection	0~65535		0
P2-01	DO/Relay Positive-Negative Logic Selection	0~65535		0

This parameter is used to control the DO/Relay terminal positive or negative logic. Each DO/Relay terminal corresponds to weight. For example: If you want to set DO1 and Relay1 terminal as negative logic, set the P2-01 to $1 + 4 = 5$

Terminal	Relay2	Relay1	DO2	DO1
Weight	8	4	2	1

Positive logic: When the selected function of DO/Relay terminals is activated, the DO/Relay terminal outputs ON signal, else outputs OFF signal.
 Negative logic: When the selected function of DO/Relay terminals is activated, the DO/Relay terminal outputs OFF signal, else outputs ON signal.

Par. No.	Name	Range	Unit	Default
P2-04	DI Filter Time	2~16	ms	4

It is used to set the software filter time of DI terminal status. If DI terminals are liable to interference and may cause malfunction, increase the value of this parameter to enhance the anti-interference capability. However, increase of DI filter time will reduce the response of DI terminals.

Par. No.	Name	Range	Unit	Default
P2-05	DI Function Selection - Terminal RUN	0 : No Function		10
P2-06	DI Function Selection - Terminal F/R	1 : Reset		11
P2-07	DI Function Selection - Terminal D1	2 : Coast to Stop (Negative Logic)		22
P2-08	DI Function Selection - Terminal D2	3 : Coast to Stop and Reset (Negative Logic)		23
P2-09	DI Function Selection - Terminal D3	4 : Stop (Negative Logic)		24
P2-10	DI Function Selection - Terminal D4	10 : Run 11 : Forward/Reverse Selection 12 : Run in Reverse Direction 13 : Latched run forward 14 : Latched run reverse 15 : Forward Jog 16 : Reverse Jog 20 : Forbid Forward 21 : Forbid Reverse 22 : Preset Value Command Bit 1 23 : Preset Value Command Bit 2 24 : Preset Value Command Bit 3 25 : Preset Value Command Bit 4 26 : Ramp Time Selection Bit 1 27 : Ramp Time Selection Bit 2 30 : Speed UP 31 : Speed DOWN 32 : Counter A 34 : Reset Counter A 35 : Counter B 37 : Rest Counter B 40 : Pulse Input 41 : Switch Set Source 42 : Switch Speed Mode/Torque Mode 50 : External Fault Input 51 : Freeze PID output		25

The parameters are used for selecting various functions in the drive. All digital inputs can be set to the following functions:

- 0: No function, no reaction to signals transmitted to the terminal;
- 1: Reset, reset the drive after a Trip/Alarm;
- 2: Coast to Stop (Negative Logic), disables output, leaving the motor coasting to stop. Terminal logic '0' => coasting stop;
- 3: Coast to Stop and Reset (Negative Logic), the drive resets leaving the motor coasting to stop. Terminal logic '0' => coasting stop;
- 4: Stop (Negative Logic), the drive stops according to selected ramp time. Terminal logic '0' => stop;
- 10: Run, run with a start a start/stop command. Terminal logic '1' = start, logic '0' = stop;
- 11: Forward/Reverse Selection, select the direction of motor shaft rotation. when start signal and running direction selection signal are active, the motor will start reverse; when start signal is active and running direction selection signal is inactive, the motor will start forward; when start signal is inactive, the motor will stop;
- 12: Run in Reverse Direction, start with a reverse direction;
- 13: Latched run forward, run the motor in forward direction with a start command if a valid signal is applied for min. 4ms. The motor stops when [4] Stop (Negative Logic) is activated;
- 14: Latched run reverse, run the motor in reverse direction with a start command if a valid signal is applied for min. 4ms. The motor stops when [4] Stop (Negative Logic) is activated;
- 15: Forward Jog, used for start in forward direction with jog speed, see P0-48;
- 16: Reverse Jog, used for start in reverse direction with jog speed, see P0-48;
- 20: Forbid Forward, when this signal is active, start forward will be forbidden, but start reverse will be allowed;
- 21: Forbid Reverse, when this signal is active, start reverse will be forbidden, but start forward will be allowed;
- 22: Preset Value Command Bit 1, Preset Value Command Bit 1, bit2, bit3, bit4 enables a choice between one of the sixteen multi preset values (see P0-30~P0-45) according to the table below;
- 23: Preset Value Command Bit 2, same as [22];
- 24: Preset Value Command Bit 3, same as [22];
- 25: Preset Value Command Bit 4, same as [22];

Preset Value Command Bit 4	Preset Value Command Bit 3	Preset Value Command Bit 2	Preset Value Command Bit 1	Parameter selected
----------------------------	----------------------------	----------------------------	----------------------------	--------------------

OFF	OFF	OFF	OFF	P0-30
OFF	OFF	OFF	ON	P0-31
OFF	OFF	ON	OFF	P0-32
OFF	OFF	ON	ON	P0-33
OFF	ON	OFF	OFF	P0-34
OFF	ON	OFF	ON	P0-35
OFF	ON	ON	OFF	P0-36
OFF	ON	ON	ON	P0-37
ON	OFF	OFF	OFF	P0-38
ON	OFF	OFF	ON	P0-39
ON	OFF	ON	OFF	P0-40
ON	OFF	ON	ON	P0-41
ON	ON	OFF	OFF	P0-42
ON	ON	OFF	ON	P0-43
ON	ON	ON	OFF	P0-44
ON	ON	ON	ON	P0-45

26: Ramp Time Selection Bit 1;

27: Ramp Time Selection Bit 2; ramp bit1, bit2 are used for selecting one of the four ramps;

Terminal of Ramp bit2	Terminal of Ramp bit1	Parameters selected
OFF	OFF	Ramp1 (P0-51, P0-52)
OFF	ON	Ramp2 (P0-54 P0-55)
ON	OFF	Ramp3 (P0-57, P0-58)
ON	ON	Ramp4 (P0-60, P0-61)

30: Speed Up, when the terminal is activated for less than 400 ms. the resulting reference will be increased by P0-46 Up/Down Value. If the terminal is activated for more than 400 ms, the resulting reference will ramp according to ramp 4 P0-60;

31: Speed Down, like [30] Up;

32: Counter A, to count the pulse number inputted into the terminal;

34: Reset counter A, to clear counter A to “0”;

35: Counter B, like [32] Counter A;

37: Reset counter B, to clear counter B to “0”;

40: Pulse input, select pulse input when using a pulse sequence as either reference or feedback. Scaling is done in par. group P2-5*, the function is available for P2-10 Terminal DI4 only;

41: Switch Set Source, this function is used P0-10 Reference Source Selection option [3]-[5].

42: Switch Speed Mode/Torque Mode, when P0-01 Configuration Mode is set to [2] Torque open loop, torque open loop and speed open loop can be switched via digital input terminal. The terminal is in the OFF state, it is torque open loop; The terminal is in the ON state, it is speed open loop;

50: External Fault Input, when terminal is in ON state, the drive will run as P2-21 specified.

51: Freeze PID output, the Process PID is temporarily stopped and the drive maintains the current frequency.

51: Freeze PID output, the Process PID is temporarily stopped and the drive maintains the current frequency.

Par. No.	Name	Range	Unit	Default
P2-21	Action for DI as External Fault Input	0 : No Action 2 : Stop and Warning 3 : Jog and Warning 4 : Run to Max Speed P5-03 and Warning 5 : Alarm Fault and Trip to stop 6 : Warning		0

The parameter is used for selecting actions when External alarm input is in ON state.

0 : No action;

2 : stop and warning, when External alarm input is in ON state, Drive will stop and report warning “u.76” ;

3 : Jog and warning, when External alarm input is in ON state, Drive will run in Jog speed and report warning “u.76” ;

4 : Running in Max speed and warning, when External alarm input is in ON state, Drive will run in Maximum speed and report warning “u.76” ;

5 : Alarm Fault and Trip to stop, when External alarm input is in ON state, Drive will report alarm “A.76” and trip to stop ;

6 : Only warning, when External alarm input is in ON state, Drive will report warning “u.76” ;

Par. No.	Name	Range	Unit	Default
P2-22	DO Function Selection - Terminal DO1	0~91		0
P2-28	Relay Output Function Selection - RL1	Same as P2-22		10
P2-31	Relay Output Function Selection - RL2	Same as P2-22		10

Set the function which will trigger the Terminal DO1 output.

Terminal DO1 is a programmable multiplex terminal, it can be a high-speed pulse output terminal, also available as a collector's digital output terminal. If P2-60 = 0, DO1 is as a collector's digital output terminal; If P2-60 is not set to 0, DO1 is as a high-speed pulse output terminal.

If terminal DO1 is as collector's digital output terminals, their output function options are the same as relay output P2-28/P2-31.

0: No operation;

- 1: Drive ready, the drive control card has received supply voltage;
- 2: Remote control ready, the drive is ready and is in Remote mode;
- 3: Drive ready/stop, the drive is ready and the drive is not running;
- 4: Drive running, the drive is running;
- 5: Drive running/No warning, the drive is running and no warning is present;
- 6: Run in current range/No warning, the drive is running within the programmed current ranges set in P5-09 and P5-10. No warnings are present;
- 7: Run on reference/No warning, the drive runs at reference speed without warnings;
- 8: Reverse, the drive runs in counter clockwise;
- 10: Alarm, the drive alarms;
- 11: Alarm or warning, an alarm or warning occurs;
- 12: Thermal warning, a thermal warning occurs;
- 13: Ready, no thermal warning, the drive is ready for operation and no over-temperature warning is present;
- 14: Remote ready, no thermal warning, the drive is ready for operation in Remote mode, and no over-temperature warning is present;
- 15: Bus OK, local bus communication is normal;
- 16: Control word bit 11, bit 11 in BUS control word is active;
- 17: Control word bit 12, bit 12 in BUS control word is active;
- 20: Out of current range, output current is outside the range set in P5-09 and P5-10;
- 21: Below current low, output current is lower than set in P5-09;
- 22: Above current high, output current is higher than set in P5-10;
- 23: Out of frequency range, output frequency is outside the range set in P5-11 and P5-12;
- 24: Below frequency low, output frequency is lower than set in P5-11;
- 25: Above frequency high, output frequency is higher than set in P5-12;
- 26: Out of feedback range, feedback is outside the range set in P5-15 and P5-16;
- 27: Below feedback low, feedback is lower than set in P5-15;
- 28: Above feedback high, feedback is higher than set in P5-16;
- 29: Out of reference range, reference is outside the range set in P5-13 and P5-14;
- 30: Below reference low, reference is lower than set in P5-13;
- 31: Above reference high, reference is higher than set in P5-14;
- 40: Drive in Local mode;
- 41: Drive in Remote mode;
- 42: Mech. brake control, enter mechanical brake control signal, see P1-97/P1-98;
- 43: External alarm, the digital input terminal function [50] external alarm input is active;
- 44: Unbalance warning, unbalance occurs;

Par. No.	Name	Range	Unit	Default
P2-29	Relay on Delay Time - RL1	0.00~600.00	s	0.00
P2-30	Relay off Delay Time - RL1	0.00~600.00	s	0.00
P2-32	Relay on Delay Time - RL2	0.00~600.00	s	0.00
P2-33	Relay off Delay Time - RL2	0.00~600.00	s	0.00

These parameters are used to set the relay output turn-on and turn-off delay time, E.g:
When the relay 1 function is satisfied, it delays P2-29 time, then outputs ON.
When the relay 1 function is not satisfied, it delays P2-30 time, then outputs OFF.

Par. No.	Name	Range	Unit	Default
P2-46	Save DI Counter Value at Power down	0 : Save None 1 : Save Counter A 2 : Save Counter B 3 : Save Both Counter A and B		0

This parameter is used to control whether counter A/B's value is saved at power down.

Par. No.	Name	Range	Unit	Default
P2-50	Min Frequency for Pulse Input 1	0.00~P2-51	kHz	0.00

Enter the low frequency corresponding to the low set value in P2-52.

Par. No.	Name	Range	Unit	Default
P2-51	Max Frequency for Pulse Input 1	P2-50~100.00	kHz	50.00

Enter the high frequency corresponding to the high set value in P2-53.

Par. No.	Name	Range	Unit	Default
P2-52	Set Value/Feedback Value Versus Min Frequency for Pulse Input 1	-200.00~200.00	%	0.00

Enter low set value corresponding to value in P2-50.

Par. No.	Name	Range	Unit	Default
P2-53	Set Value/Feedback Value Versus Max Frequency for Pulse Input 1	-200.00~200.00	%	100.00

Enter high set value corresponding to value in P2-51.

Par. No.	Name	Range	Unit	Default
P2-54	Pulse input 1 Filter Time	1~1000	ms	100

Enter the pulse filter time, the low pass filter reduces the influence on and dampens the oscillations on the feedback signal from the control.
Note: when P2-10 set to [40]Pulse input, Terminal DI4 used as pulse input 1.

Enter the pulse filter time, the low pass filter reduces the influence on and dampens the oscillations on the feedback signal from the control.
Note: when P2-10 set to [40]Pulse input, Terminal DI4 used as pulse input 1.

Par. No.	Name	Range	Unit	Default
----------	------	-------	------	---------

P2-60	Pulse output 1 function selection	0 ~ 30		0
-------	-----------------------------------	--------	--	---

Terminal DO1(Pulse output 1) pulse output function are described as below:

Option	Function	Scale
0	Digital output	DO1 is as a collector's digital output terminal
1	Output frequency	In torque open loop: 0% = 0, 100% = P5-08 In speed open loop mode: 0% = 0, 100% = P0-16
2	Output current	0% = 0, 100% = P9-16
3	Output Power	0% = 0, 100% = P1-03
4	Motor Speed	0% = 0, 100% = P1-07
5	Output voltage	0% = 0, 100% = P1-04
10	Set Value	If P0-15 = 0, then 0% = 0, 100% = P0-16; If P0-15 = 1, then 0% = -P0-16, 100% = P0-16;
11	Feedback	
13	Set Value from Bus	
14	Pulse input 1 input frequency	0% = P2-50, 100% = P2-51
15	Terminal AI1 input value	0% = P3-03 or P3-05, 100% = P3-04 or P3-06
16	Terminal AI2 input value	0% = P3-12 or P3-14, 100% = P3-13 or P3-15
20	DC link voltage	0% = 0V, 100% = 1000V
30	Output Torque	0% = 0N·m, 100% = P1-08

Par. No.	Name	Range	Unit	Default
P2-61	Min Frequency for Pulse Output 1	0.00~P2-62	kHz	0.00
P2-62	Max Frequency for Pulse Output 1	P2-61~100.00	kHz	50.00
P2-63	Function Value Versus Min Frequency for Pulse Output 1	0.00~200.00	%	0.00
P2-64	Function Value Versus Max Frequency for Pulse Output 1	0.00~200.00	%	100.00

P2-61 and P2-62 are used to set minimum and maximum frequency of the pulse output; P2-63 and P2-64 are used to set minimum and maximum value corresponding to minimum and maximum frequency.

For example: In speed open loop mode, Set P0-16 = 50.0, P2-60 = 1 (0% = 0Hz, 100% = 50Hz), P2-61 = 2kHz, P2-62 = 10kHz, if P2-63 = 0.00% (0Hz), P2-64 = 100.00% (50Hz), then the relationship between the output frequency and terminal DO1 pulse output frequency is shown below:

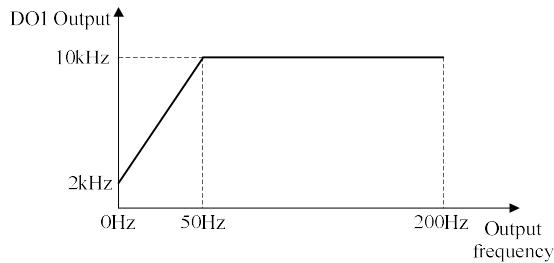

If P2-63 = 80.00% (40Hz), P2-64 = 10.00% (5Hz), then the relationship between the output frequency and DO1 pulse output frequency is shown below:



Par. No.	Name	Range	Unit	Default
P2-70	Encoder Resolution	0~4096		1024

This parameter is used to set the number of pulses per revolution of the encoder.

Par. No.	Name	Range	Unit	Default
P2-71	Encoder Rotation Direction	0: Forward 1: Reverse		0

This parameter is used to set the phase sequence of the incremental encoder AB signal.

2.4.4 Parameter Group 3: Analogue Terminal Functions

Par. No.	Name	Range	Unit	Default
P3-00	Signal Type - Terminal A11	0 : Analogue Voltage 1 : Analogue Current		0

Select the signal type to be present on analog input A11.

Par. No.	Name	Range	Unit	Default
P3-01	Terminal A11 Filter Time	0.01~10.00	s	0.01

Enter the terminal A11 filter time. This is a first-order digital low pass filter for suppressing electrical noise in terminal A11. A high time constant value improves dampening but also increases the time delay through the filter.

Par. No.	Name	Range	Unit	Default
P3-02	Zero Voltage Dead Band - Terminal A11	0.0~20.00	V/mA	0.00

Set the dead-band of A11 at 0 speed. When analog input A11 ref. low and ref. high have opposite signs, there must be a set point that corresponding to an analogue value equals 0. In order to prevent the set point jitter at zero point due to analog interference, this parameter should be set properly.

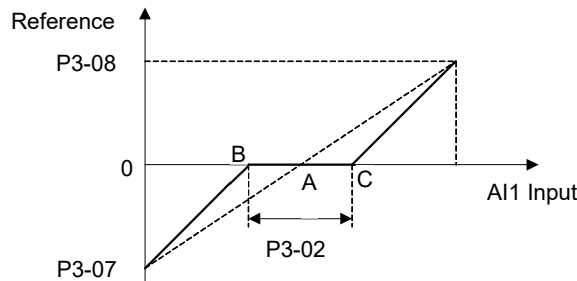

Point A as shown in the figure is the analog value that corresponds to a setpoint that equals 0. It is calculated via analog low, high values and low, high reference values. After set terminal A11 zero dead band, $U_{AB}=U_{AC}=P3-02/2$. If the A11 input is between B and C, the A11 reference is 0.

Par. No.	Name	Range	Unit	Default
P3-03	Min Input Voltage - Terminal A11	0.00~P3-04	V	0.00
P3-04	Max Input Voltage - Terminal A11	P3-03~10.00	V	10.00
P3-05	Min Input Current - Terminal A11	0.00~P3-06	mA	0.00
P3-06	Max Input Current - Terminal A11	P3-05~20.00	mA	20.00
P3-07	Set Value/Feedback Value Versus Min Input -Terminal A11	-200.00~200.00	%	0.00
P3-08	Set Value/Feedback Value Versus Max Input -Terminal A11	-200.00~200.00	%	100.00

P3-03 is used to set min voltage input; P3-05 is used to set min current input; The min voltage and current analog input corresponds to the set/feedback value set in P3-07.

P3-04 is used to set max voltage input; P3-06 is used to set max current input; The max voltage and current analog input corresponds to the set/feedback value set in P3-08.

There are 4 kinds of curves between terminal A11 input voltage/current and its corresponding set/feedback value:

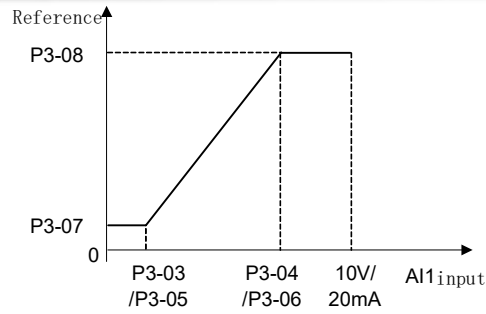

$$P3-07 < P3-08 \text{ and } P3-07 \geq 0$$

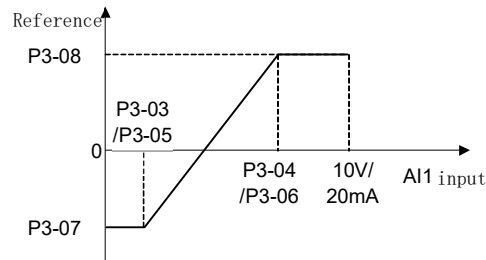

$$P3-07 < P3-08 \text{ and } P3-07 < 0$$

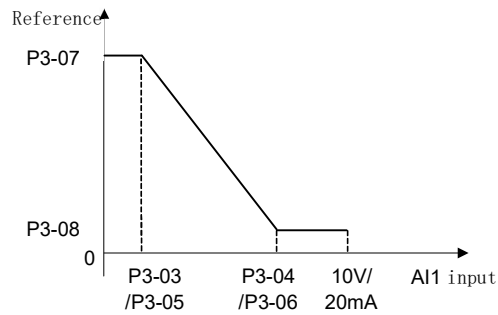

$$P3-07 > P3-08 \text{ and } P3-08 \geq 0$$

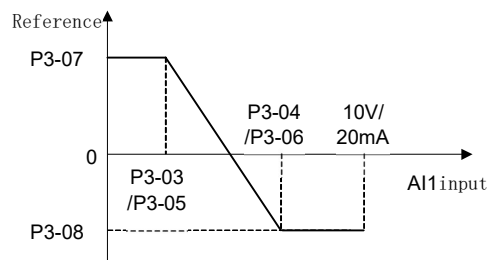

$$P3-07 > P3-08 \text{ and } P3-08 < 0$$

Terminal AI1 set/feedback value calculated as follows:

If $P3-03 \leq AI1 \text{ Input} \leq P3-04$,

AI1 set/feedback Value = $((P3-08 - P3-07) \div (P3-04 - P3-03) \times (AI1 \text{ input} - P3-03) + P3-07) \times P0-16$;

If $AI1 \text{ Input} < P3-03$, AI1 set/feedback Value = $P3-07 \times P0-16$;

If $AI1 \text{ Input} > P3-04$, AI1 set/feedback Value = $P3-08 \times P0-16$;

Note: Above formulas are for voltage input. If it is a current input, P3-03 and P3-04 use P3-05 and P3-06 instead respectively.

Par. No.	Name	Range	Unit	Default
P3-09	Signal Type - Terminal AI2	0 : Analogue Voltage 1 : Analogue Current		1
P3-10	Terminal AI2 Filter Time	0.01~10.00	s	0.01

P3-11	Zero Voltage Dead Band - Terminal AI2	0.0~20.00	V/mA	0.00
P3-12	Min Input Voltage - Terminal AI2	0.00~P3-13	V	0.00
P3-13	Max Input Voltage - Terminal AI2	P3-12~10.00	V	10.00
P3-14	Min Input Current - Terminal AI2	0.00~P3-15	mA	0.00
P3-15	Max Input Current - Terminal AI2	P3-14~20.00	mA	20.00
P3-16	Set Value/Feedback Value Versus Min Input -Terminal AI2	-200.00~200.00	%	0.00
P3-17	Set Value/Feedback Value Versus Max Input -Terminal AI2	-200.00~200.00	%	100.00

The usage of terminal AI2 is like terminal AI1.

Par. No.	Name	Range	Unit	Default
P3-48	Analogue Live Zero Timeout Time	1~99	s	10

Live Zero Time-out Function is used for analog input signal detection. To activate the Live Zero Timeout Function, if voltage input is selected, then the low input voltage (P3-03, P3-12) settings must be greater than 1V; if current input is selected, the low input current (P3-05, P3-14) settings must be greater than 2mA or more. If the analog input signal is lower than 50% of the settings of parameters of P3-03, P3-05, P3-12, P3-14, and lasts longer than the settings of P3-48 Live Zero Timeout Time, this feature takes effect.

If the analog input signal is back to normal within the delay time, then reset the timer.

Diagram of Live Zero Timeout Function is shown below:

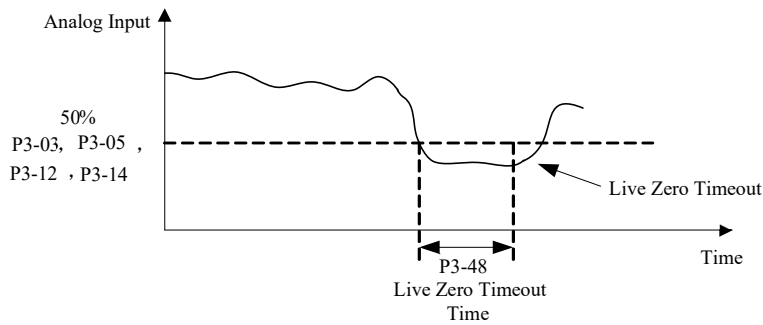

Par. No.	Name	Range	Unit	Default
P3-49	Live Zero Timeout Function	0 : No Action 2 : Stop and Warning 3 : Jog and Warning 4 : Run at Max Speed P5-03 and Warning 5 : Alarm Fault and Trip to stop		0

Select the live zero time-out function.

0: No function;

2 : Stop and warning, Drive stop and report warning “u.57” ;

3 : Jog and warning, Drive will run in Jog speed and report warning “u.57” ;

4 : Run at Max Speed P5-03 and Warning, Drive will run in P5-03 Maximum speed and report warning “u.57” ;

5 : Alarm Fault and Trip to stop, Drive will report alarm “A.57” and trip to stop.

Par. No.	Name	Range	Unit	Default
P3-50	Signal Type - Terminal AO1	0: 0-20mA 1: 4-20mA 3: 0-10V		3

Select the output signal type to be present on analog output AO1.

Par. No.	Name	Range	Unit	Default
P3-51	Output Function Selection- AO1	0~30		0

Select choices for the analog output AO1

Option	Function	Scale
0	No function	
1	Output frequency	In torque open loop: 0% = 0, 100% = P5-08 In speed open loop mode: 0% = 0, 100% = P0-16
2	Output current	0% = 0, 100% = P9-16
3	Output Power	0% = 0, 100% = P1-03
4	Motor Speed	0% = 0, 100% = P1-07
5	Output voltage	0% = 0, 100% = P1-04
10	Set Value	If P0-15 = 0, then 0% = 0, 100% = P0-16; If P0-15 = 1, then 0% = -P0-16, 100% = P0-16;

11	Feedback Value	
13	Set Value from Bus control	
14	Pulse input 1 input frequency	0% = P2-50, 100% = P2-51
15	Terminal AI1 input value	0% = P3-03 or P3-05, 100% = P3-04 or P3-06
16	Terminal AI2 input value	0% = P3-12 or P3-14, 100% = P3-13 or P3-15
20	DC link voltage	0% = 0V, 100% = 1000V
30	Output Torque	0% = 0N·m, 100% = P1-08

Par. No.	Name	Range	Unit	Default
P3-52	Value Versus Min Output - AO1	0.00~200.00	%	0.00
P3-53	Value Versus Max Output - AO1	0.00~200.00	%	100.00
P3-54	Min Output Voltage/Current - AO1	0.00~P3-55		0.00 /4.00
P3-55	Max Output Voltage/Current - AO1	P3-54~10.00/20.00		10.00 /20.00

Scale minimum/maximum output of selected analog signal at terminal AO1 as percentage of minimum/maximum signal value.
 For example: In speed open loop mode, set P0-16 = 50.0, P3-50 = 3 (0~10V), P3-50 = 1 (Output frequency 0% = 0.0Hz, 100% = 50.0Hz), P3-52 = 0.00% (0.0Hz), P3-53 = 100.00% (50.0Hz), P3-54 = 2V, P3-55 = 8V, the relationship between the output frequency and AO1 output is shown below:

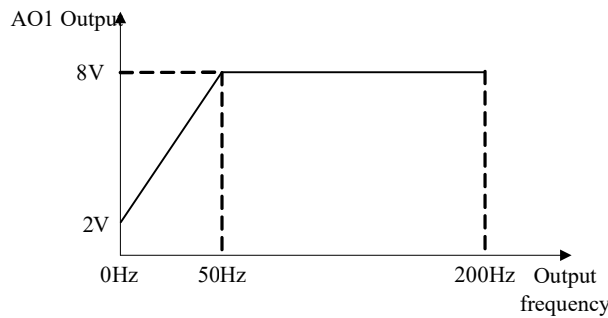

If P3-52 = 80.00% (40Hz), P3-53 = 10.00% (5Hz), then the relationship between the output frequency and AO1 output is shown below:

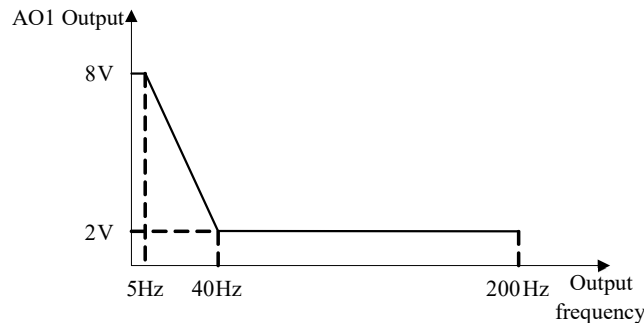

Par. No.	Name	Range	Unit	Default
P3-68	Min Set Value from Keypad	-200.00~200.00	%	0.00
P3-69	Max Set Value from Keypad	-200.00~200.00	%	100.00

These parameters are used to set the minimum/maximum set value from Keypad Up/Down key or potentiometer.

Par. No.	Name	Range	Unit	Default
P3-90	Enable Analogue Input as Digital Input	0 : Keep as Analogue Inputs 1 : Enable Analogue Inputs as Digital Inputs		0
P3-91	Function Selection for AI1 as DI	Same as P2-05		0
P3-92	Function Selection for AI2 as DI	Same as P2-05		0

In some cases, customers need more DI terminals but they do not need AI terminal. With these group of parameters, customers can use terminal AI1/AI2 as DI terminal. Please be aware of that, in SSI800, AI1 and AI2 must be set to digital inputs or analogue inputs at the same time.

2.4.5 Parameter Group 4: Process PID and Other Controllers

Par. No.	Name	Range	Unit	Default
P4-00	Process PID Feedback Source	0: No function 1: Terminal AI1 2: Terminal AI2 5: Pulse input 1 20: Bus Communication		0

Select source of feedback signal.

Par. No.	Name	Range	Unit	Default
P4-01	Process PID Set Source	0: No function 1: Terminal AI1 2: Terminal AI2 5: Pulse input 1 10: Preset value 0+UP/DOWN 11: Multi preset value 20: Bus communication 30: Keypad		0

Select process PID reference source.

- 0: No function;
- 1: Terminal AI1, use analogy input AI1 as reference source, see P3-0*;
- 2: Terminal AI2, use analogy input AI2 as reference source, see P3-1*;
- 5: Pulse input 1, use pulse input DI4 as reference source, see P2-5*;
- 10: Present value 0 + Up/Down, use present value 0 and Up/Down, see P0-30;
- 11: Multi present value, see P0-30~P0-45;
- 20: Bus communication, use bus reference as reference source;
- 30: Keypad, use Keypad Up/Down key or potentiometer as reference source, see P3-68/P3-69;

Par. No.	Name	Range	Unit	Default
P4-02	Fiducial Value for Process PID Set/Feedback	0.0~3000.0		50.0

This parameter is set as the fiducial value of 100% set or feedback for process PID control.

Par. No.	Name	Range	Unit	Default
P4-04	Process PID Control Logic: Positive/Negative	0 : Positive 1 : Negative		0

- 0: Positive, reduce/increase the PID output if the feedback value is larger/lower than set value;
- 1: Negative, reduce/increase the PID output if the feedback value is lower/larger than set value;

Par. No.	Name	Range	Unit	Default
P4-05	Process PID Anti Windup	0: Disable 1: Enable		0

In case the PID output has reaches the limit but the error between set value and feedback value still exists in same sign, if the integrator continues to work then the result of integrator will be very high. It will take very long time for the PID controller to response to the error sign change e.g. from positive to negative. This ruins the control performance in a lot of application. Customer can use this function to avoid the problem.

- 0: Disable, continue regulation of a given error even when the PID output reaches to its limit;
- 1: Enable, ceases regulation of a given error when the PID output reaches to its limit;

Par. No.	Name	Range	Unit	Default
P4-06	Cut-in Frequency for Process PID Speed Mode	0.0~200.0	Hz	0.0

Given a start command, the product will ramp from 0 to P4-06 in speed open control first. When the speed reaches to P4-06, the control will switch over to Process PID control. The principle is described as below:

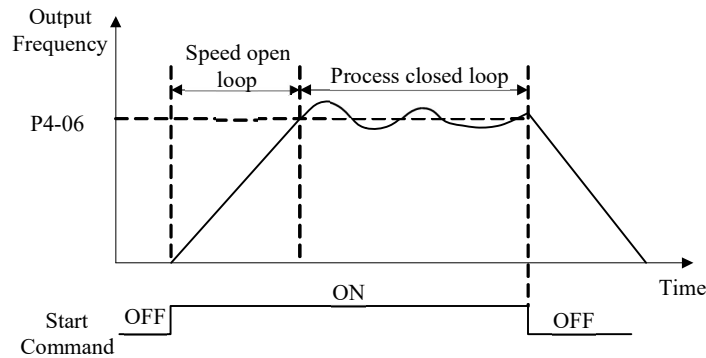

Par. No.	Name	Range	Unit	Default
P4-07	Proportional Gain - Process PID 1	0.00~10.00		0.01

Enter the PID proportional gain. The proportional gain multiplies the error between the set value and the feedback value.

Attention: This function is disabled when it is set to "0".

Par. No.	Name	Range	Unit	Default
P4-08	Integral Time - Process PID 1	0.01~655.35	s	655.35

Enter the PID integral time. The integrator provides an increasing gain at a constant error between the set value and the feedback value. The integral time is the time needed by the integrator to reach the same gain as the proportional gain.

Par. No.	Name	Range	Unit	Default
P4-09	Differentiating Time - Process PID 1	0.00~10.00	s	0.00

Enter the PID differentiation time. The differentiator does not react to a constant error, but provides a gain only when the error changes. The shorter the PID differentiation time, the stronger the gain from the differentiator.

Par. No.	Name	Range	Unit	Default
P4-13	Process PID Differential Limit	1.0~50.0		5.0

Enter a limit for the differentiator output.

Par. No.	Name	Range	Unit	Default
P4-14	Error Tolerance Limit to Enable Process PID	0.0~200.0	%	0.1

When the error between the set value and feedback value is less than the set value of this parameter, the process PID control stops. The way how PID control stops or restarts is controlled by P4-15.

Par. No.	Name	Range	Unit	Default
P4-15	Process PID Out/In Mode to Error Tolerance	0: Mode 0 1: Mode 1 2: Mode 2		0

0: Mode 0, if the absolute value of the error \geq P4-14, PID is enabled; if the absolute value of the deviation $<$ P4-14, PID is disabled, PID output freezes;

1: Mode 1, if the absolute value of the error \geq P4-14, PID is enabled. If error $>$ 0, use error + P4-14 as error for PID calculation; If error $<$ 0, use error - P4-14 as error for PID calculation; if the absolute value of the error $<$ P4-14, PID is enabled as normal;

2: Mode 2, if the absolute value of the error \geq P4-14, PID is enabled, but the output of I part is frozen; if the absolute value of the error $<$ P4-14, PID is enabled as normal;

Par. No.	Name	Range	Unit	Default
P4-18	Process PID Output Low Limit	-100.00~100.00	%	0.00
P4-19	Process PID Output High Limit	-100.00~100.00	%	100.00

These parameters are used to set process PID controller output low/high limit, 100% corresponds to P5-03 in speed mode.

Par. No.	Name	Range	Unit	Default
P4-22	Process PID Integral Output Low Limit	-100.00~100.00	%	0.00
P4-23	Process PID Integral Output High Limit	-100.00~100.00	%	100.00

This group of parameters are used to set the process PID controller integral output high and low limits.

Par. No.	Name	Range	Unit	Default
P4-30	Speed PID Proportional Gain	0.000~1.000		0.010
P4-31	Speed PID Integral Time	2.0~2000.0	ms	8.0
P4-32	Speed PID Differentiation Time	0.0~200.0	s	30.0

Speed closed loop PID parameters.

Par. No.	Name	Range	Unit	Default
P4-33	Speed PID Differential Limit	1.000~20.000		5.000

Set a limit for the differentiator output.

Par. No.	Name	Range	Unit	Default
P4-34	Speed PID Speed Signal Filter Time	1.0~100.0		10.0

Set a time constant for the speed signal lowpass filter. Too long filter time reduce the dynamic performance.

Par. No.	Name	Range	Unit	Default
P4-40	Torque PI Proportional Gain	0~500	%	100

Enter the proportional gain value for the torque controller. Selection of a high value makes the controller react faster. Too high setting may lead to control instability.

Par. No.	Name	Range	Unit	Default
P4-41	Torque PI Integration Time	0.002~2.000	s	0.020

Enter the integration time for the torque controller. Selection of a low value makes the controller react faster. Too low setting may lead to control instability.

Par. No.	Name	Range	Unit	Default
P4-51	PM Current Limit Controller Feedforward Gain	0~400	%	100

This parameter only works in PM motor control. P4-51 together with P4-52, P4-53 and P4-54 works in the current limit controller when the motor current reaches to current limit level set in P5-07.

Par. No.	Name	Range	Unit	Default
P4-52	Proportional Gain - Current Limit Controller	0~500	%	100
P4-53	Integration Time - Current Limit Controller	0.000~2.000	s	0.020
P4-54	Filter Time - Current Limit Control	0.1~100.0	ms	10.0

These parameters are used for the current limit controller which will be triggered if the motor current reaches to P5-07.

Par. No.	Name	Range	Unit	Default
P4-61	Isd PI Control Bandwidth	10~200	Hz	30
P4-62	Isd PI Control Damping Coefficient	1~200		100
P4-63	Isd Load Compensation Coefficient	0.1~1.0		0.5
P4-64	Isq PI Control Bandwidth	0.01~1.00	Hz	0.03
P4-65	Isq PI Control Damping Coefficient	1~200		1

This group of parameters are valid only when P0-02 is equal to [2] vector 2. They are current loop adjustment parameters for vector control, and generally do not need to be adjusted.

2.4.6 Parameter Group 5: Limitation, Protection and Failure Detection

Par. No.	Name	Range	Unit	Default
*P5-02	Motor Low Speed Limit	0.0~590.0	Hz	0.0
*P5-03	Motor High Speed Limit	0.0~590.0	Hz	65.0

P5-02 sets the low limit for Motor Speed. The Motor Low Speed Limit must not exceed the Motor Speed High Limit in P5-03. P5-03 sets the high limit for Motor Speed. The Motor High Speed Limit must exceed the Motor Low Speed Limit in P5-02. Please be noticed that, P5-02 and P5-03 are used to limit the set value.

Par. No.	Name	Range	Unit	Default
P5-04	Torque Limit at Motor Mode	0~1000	%	160
P5-05	Torque Limit at Generator Mode	0~1000	%	160

These parameters limit the torque on the shaft to protect the mechanical installation. 100% equals motor rated torque set in P1-06. If the motor torque is bigger than P5-04/P5-05, the product will report “u.51”.

Par. No.	Name	Range	Unit	Default
P5-06	Source Selection for Speed Limit at Torque Mode	0 : No Function 1 : Input From Terminal A11 2 : Input From Terminal A11 5 : Pulse Input 1 10: Preset Value 0 + UP/DOWN 11: Multi Preset Values 20 : Bus Communication 30 : Keypad		0

This parameter is to select how to define the limit of the speed at torque control mode. If the parameter is set to [0], the speed limit value is defined by P5-08. For other options, please refer to P0-11

Par. No.	Name	Range	Unit	Default
P5-07	Max Current Limit	0~300	%	*

This parameter is used to set the output current limit, 100% equals to P1-06 rated motor current. If the output current reaches the P5-07, the product will report u.50 warning and current limit controllers start to function with the controller set in P4-5*.

Par. No.	Name	Range	Unit	Default
*P5-08	Max Output Frequency Limit	0.0~400.0	Hz	65

Provides a final limit on the output frequency of the product. Please be aware of that this parameter limit the final stator frequency applied to the motor.

Par. No.	Name	Range	Unit	Default
P5-09	Threshold for Low Current Warning	0.00~P9-16	A	0.00
P5-10	Threshold for High Current Warning	0.00~ P9-16	A	*

When the motor current falls below P5-09 or exceeds P5-10, a signal can be produced on relays or terminal DO. See [20] Out of current range, [21] Below current low and [22] Above current high in P2-22/28/31.

Diagram of Warning Current Low and Warning Current High are shown below:

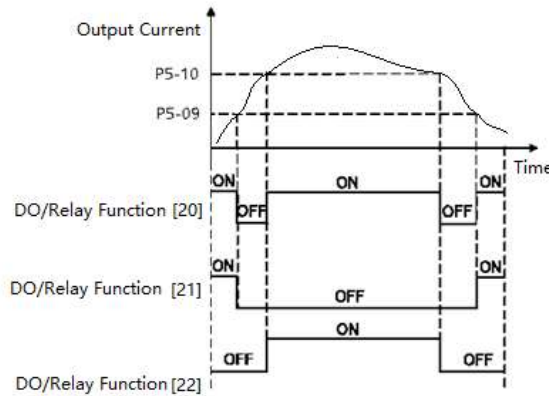

Par. No.	Name	Range	Unit	Default
P5-11	Threshold for Low Speed Warning	0.0~400.0	Hz	0.0
P5-12	Threshold for High Speed Warning	0.1~400.0	Hz	65.0

When the motor frequency falls below P5-11 or exceeds P5-12, a signal can be produced on relays or terminal DO. See [23] Out of frequency range, [24] Below frequency low and [25] Above frequency high in P2-22/28/31. Diagram of Warning Frequency Low and Warning Frequency High are shown below:

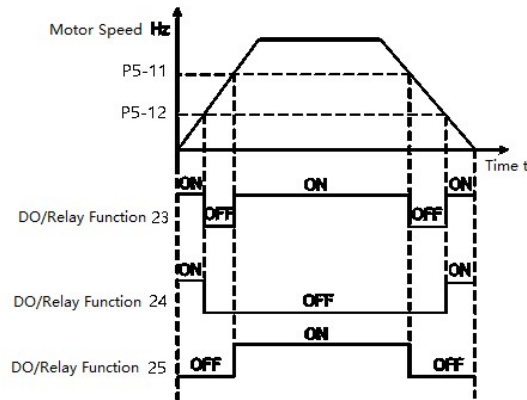

Par. No.	Name	Range	Unit	Default
P5-13	Threshold for Low Set Value Warning	-200.00~200.00	%	0.00
P5-14	Threshold for High Set Value Warning	-200.00~200.00	%	100.00

When the actual set value falls below P5-13 or exceeds P5-14, a signal can be produced on relays or terminal DO. 100% equals to value set in P0-16 in speed control mode, P1-08 in torque control mode. See functions [29], [30] and [31] in P2-20/31/40.

Note: These parameters work on the final set value decided by P0-11~P0-14, not on the set value for PID inputs.

Par. No.	Name	Range	Unit	Default
P5-15	Threshold for Low Feedback Warning	-200.00~200.00	%	0.00
P5-16	Threshold for High Feedback Warning	-200.00~200.00	%	100.00

When the feedback falls below P5-15 or exceeds P5-16, a signal can be produced on relays or terminal DO. 100% equals value set in P4-02. See function [26], [27] and [28] in P2-22/28/31.

Note: These parameters only work on the feedback for PID as selected by P4-00.

Par. No.	Name	Range	Unit	Default
*P5-17	Enable Motor Phase Loss Protection	0 : Disable 1 : Enable		1

If select [0] disable the motor phase loss protection, in case there is the failure, the motor can only be possible to protect by over current protection. It may damage the motor and the customer get a wrong information. Normally it's not recommended to select [0]. But in case the product power size is much bigger than that of the motor and there is unbalance inside the motor, selecting [0] could avoid false alarm of motor phase loss.

Par. No.	Name	Range	Unit	Default
*P5-18	Enable Current Limit/Torque Limit Warning	0 : Disable 1 : Enable		1

This parameter is used to control whether the drive reports u.50/u.51 warning or not when the motor torque exceeds P5-04/P5-05 or the output current exceeds P5-07.

Note: Even if you select disable the warning, current limit/torque limit controller still works.

Par. No.	Name	Range	Unit	Default
P5-19	Motor Speed Feedback Loss Function	0 : No Function 3 : Jog and Warning 4 : Run to Max Speed P5-03 and Warning 5 : Alarm Fault and Trip to stop 11 : Switch to Speed Sensor less Mode		5

In case a control mode with motor speed feedback is selected, this parameter is used to define the action when the speed feedback signal fails.

0: No function, the product will continue to run with the wrong speed feedback.

3: Jog and warning, the product will run with the jog speed and report warning u.61

4: Run to max speed, the product will run to max speed defined by P5-03 and report warning u.61

5: Alarm fault and trip to stop, the product will report alarm A.61 and trip to stop

11: Switch to speed sensor less mode, the product will switch to speed sensor less mode automatically and report warning u.61

Par. No.	Name	Range	Unit	Default
P5-20	Speed Error for Speed Feedback Loss Detection	1~600	RPM	300
P5-21	Time for Speed Feedback Loss Detection	0.00~60.00	S	0.05

These parameters are used to determine how the product judge whether the speed feedback gets wrong. If the error between feedback speed and the set speed exceed P5-20 continuously for time longer than P5-21, the speed feedback loss function P5-19 will be triggered. Please consider the set of parameters P4-3* to avoid false actions.

Par. No.	Name	Range	Unit	Default
P5-22	Threshold for Communication with CU Timeout	0.10 ~ 60.00	S	1.00

If the Power Unit fails to get correct communication telegrams from the Control Unit continuously for time longer than P5-22, the action defined by P5-23 will be triggered.

Par. No.	Name	Range	Unit	Default
P5-23	Communication with CU Timeout Function	0 : No Function 2 : Stop and Warning 3 : Jog and Warning 4 : Run to Max Speed P5-03 and Warning 5 : Alarm Fault and Trip to stop 6 : Warning		5

This parameter defines the action in case the Power Unit fails to get communication telegrams from the Control Unit for time longer than defined in P5-22.

0: No Function, the product will continue to run with the latest received commands

2: Stop and Warning, the product will stop and report warning u.03

3: Jog and Warning, the product will run with jog speed and report warning u.03

4: Run to Max Speed P5-03 and Warning, the product will run to the max speed P5-03 and report warning u.03

5: Alarm Fault and Trip to stop, the product will report alarm A.03 and trip to stop.

6: Warning, the product will continue to run with the latest received commands and report warning u.03

Par. No.	Name	Range	Unit	Default
P5-26	Motor Thermal Protection Function	0 : No Function 1 : ETR Warning 2 : ETR Alarm Fault 3 : ETR Warning for Self-cooled Motor 4 : ETR Alarm Fault for Self-cooled Motor		0

The product can afford thermal protection function via a calculation (ETR = Electronic Terminal Relay) of the thermal load of the motor. The calculated thermal load is based on the motor current and motor speed according to the set in P5-27 and P5-28.

0: No function, there is no motor thermal protection;

1: ETR warning, if calculated thermal load exceeds the upper limit, the product reports warning.49

2: ETR alarm fault, if calculated thermal load exceeds the upper limit, the product reports alarm A.49 and trip to stop

3: ETR warning (Self-cooling mode)

4: ETR trip (Self-cooling mode)

[3] and [4] are similar as [1] and [2], but [3] and [4] are for motors without cooling fan. And the calculated thermal load increases faster, more sensitive to motor speed and it takes longer time to clear the calculated thermal load when the current of the motor drops.

Par. No.	Name	Range	Unit	Default
P5-27	Motor Overload Protection Time	1~60	min	2
P5-28	Threshold for Motor Overload Protection	100~160	%	150

When ETR function is used, if motor current exceeds P1-06 rated motor current * P5-28 Threshold for Motor Overload Protection for duration exceeding P5-27 motor overload protection time, the product will trigger motor overload warning or alarm as defined in P5-26.

Motor overload protection is based on an inverse time integral calculation. The relationship between overload current and protection time (corresponding to P5-27) is described as below:

Par. No.	Name	Range	Unit	Default
P5-28+0%	100%	P5-28+30%	20%	P5-28+0%
P5-28+6%	50%	P5-28+36%	18%	P5-28+6%
P5-28+12%	33%	P5-28+42%	17%	P5-28+12%
P5-28+18%	29%	P5-28+48%	16%	P5-28+18%
P5-28+24%	21%	P5-28+54%	14%	P5-28+24%

The table above assumes the motor runs at rated speed, below is the table for correction factor according to the motor speed (the real protection time should be divided by the correction factor).

Motor Speed (percent of P1-05)	Correction Factor	Motor Speed (percent of P1-05)	Correction Factor
0-12.5%	2.1	100%-112.5%	1
12.5%-25%	2.1	112.5%-125%	1.05
25%-37.5%	1.67	125%-137.5%	1.12
37.5%-50%	1.45	137.5%-150%	1.2
50%-62.5%	1.31	150%-162.5%	1.31
62.5%-75%	1.2	162.5%-175%	1.45
75%-87.5%	1.12	175%-187.5%	1.67
87.5%-100%	1.05	187.5%-Max.	2.1

For example, set P5-27 = 10, P5-28 = 120%, run at rated frequency, current is 132% rated motor current, protection time is $10 \times 33\% = 3.3$ minutes. If the operating frequency is 30Hz (60% of rated frequency), the protection time is $3.3 \div 1.31 = 2.52$ minutes.

Note: It is necessary to correctly set the P5-28 motor overload protection factor according to the actual overload capacity of the motor. If this parameter is set too large, it may happen that the motor is overloaded but the product cannot protect it in time!

Par. No.	Name	Range	Unit	Default
P5-29	Function at Mains Phase Loss	0 : No Action 1 : Only Warning 2 : Trip to stop and Alarm Fault (Heavy Load) 3 : Trip to stop and Alarm Fault (Mid Load) 4 : Trip to stop and Alarm Fault (Light Load)		3

This parameter is used to select the action in case mains phase loss.

0: No action. The product will have no protection, it's not recommended normally

1: Only warning. The product will report warning u.26 in case mains phase loss with load applied and the product will continue to run.

2: Trip to stop and alarm fault (Heavy load). The product will report alarm A.26 and trip to stop. But the product can detect the mains phase loss only when the load is full and continues for certain period time (normally in minutes)

3: Trip to stop and alarm fault (Mid load). The product will report alarm A.26 and trip to stop. But the product can detect the mains phase loss only when certain percentage of rated load is applied (normally 30%~60%)

4: Trip to stop and alarm fault (Light load). The product will report alarm A.26 and trip to stop. In this option, the protection can be triggered very fast when the product starts to ramp the motor.

Par. No.	Name	Range	Unit	Default
P5-30	Alarm/Fault Lock Handling	0 : Not Lock, Alarm/Fault Resettable without Re-Power On 1 : Lock, Alarm/Fault Lock Resettable only after Re-Power On		1

In default setup, the locked alarms/faults (refer to 2.6.1) cannot be reset unless power-down and power-on cycle is implemented. In some special cases, customer wants to reset the locked alarms/faults with a power-down and power-up operation, then customer can set P5-30 to 0. Please be very careful to so and consider all the safety issues.

Par. No.	Name	Range	Unit	Default
P5-31	Delay Time to Alarm Current Limit Fault	0~60	S	60

When the output current reaches the current limit level set in P5-07, a warning u.50 is triggered. When the current limit warning has been continuously present for the period specified in this parameter, the product will trip to stop and report alarm A.50. If P5-31 = 60, the alarm and trip function is disabled.

Par. No.	Name	Range	Unit	Default
P5-32	Delay Time to Alarm Torque Limit Fault	0~60	S	60

When the output torque reaches the torque limit level set in P5-04/P5-05, a warning u.51 is triggered. When the torque limit warning has been continuously present for the period specified in this parameter, the product will trip to stop and report alarm A.51. If P5-32 = 60, the alarm and trip function is disabled.

Par. No.	Name	Range	Unit	Default
P5-33	Action at Warning	0 : Trip to stop and Alarm Fault directly 1 : Warning and Re-catch Motor after Failure Disappear		1

This parameter is to define the action when warning like over voltage, undervoltage and over current at which the product needs to coast the motor temporary but the failure can disappear and the product needs to recover the control of the motor.

0 : Trip to stop and Alarm Fault directly, at failure, the warning will turn into alarm directly and trip to stop.

1 : Warning and Re-catch Motor after Failure Disappear, at failure the product will report warning and coast the motor first, when the failure disappears, the product will try to re-control the motor.

Par. No.	Name	Range	Unit	Default
P5-34	Method to Re-catch Motor at Warning	0 : Speed Track (IM/PM) and Angle Track (Fly start) 1 : Direct Re-catch		0

This parameter defines how the product re-control the motor when P5-33 is set to [1]

0 : Speed Track (IM/PM) and Angle Track (Fly start). The product will track the speed (for both IM and PM) and angle (only for PM) of the motor first and re-control the motor with the tracked speed/angle. If it fails to track the speed/angle, the it will start the motor form 0 speed.

1 : Direct Re-catch. The product will assume there is no speed change in the motor during the coasted period, and re-control the motor based on the voltage command when the warning is triggered.

Note: [1] is only for IM motor. For PM motor, it will work as [0] no matter what is set in P5-34

2.4.7 Parameter Group 6: Keypad Operation and Display

Par. No.	Name	Range	Unit	Default
P6-03	Customer Defined Value for 0 Speed	0.0~6553.5		0.00
P6-04	Customer Defined Value for Max Speed	0.0~6553.5		100.00

It is possible to customize a readout value in the product. Custom readout value is linear proportional to speed, it is stored in parameter P9-48.

The calculation of Custom Readout Value (P9-48) is shown below:

$$P9-48 = (P6-04 - P6-03) \times P9-07 \div P5-03 + P6-03$$

Par. No.	Name	Range	Unit	Default
P6-05	Keypad Display Option	0~8191		0

The Keypad is fixed to display the output frequency, reference and motor current (switchable by short press “ENTER” key). This parameter is used to show other physical variable (also install in parameters P9-*), each variable corresponds to a weight. For example, if you want to display the temperature and the terminal AI1 on Keypad. You can set

$$P6-05 = 8 + 128 = 136$$

Below is the list of the weights for all physical variables.

Weight	Parameter Selected	Physical Variable
1	P9-06	Motor Voltage
2	P9-04	Motor Speed
4	P9-11	DC-Voltage
8	P9-13	Temperature
16	P9-20	Feedback Value
32	P9-45	Counter A
64	P9-46	Counter B
128	P9-24	AI1 Input
256	P9-26	AI2 Input
512	P9-35	Pulse Input1
1024	P9-43	Pulse Output1
2048	P9-48	Variable Defined by Customer
4096	P9-05	Output Power

Par. No.	Name	Range	Unit	Default
P6-31	Enabling Local/Remote Mode	0 : Both Enabled 1 : Disable Local Mode 2 : Disable Remote Mode		0

0: Enable Local and Remote Mode, you can press “Loc/Rem” key to switch back and forth between Local and Remote Mode.

1: Disable Local Mode, the drive will mandatory switch to Remote Mode. And the “Loc/Rem”, “RUN”, “STOP” key will be disabled.

2: Disable Remote Mode, the drive will mandatory switch to Local Mode. And the “Loc/Rem”key will be disabled.

Par. No.	Name	Range	Unit	Default
P6-34	Lock Keypad for Parameter Edit	0 : Disabled 1 : Enabled and Lock		0

0: Disabled

1: Enabled and Lock, prevent unauthorized editing of parameters.

Attention: This function is only valid to keypad, not active to local bus.

2.4.8 Parameter Group 7: Auxiliary and Special Functions

Par. No.	Name	Range	Unit	Default
P7-00	Special Operation Function	0 : No Function 9 : Reset Parameters to Factory Defaults		0

0: No function

9: Reset parameters to factory defaults. Reset all the parameters except for information about the drive itself and the parameters recording running history.

Par. No.	Name	Range	Unit	Default
P7-01	Function at Re-Power (for Local Mode Only)	0 : Resume with Set Value as Set before Re-power 1 : Not Run, but Keep Set Value as Set before Re-power 2 : Not Run and Clear Set Value		1

Selects the action upon reconnection of the drive to mains voltage after power down in Hand operation mode.

0: Resume with Set Value as Set before Re-power. Restart with the same local set value and the same start/stop settings as before the drive was powered down.

1: Not Run, but Keep Set Value as Set before Re-power. Keep to the stop status until a new start command is given. The set value set before the drive was powered down is saved and will be used if a new start command is given.

2: Not Run and Clear Set Value. Keep to stop status and clear the set value unit new commands are given.

Par. No.	Name	Range	Unit	Default
*P7-10	Min Switch Frequency	2~16 : 2~16 kHz	kHz	2

Limit the permissible minimal switching frequency also for temperature auto tuning functions

Par. No.	Name	Range	Unit	Default
*P7-11	Over Modulation Coefficient	90.0~105.5	%	100.0

Increase this parameter can increase the ability to output higher voltage with same mains voltage. But increase the ability could result in more harmonic voltage/current on the motor.

Par. No.	Name	Range	Unit	Default
*P7-12	DC-Link Voltage PWM Compensation Function	0 : Compensate Average DC voltage 2 : Compensate DC Ripple Voltage		0

When DC voltage changes, the PWM signals need compensation to apply the right voltage to the motor. This parameter defines how the product compensate the voltage changes.

0 : Compensate Average DC voltage. The product only compensates the changes of the average DC voltage discarding the rectifying ripple voltage.

2 : Compensate DC Ripple Voltage. The product compensates the ripple voltage as well as the average voltage change. This function can reduce the harmonic torque but the effect will be limited if the mains voltage is too low.

Par. No.	Name	Range	Unit	Default
P7-13	DC-link Voltage PWM Compensation Disable at VF control	0 : Disable 1 : Enable		1

This function is used to disable the compensation function at VF control mode. Normally this is used to improve the ramp down capability by dissipating the braking energy in the motor. But doing so is risky to damage the motor in case the mains voltage is high.

Par. No.	Name	Range	Unit	Default
P7-14	Dead Time Compensation Adjustment Coefficient	0~200	%	100

This parameter is used to adjust the dead time compensation due to the tolerance between ideal dead time and real deadtime. 100% means compensate based on ideal dead time, lower than 100% means compensate less than the ideal dead time, higher than 100% means compensate more than the ideal dead time.

Par. No.	Name	Range	Unit	Default
P7-17	Max Frequency for Dead Time Compensation	20~590	Hz	*

From frequency P7-17 and higher, the deadtime compensation coefficient will drop to 0 and the deadtime compensation function is disabled. From 0Hz to P7-17, the deadtime compensation coefficient drops from P7-14 to 0 linearly.

Par. No.	Name	Range	Unit	Default
P7-26	Function at Mains Voltage Sag	0 : No Function 1 : Passive Ramp Down 2 : Passive Ramp Down, Trip 3 : Coast and Fly start 4 : KEB Control 5 : KEB Control, Trip 6 : Trip to stop and Alarm		0

This parameter defines the response when the mains voltage drops to the voltage set in P7-27.

0 : No Function. It's most likely the voltage will trigger the under-voltage limit very soon.

1 : Passive Ramp Down. The product will control the motor frequency following the rotor speed so that no driving torque is applied by the product and the energy consumption is limited as little as possible. Without driving torque, the motor speed will decrease continuously until to 0Hz. If the mains voltage recovers back to above P7-27, the product will ramp the motor back to previous set speed.

2 : Passive Ramp Down, Trip. Similar as [1], the difference is that, if the frequency drops to 0Hz, the product will alarm a fault A.27 and Trip.

3 : Coast and Fly start. The product will disable all the PWM output and coast the motor. When the mains voltage recovers back above P7-27, the product will ramp the motor back to previous set speed with a fly start function.

4 : KEB Control. The product will drive the motor speed down actively so that the kinetic energy of the inertia will be converted back to the DC link.

The DC link voltage will be controlled at the set value. In this way the product can run as long time as possible. In this option, the motor will decrease continuously until to 0Hz if the mains voltage does not recover. If the mains recover back to above P7-27, the product will ramp the motor back to previous set speed.

5 : KEB Control, Trip. Similar as [4]. The difference is that, with option [5] if the frequency drops to 0Hz, the product will alarm a fault A.27 and Trip.

6 : Trip to stop and Alarm. The product will report alarm A.27 and trip to stop.

Note: For option [1] to [5], the drive will report warning "A.36" while doing the selected operation. And if under voltage is triggered, the product will report warning u.24 and further report alarm A.24 and trip if the situation continues for enough time.

Par. No.	Name	Range	Unit	Default
P7-27	Threshold Triggering Mains Voltage Sag Function	100~220/380	V	*

This parameter defines the threshold voltage at which the selected function in P7-26 should be activated.

Note:

- Do not set P7-27 too low or too high. Normally P7-27 should be with 0.7~0.85 of the rated mains voltage. The mains sag function is easy to fail with under voltage triggered if the threshold value is too low. If the threshold value is too high, the product may enter the function all the time.
- If the product is supplied with a DC source, the threshold value will be P7-27 x 1.4.

Par. No.	Name	Range	Unit	Default
P7-28	KEB Control Gain	0 ~ 500	%	100

The control gain for option [4] and [5] of P7-26.

Par. No.	Name	Range	Unit	Default
P7-36	Method to Reset Alarm Fault	0 : Reset by Command 1~10 : Auto Reset for 1~10 Times 11 : Auto Reset for Unlimited Times		0

Define how the alarm faults can be reset.

0: Reset by Command. The alarm faults can on be reset by a command, pressing the "STOP" key, the DI inputs or communication reset command

1~10: Auto reset for 1-10 times. The product can reset 1~10 times of alarm faults automatically after the alarms are triggered.

11: Auto Reset for Unlimited Times. The product will reset the alarm faults without limitation.

Note:

- The product can only reset the alarm fault when the failure reason is cleared. Even if the product fails to reset the alarm fault, it will be counted in times.
- This function works for locked alarm faults only if P5-30=0
- The count of times will be cleared to 0 when the product is re-powered
- This function does not work for warnings.

Par. No.	Name	Range	Unit	Default
P7-37	Alarm Auto Reset Waiting Time	0~600	s	10

Set the time interval from alarm faults to perform the automatic reset function. This parameter is active only when P7-12 set to [1] ~ [10].

Par. No.	Name	Range	Unit	Default
*P7-38	VT Function Level	40~90	%	90

Enter the level of motor magnetization at low speed. Selection of a low value reduces energy loss in the motor, but also reduces load capability, especially for start.

Par. No.	Name	Range	Unit	Default
*P7-39	Min Magnetion at AEO	40~75	%	66

Enter the minimum magnetization must be ensured for AEO. Selection of a low value reduces energy loss in the motor, but can also reduce resistance to sudden load changes and it's easy to stall the motor.

Par. No.	Name	Range	Unit	Default
P7-40	Magnetion Optimization Factor (PM)	-400 ~ 400	%	10

This parameter is used to optimize the balance of copper loss and iron loss in the motor so that to optimize the heat dissipation situation of the motor, but the total efficiency may not be optimized. Adjust P7-40, the motor current can also be changed. This parameter can be used to correct the error of the motor parameters too.

Note: The absolute value of this parameter should not be too high.

Par. No.	Name	Range	Unit	Default
P7-46	Threshold Voltage for OVC Function	Grid Voltage Dependent	V	*

When the DC link voltage exceeds the value of P7-46, over-voltage control defined in P7-47 is activated.

The following table is the Over-voltage Control Threshold Voltage's range and default value depending on P1-01 Grid Type:

Grid Type	Range	Default
200~240V	360~395V	385V
380~440V	680~780V	710V
440~480V	750~780V	780V

Par. No.	Name	Range	Unit	Default
P7-47	OVC Function	0 : Disable 1 : Enable with Mode 1 2 : Enable with Mode 2		0

Over-voltage control (OVC) can limit the voltage in DC link when ramp down the motor by limiting the ramp down speed. It is not suitable for application with continuous potential energy feedback, e.g. lift.

0: Disabled;

1: Mode 1. Control the DC voltage increase by limiting the ramp down speed.

2: Mode 2, usually for very fast deceleration;

Par. No.	Name	Range	Unit	Default
P7-48	OVC Integral Time	0.01~0.10	s	0.05
P7-49	OVC Proportional Gain	0~200	%	100

Define the controller used in OVC control.

Note: These parameters are only active when selecting [2] Mode 1 or [3] Mode 2 in P7-47.

Par. No.	Name	Range	Unit	Default
P7-50	Bypass Speed Start 1	0.0 ~ 590.0	Hz	0.0
P7-51	Bypass Speed End 1	0.0 ~ 590.0	Hz	0.0
P7-52	Bypass Speed Start 2	0.0 ~ 590.0	Hz	0.0
P7-53	Bypass Speed End 2	0.0 ~ 590.0	Hz	0.0
P7-54	Bypass Speed Start 3	0.0 ~ 590.0	Hz	0.0
P7-55	Bypass Speed End 3	0.0 ~ 590.0	Hz	0.0

These parameters are used to define 3 ranges of speed in which the motor should not stay to avoid the mechanical resonance. If the speed is set within the range, the set speed will be move to the closest start point or end point of the bypass speed range.

2.4.9 Parameter Group 8: Basic and Running Information

Par. No.	Name	Range	Unit	Default
P8-00	PU SW Version			

View the software version of the Power Unit.

Par. No.	Name	Range	Unit	Default
P8-01	CU Software Version			

View the software version of the Control Unit.

Par. No.	Name	Range	Unit	Default
P8-30	Total Days with Power On	0~9999	d	

View how many days the drive has been power on. This value can't be reset.

Par. No.	Name	Range	Unit	Default
P8-31	Total Running Hours	0~60000	h	

View how many hours the motor has run. Reset the value to 0 by P8-37 Reset Running Hours Counter.

Par. No.	Name	Range	Unit	Default
P8-32	Total Energy Consumed	0~65535	kWh	

View the total power consumed. Reset the the value to 0 by P8-36 Reset Consumed Energy Counter.

Par. No.	Name	Range	Unit	Default
P8-33	Number of Power Ups	0~65535		

View the number of times the drive has been powered up. This parameter can't be reset.

Par. No.	Name	Range	Unit	Default
P8-34	Number of Over-Temperatures	0~65535		

View the number of that how many over-temperature faults have occurred. This parameter can't be reset.

Par. No.	Name	Range	Unit	Default
P8-35	Number of Over-Voltages	0~65535		

View the number of that how many over-voltage faults have occurred. This parameter can't be reset.

Par. No.	Name	Range	Unit	Default
P8-36	Reset Consumed Energy Counter	0 : Not Reset 1 : Reset		0

0: Not reset;

1: Reset. Reset the counter to zero (see P8-32);

Attention: This parameter can't be set via bus communication.

Par. No.	Name	Range	Unit	Default
P8-37	Reset Running Hours Counter	0: Not Reset 1: Reset		0

0: Not reset;

1: Reset, running hours counter is reset to zero (see P8-31);

Attention: This parameter can't be set via bus communication.

Par. No.	Name	Range	Unit	Default
P8-40~P8-49	Alarm Log			

These are the 10 latest occurred Alarm Log.

Par. No.	Name	Range	Unit	Default
P8-50~P8-59	Warning Log			

This is the 10 latest occurred Warning Log.

2.4.10 Parameter Group 9: Real Time Running Status Monitoring

Par. No.	Name	Range	Unit	Default
P9-00	Control Word	0~65535		
P9-01	Status Word	0~65535		
P9-02	Set Value	-4999.0~4999.0		
P9-04	Motor Speed	0~24000	rpm	
P9-05	Output Power	0.000~655.35	kW	
P9-06	Output Voltage	0.0~6553.5	V	
P9-07	Output Frequency	0.0~590.0	Hz	
P9-08	Output Current	0.00~655.35	A	
P9-09	Output Torque	-200.0~200.0	%	
P9-10	Motor Thermal Load Status	0~100	%	
P9-11	DC Link Voltage	0~65535	V	
P9-13	Heatsink or IGBT Temperature	-128~127	°C	
P9-14	Inverter Thermal Load Status	0~255	%	
P9-15	Nominal Inverter Current	0.0~6553.5	A	
P9-16	Max Inverter Current	0.0~6553.5	A	
P9-17	Power Board Temperature	-128~127	°C	
P9-18	Rectifier Temperature	-128~127	°C	
P9-19	PID Set Value	-200.0~200.0	%	
P9-20	PID Feedback Value	-200.0~200.0	%	
P9-21	PID Output	-200.0~200.0	%	

These parameters are used to view the running status of the product.

Par. No.	Name	Range	Unit	Default
P9-22	Digital Input	0~65535		

View the status of the digital input. Each digital input terminal corresponds to a weight, as shown in the following table. If the drive detects that the digital input terminal is valid, it has a weight, otherwise it does not, and the weight value is added to the parameter value.

For example: F/R and DI2 are valid, P9-22 = 2 + 8 = 10.

Terminal	DI4	DI3	DI2	DI1	F/R	RUN
Weight	32	16	8	4	2	1

Par. No.	Name	Range	Unit	Default
P9-23	AI1 Analogue Input Type	0 : 0~10V 1 : 0~20mA		
P9-24	AI1 Input Value	0.00~20.00	V/mA	
P9-25	AI2 Analogue Input Type	0 : 0~10V 1 : 0~20mA		
P9-26	AI2 Input Value	0.00~20.00	V/mA	

Par. No.	Name	Range	Unit	Default
P9-34	Set Value by Pulse Input	-200.0~200.0	%	
P9-35	Frequency of Pulse Input	0.00~100.00	KHZ	

Par. No.	Name	Range	Unit	Default
P9-37	Speed Feedback from Encoder			

View the Speed Feedback from Encoder in round per second. the motor frequency equals to the value multiplied by the number of motor pole pairs.

Par. No.	Name	Range	Unit	Default
P9-38	DO Output Status	0~255		

View the status of the digital output. Each digital output terminal corresponds to a weight, as shown in the following table. If a digital output terminal is valid, it has a weight, otherwise it does not, and the weight value is added to the parameter value. For example: DO1 is valid, P9-38 = 1.

Terminal	DO1
Weight	1

Par. No.	Name	Range	Unit	Default
P9-39	Relay Output Status	0~65535		

View the status of the relay output. Each relay output terminal corresponds to a weight, as shown in the following table. If a relay output terminal is valid, it has a weight, otherwise it does not, and the weight value is added to the parameter value. For example: Relay1 is valid, P9-39 = 1.

Terminal	Relay 2	Relay 1
Weight	2	1

Par. No.	Name	Range	Unit	Default
P9-40	AO1 output	0.00~20.00	V/mA	

Par. No.	Name	Range	Unit	Default
P9-43	Pulse Output Frequency	0.00~100.00	KHZ	

Par. No.	Name	Range	Unit	Default
P9-45	Counter A Value	0~65535		
P9-46	Counter B Value	0~65535		
P9-47	Set Value from Bus Communication	-32768~32767		
P9-48	Variable Defined by Customer	0~6553.5		

2.5 Application Quick Guide

Normally a Control Unit or a keypad is needed to achieve the applications together with Power Unit. Please refer to 'Chapter 6: Application Quick Guide for SSI800'

2.6 Fault Handling: Warning, Alarm and Error

2.6.1 List of the Faults

SSI800 classify the Faults into 3 categories: Warning, Alarm and Error and they can be shown on the keypad with defined codes.

Warning is for faults close to design limit and parameter set limit, but with which the product can continue to work under a designed control or the product can suspend and recover automatically when the anomaly disappears. Customer can monitor the specific warning information via keypad or communication bus. On an LED keypad, the warning will be shown as 'u.XX'. 'u' means warning, 'XX' represents the code of the fault. On an LCD keypad, the warning information will be shown in normal language.

Alarm is for faults which could damage the product or other equipment in short time so that the product must be disabled from the system immediately. When an alarm is triggered, a 'reset' operation must be taken by a command for keypad or from the upper controller before the product can run again. On an LED keypad, the alarm will be shown as 'A.XX'. 'A' means alarm, 'XX' represents the code of the fault. On an LCD keypad, the alarm information will be shown in normal language. To eliminate some of the faults, customers must power down the product and do debug or test on part of the circuits. For this type of faults, SSI800 afford lock function and when the fault is triggered it will be locked. The locked fault cannot be reset until a power down-power on cycle is operated and the reason for fault is cleared. This type of faults is called locked-fault. All locked-fault will be treated as 'alarm' as well. Customer can disable the lock function for some of the locked-fault by setting P5-30=0. Doing this, the customer must be very careful and be responsible for the safety.

Error is for mis operation from the customer, e.g. trying to change a parameter value via Keypad which is not allowed to change. An Error will be shown as 'Er. XX' on an LED keypad. The product will continue to run and the Error will not be logged.

Below is the list for all the faults.

Warning	Alarm	Error	Fault Name	Reason Description	Suggested Handling
	A.01		Factory Reset	Parameters reset to factory defaults without confirmation	Press "STOP" key to Confirm
	A.02*		Internal Fault		Contact our local support or SSI Company
u.03	A.03*		PU CU communication time out	PU Failed to communicate with CU	1.Power off, then confirm the installation between PU and CU 2.Contact our local support or SSI Company
	A.04*		Power Board 24V Error	Internal Hardware fault	1. Confirm no problem in external load to 24v
	A05*		Gate drive voltage fault	Internal Hardware fault	2. Contact our local support or SSI Company
u.07	A.07*		Fan Fault	Too much dust on the fan or the fan is aged	Clean or replace the fan
u.08			Fan2 Fault	Too much dust on the fan or the fan is aged	Clean or replace the fan
	A.16*		Short Circuit	Short circuit between phases of motor	Check the motor cable and motor insulation status
u.17	A.17*		Earth fault	Flashover or short circuit between output phases and ground	1.Check cable or motor phase to ground insulation status 2.Replace cable or motor
u.19	A.19*		Brake resistor short-circuit	Brake resistor is short circuit (22kW and below)	Check the wire of brake resistor or Replace Brake resistor
u.20	A.20*		Brake transistor short-circuit	Brake transistor is damaged (22kW and below)	Contact our local support or SSI Company to repair
u.21	A.21*		Brake Detect	Brake resistor is not connected or working.	Check the Brake resistor or replace suitable Brake resistor
u.23	A.23		Over Current at low voltage	Over current due to that power supply voltage dips too much	Check the Power supply
u.24	A.24		Under Voltage	Power supply voltage dips too much, or high load to too low power supply voltage	Check the Power supply
u.25	A.25		Overload at low voltage	High load at continuous low power supply voltage	Check the Power supply
u.26	A.26*		Mains Phase Loss	Missing phase on supply side	1.Check the Power supply
u.27	A.27		KEB fault	KEB function triggered but failed to hold the DC voltage at power supply voltage drop, due to too less inertia or two long time for power supply voltage drop.	1.Check the Power supply 2.Set suitable KEB Threshold voltage
	A.28*		Motor phase U missing	1.motor phase imbalance 2.motor cable loose	Check the motor phase cable and motor.

	A.29*		Motor phase V missing		
	A.30*		Motor phase W missing		
u.36	A.36		Over Voltage	1. The input voltage is too high; 2. The motor works in generator mode; 3. The deceleration time is too short; 4. The braking unit and braking resistor are not installed.	1. Check the power supply 2. Use brake resistor or energy feedback unit to consume or use up the generate energy 3. Adjust relative parameters to avoid the motor working in generator mode
u.37	A.37		IGBT Over Temperature	Too high load or the cooling condition beyond the specification	1. Check the load 2. Check the cooling condition, include to clean the airduct or replace the fan
u.38	A.38		IGBT Temperature Sensor Error U		Contact our local support or SSI Company to repair
u.39	A.39		IGBT Temperature Sensor Error V		
u.40	A.40		IGBT Temperature Sensor Error W		
u.41	A.41		Rectifier Temperature High	Too high load or the cooling condition beyond the specification	1. Check the load 2. Check the cooling condition, include to clean the airduct or replace the fan
u.42	A.42		Rectifier Temperature Sensor Error		Contact our local support or SSI Company to repair
u.43	A.43		Power Board Over Temperature	Too high load or too high ambient temperature	1. Check the load 2. Check the cooling condition, include to clean the airduct or replace the fan
u.45	A.45		Over Current	1. Motor parameters and/or motor control parameters are not set appropriately; 2. The power size of inverter is too small comparing to the motor or the load 3. The power supply voltage is too low; 4. The inverter failed to catch a spinning motor at fly	1. Adjust relevant parameters 2. Select inverter with higher power rating 3. Check the power supply voltage 4. Contact our local support or SSI Company
u.46	A.46		Drive Overload	1. Too heavy load or too low power supply voltage 2. The power size of inverter is too small comparing to the motor or the load 3. Motor parameters and/or motor control parameters are not set appropriately;	1. Correctly set relevant parameters especially the motor parameters 2. Select inverter with high power rating. 3. Contact the local distributor or SSI Company
u.48	A.48		Motor Over Temperature	1. Too heavy load on the motor 2. Cooling condition for the motor is not good enough 3. Thermistor for motor temperature sensing is not used correctly	1. Check selection/installation of the thermistor for motor temperature sensing 2. Check the cooling conditions for motor 3. Check the load versus rated power of the motor
u.49	A.49		Motor Overload	1. Motor parameters and/or motor control parameters are not set appropriately; 2. Too heavy load on the motor	1. Correctly set relevant parameters especially the motor parameters 3. Check the load versus rated power of the motor
u.50	A.50		Current Limit	Current exceeds the parameter set max. current (P5-07) due to: 1. Too heavy load comparing to the power size of the inverter 2. Too fast ramp with inertia 3. Too low power supply voltage 4. Motor parameters and/or motor control parameters are not set appropriately;	Adjust P5-07 or try A.45 solution
u.51	A.51		Torque Limit	Torque exceeds the parameter set max. torque (P5-04/P5-05).	Adjust P5-04/P5-05 or try A.45 solution
u.57	A.57		Analogue input terminals Error	1. Wire connection problem 2. The parameters for AI1/AI2 live zero are not correctly set	1. Check the wire connection 2. Adjust the relevant parameter setup

u.62	A.62		Communication Timeout	Drive communication timeout (with external controller PC/PLC/HMI etc.) 1. External controller abnormal 2. communication line connection problem 3. communication Parameters(P0-8X) incorrect. 4.EMC problem.	1.Check external controller PC, PLC, HMI etc. 2.Check communication line connection 3.Correctly set communication parameters(P0-8X) 4. Wiring the communication cables correctly, including shielding and grounding 5.Contact our local support or SSI Company
u.66			Motor Loss	Motor cable connection or motor problems;	Check motor cable or motor phase
	A.69		Mechanic Brake Current Low	Actual motor current cannot exceed release brake current (P1-97~P1-98) within start delay time.	Correctly set mechanical brake parameters(P1-97~P1-98)
u.75			Drive License Timeout	Drive License Timeout function activated	Contact our local support or SSI Company
u.76	A.76		External alarm	DI terminals select external alarm function	Check external alarm source
		Er.90	CU communication Timeout	CU Failed to communicate with PU	1.Power off, then confirm the installation between PU and CU 2.Contact our local support or SSI Company
		Er.91	KEY disabled	The KEY disabled	Please refer parameter P6-31
		Er.93	Parameter change disabled	The parameter cannot be changed when Drive running	Change the parameter after Drive stop
		Er.95	Keypad communication Timeout	Keypad failed to communicate with PU or CU	1. Check the connection between Keypad and PU/CU 2. Make sure PU or CU works properly
	A.99		AMA Error	Failed to finish the motor parameter auto tuning	Correctly set motor parameters according to motor nameplate

Note: The Alarms marked with '**' are locked-faults.

2.6.2 How to Get the Fault Info

For Power Unit PU00, the customer must get the fault information by connecting a keypad or installing a Control Unit with keypad (e.g. CU00), or get the fault information via the RS485 on the Control Unit. However, PU01 can support more in addition to what PU00 does. AS shown below, PU01 affords a RS485 port which can be used for fault information as well as control. PU01 also has two LED lights to show the status of product.

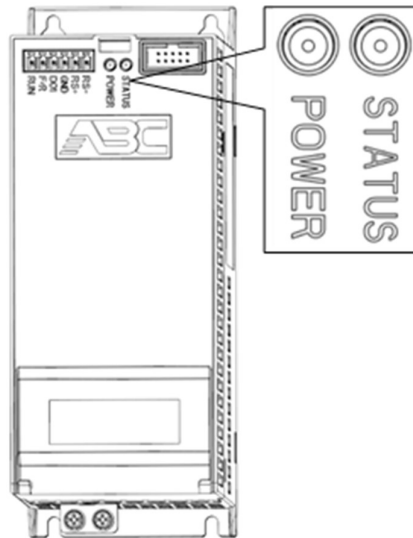

The meaning of the PU01 LED lights is described as below:

LED Name	Color	Reponses	Meaning
POWER	Green	Always On	Powered and power supply ok
		Always Off	Not power, or problem in power supply
STATUS	RED	Always Off	Product is OK
		Flashing	Warning with Fault
		Always On	Alarm with Fault

2.7 Maintenance

The parts of product could be impacted by the environment temperature, humidity, vibration, salt mist, dust etc. Proper maintenance of the product during storage and running is important to keep the product from failure and life reduction.

2.7.1 Routine Inspection

Below items should be suggested for routine inspection :

- Any abnormal sound from the motor during running?
- Any abnormal vibration from the motor during running?
- Is there any special change in the installation environment?
- Are the cooling fans running ok?
- Check the temperatures inside the product via the parameter group 9
- Check the motor voltage, current and frequency
- Is there any special dust, e.g. metal dust or corrosive liquid?

2.7.2 Maintenance

According to the application, customer can check the product at a regular interval, e.g. every 3~6 months to clear the hidden problem.

Items for Maintenance	Measures
Control terminals loose?	Fasten the screws with a torque-controlled screw driver if loose
Power terminals loose	Fasten the screws with a torque-controlled screw driver or socket wrench if loose
PE terminals loose?	Fasten the screws with a torque-controlled screw driver or socket wrench if loose
Fixation of the product loose?	Fasten the screws with a torque-controlled screw driver or socket wrench if loose
Control wire or power cable worn?	Replace the wire or cable
Air duct blocked?	Clean the air duct
Fan speed too low or blocked?	Clean or replace the fan

Caution:

Please power off the product and wait for enough time to ensure safety before maintenance;
 Avoid dropping any screws, wire lead and other metal materials inside the product, otherwise it could be damaged when power on;
 It is forbidden to do any change inside the product.

2.7.3 The storage and transportation of product

The product should be stored inside the package before installation. Below items are demanded for storage:

- In a dust free and dry environment;
- Storage temperature: -25°C~65°C ;
- Storage humidity: 5%-95% and no condensing;
- Storage in environment without corrosive gas or liquid;
- Put on shelf away from the ground with package;
- Transportation ambient temperature: -25°C~70°C;
- Transportation ambient humidity: below 95%

Caution: It's inadvisable to store the product for long time due to electrolytic capacitors inside. If you DO need to store the product for long time please follow below rules:

- Power the product every 6 months for more than 5 hours in a special way
- Power the product before the first time running in a special way
- The special way to power the product means to power the product with a voltage and current controlled supply and increase the voltage slowly, normally with a voltage regulator.
- Power the product directly to high voltage after long time storage could explode the electrolytic capacitors.

2.7.4 Scrapping of the product

Materials used in the product are recyclable to save resource and protect the environment. For example, the package material is biodegradable and recyclable. All the metal parts can be recycled as well as the plastic and rubber. Scrapping the Printed Circuit Board and electrolytic capacitor should follow standards IEC62635. All the handling for scrapping of the product should follow the local regulations.

Chapter 3 Operation Instruction for SSI800 Control Unit CU00

3.1 Mechanic and Electric Installation

3.1.1 Outline Dimensions

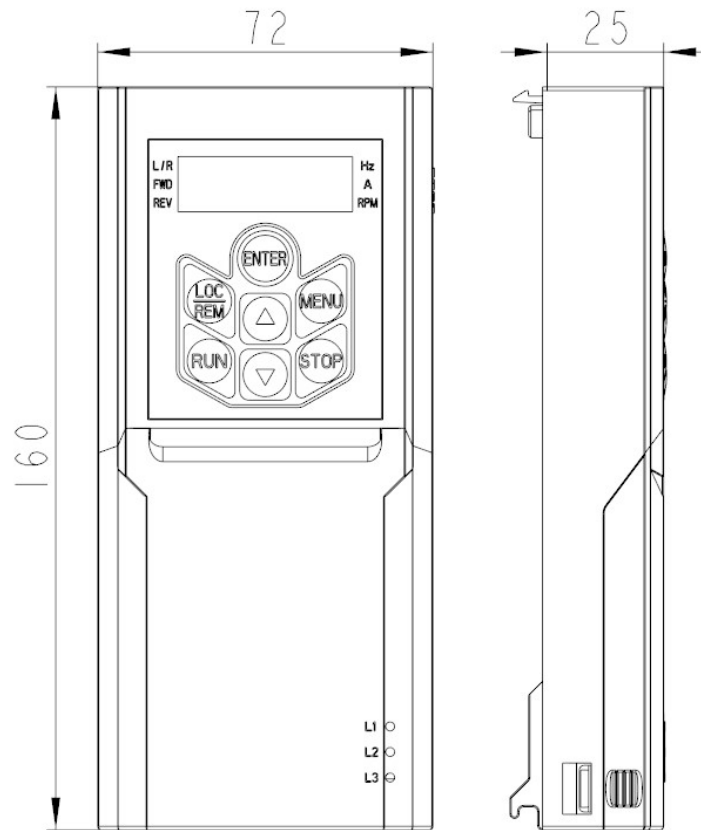

Install to and Dismount from the Power Unit

Please refer to 1.6.2.

3.1.2 Electrical Diagram

The electrical diagram of CU00 is shown as below.

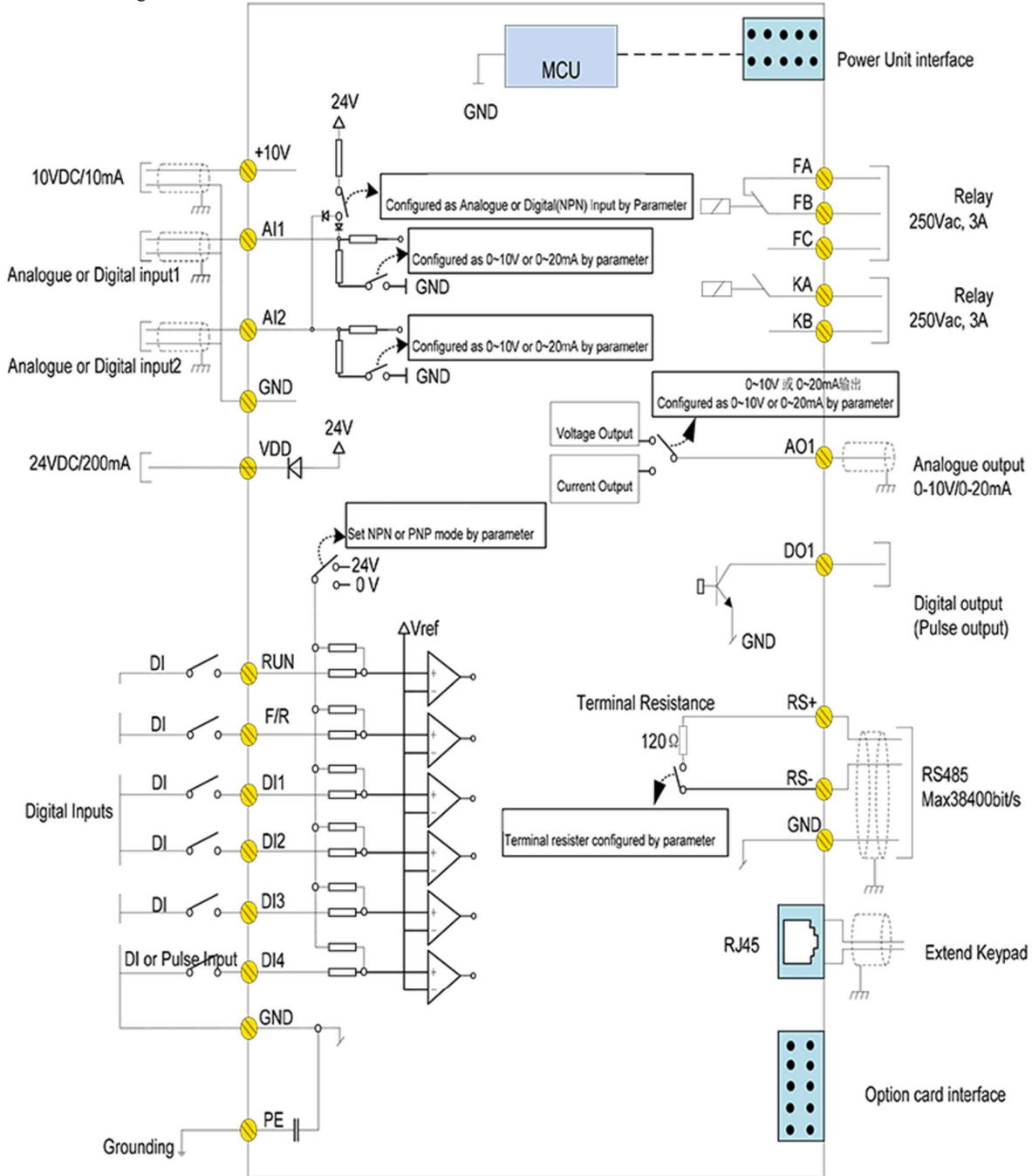

3.1.3 Terminals

3.1.3.1 Specification of the terminals:

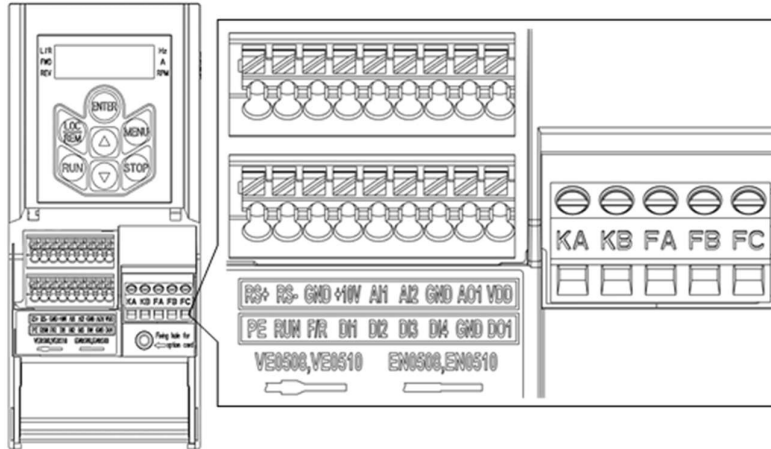

Specification of the terminals:

Name	Function	Specification
RUN, F/R, DI1, DI2, DI3, DI4	Digital inputs	Input type: NPN PNP Input Voltage: 0~30V; Input Impedance: 3.6kΩ; DI4 can be configured as pulse input
DI4	Pulse Input	Frequency Range: 0.00~100.00kHz; Power Supply Range: 24V ± 20%; Duty Cycle Range: 40%~60%;
DO1	Digital Output	Output type: Open Collector; Output Current: 0~40mA; Output Voltage: 0~30V; Can be configured as pulse output: Load Capacity: Resistive >1kΩ, capacitive <10nf; Frequency Range: 0.00~100.00kHz; Duty Cycle Range: 40%~60%;
RS+, RS-	RS485 Communication	Max Baud Rate: 38400bit/s; Configurable termination resistor, open in default
FA-FB-FC KA-KB	Relay Output	Resistive Load: 250VAC 3A/30VDC 3A ; Inductive Load: 250VAC 0.2A/24VDC 0.1A (cosφ=0.4) ;
AI1, AI2	Analogue Inputs	Configurable as analogue voltage inputs, analogue current inputs as well as digital inputs. 1. As Analogue Voltage Inputs: Input Impedance: 10kΩ; Input Voltage Range: 0~10V; 2. As Analogue Current Inputs: Input Impedance: ≤500Ω; Input Current Range: 0~20mA; 3. As Digital Inputs: a) Input Type: NPN PNP b) Input Impedance: 10kΩ; c) Input Voltage Range: 0-30V
AO1	Analogue Output	Configurable as analogue voltage output or current output Output Range: 0~10V or 0~20mA; Load Capacity: As Voltage Output: Impedance > 500Ω; As Current Output: Impedance < 500Ω;
VDD	24V Power Supply	Max 200mA
+10V	10V signal power supply	Max 10mA
GND	Signal Ground	
PE	Safety Ground	
Other Connectors:		
Connector for Option Card		Support one option card of different types, at the bottom of the Control Unit
Connect for External Keypad		RJ45 for external keypad, at the top of right side of the Control Unit

3.1.3.2 Guidance for Connecting Wires

Except for the relay outputs, Spring-Clip terminals are used for all the control signals. Tope type terminal is recommended for the control wires with specification as below:

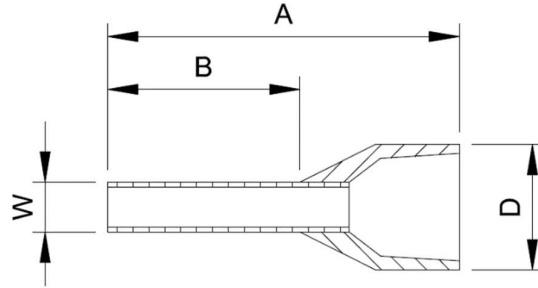

A	B	D(max)	W
14	8	3.5	1.4

Units : mm

Wir diameter specification :

Type	Minimal Diameter	Maximal Diameter
Single Conductor	0.52mm ²	0.82 mm ²
Multi-folded Wire	0.52mm ²	0.82 mm ²
Connector Lug	0.52mm ²	0.52mm ²

Push the wire tupe into the terminal directly and the wire will be clamped automatically by the terminal spring;

To remove the wire, use a slot type screwdriver to push down the lock on the terminal then the wire will be released. The specification for the head of the screwdriver: Thickness 0.4mm, width 2.5mm;

Ideal length for the wire stripping is 9mm.

Screw fasten terminals are used for relay output:

Please select the right screwdriver to fasten the terminals. If a slot type screwdriver is used, below specification is recommended: head width 3.5mm, head thickness 0.6mm;

Ideal length fir wire stripping is 6~7mm;

Diameter specification for wires:0.4~1.0mm² , Torque specification for fastening the terminal: 0.4 N·m ;

3.1.3.3 Electrical connection for Digital Inputs

SSI800 Control Unit CU00 supports both NPN and PNP inputs.

For NPN inputs, below connection is recommended:

数字量输入NPN型接线方式
Wiring for NPN DI

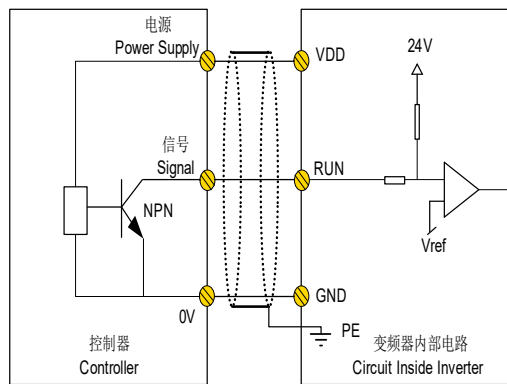

For PNP inputs, below connection is recommended:

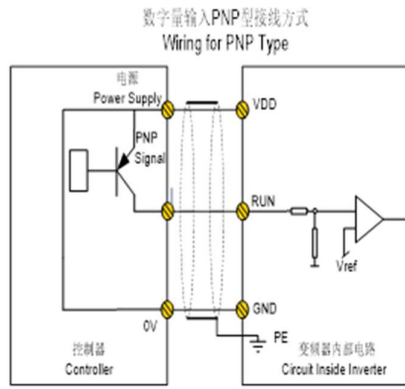

3.1.3.4 Electrical connection for Digital Outputs

Below connection is recommended to use Digital output to drive relay:

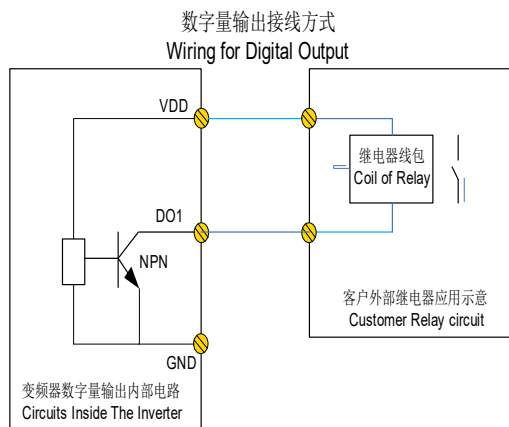

3.2 Keypad Operation Guidance

The keypad built in CU00 can be used for parameter set/read, control and monitoring etc. Below shows the appearance of the keypad.

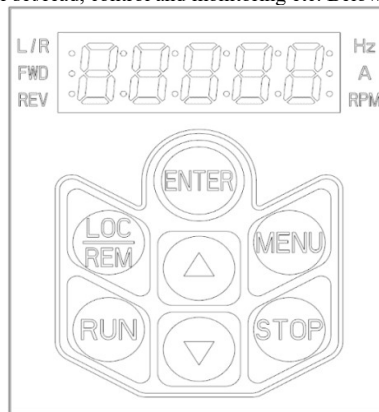

Customer can switch the product between two different running modes with the keypad key: Local Mode and Remote Mode.

Local Mode: The product is controlled by keypad, including start/stop and target set etc.

Remote Mode: The product is controlled by I/O terminals or communication Bus, keypad is only for monitoring and parameter setup.

Description of the lights on keypad

L/R Light: To indicate the mode of the product, Always On --- Remote Mode, Flashing --- Local Mode.

FWD、REV Lights:

FWD	REV	Status
On	Off	Running in Forward Direction
Off	On	Running in Reverse Direction
Off	Off	Stopped

Hz、A Lights: To indicate the physical meaning and units of the data displayed, please refer to 3.2.2.

Display

Total 5 Digits of LED to show the set value, output frequency and running data, warnings and alarms etc.

Keypad Keys

Key Name	Function
LOC/REM	Switch the product between Remote Mode and Local Mode per press (The product is default in Remote Mode).
RUN	Press to start the motor, only works in Local Mode.
STOP	Short Press to stop the motor, Long Press to reset the fault (if there is alarm) each time if “STOP” is pressed, the product will be forced into Local Mode.
	Press to increase the numerical value of parameter or parameter number
	Press to decrease the numerical value of parameter or parameter number
MENU	Press to enter the menu for parameter setup or exit the menu
ENTER	Short Press: in home display, Short Press to switch the physical variables shown; in parameter number selection, Short Press to switch the digit place of the parameter number to be modified; in parameter value modification, Short Press to switch the digit place of parameter value to be modified Long Press: Long Press to confirm the parameter number selection and enter the parameter value displaying/modification, or Long Press to confirm the parameter value and back to the Parameter number selection menu.

3.2.1 How to Set Parameter

Take change the parameter P1-06 rated motor current to 9.6A as an example:

From home display, press the “MENU” key to enter the parameter number selection.

Short Press the “ENTER” key to select the digit place of parameter number you want to change and Press “▲” or “▼” key to adjust the parameter number to “P1-06”

Long Press the “ENTER” key to confirm the parameter number selection and enter the the parameter value

Short Press the “ENTER” key to select the digit place of parameter value you want to change and Press “▲” or “▼” key to adjust the parameter value to “9.6”

Long Press the “ENTER” key to confirm the parameter value input and back to the parameter number selection, parameter number “P1-07” will be shown.

Repeat the operation steps 2 to 5 if more parameters need to be changed. Press the “MENU” key back to the home display

Notes:

Long Press the “▲” or “▼” key can speed up the change of numeric value;

In parameter number selection or parameter value modification, if no operation for certain period, the keypad will jump back to the home display automatically

3.2.2 Monitor the Product Status

In the default setup, the keypad will only show one of the motor frequencies, set value and motor current in home display (switchable by “ENTER” key). If more physical variables need to be shown in the home display, you can set the parameter P6-05. You can use the “ENTER” key to switch and select one of the variables defined in P6-05 and show it in the home display.

Blow table shows the meaning and how them will be shown for the main physical variables which can be defined in P6-05.

Physical Variable	Monitoring Parameter	Indication Character	LED lights Status
Output Frequency	P9-07	T	“Hz” Always On
Set Value	P9-02	N/A	“Hz” Always On “A” Always ON
Motor Current	P9-08	A	“A” Always On
Motor Voltage	P9-06	N/A	“Hz” Always On “RPM” Always On
Motor Speed	P9-04	N/A	“RPM” Always On
DC Voltage	P9-11	N/A	“A” Always On “RPM” Always On
Inverter Temperature	P9-13	N/A	“RPM” Flashing
Feedback Value	P9-20	N/A	“Hz” Always On “RPM” Flashing
Analogue Inputs	P9-24 或P9-26	N/A	“Hz” Flashing “RPM” Flashing

3.2.3 Check the Fault Log (Warning or Alarm Log)

The keypad will show the fault code when any fault is triggered. The product can log 10 latest warnings and 10 latest alarms. You can check the latest warning information via parameters P8-40~P8-49 and alarms via parameters P8-50~P8-59.

3.2.4 Comparison Table for Character Displaying

0	1	2	3	4	5	6	7	8	9
0	1	2	3	4	5	6	7	8	9
A	B	C	D	E	F	G	H	I	J
A	B	C	D	E	F	G	H	I	J
K	L	M	N	O	P	Q	R	S	T
	L		n	o	p	q	r	s	t
U	V	W	X	Y	Z	-	+	.	=
U	U			y	z	-	+	.	=
a	b	c	d	e	f	g	h	i	j
A	B	C	D	E	F	G	H	I	J
k	l	m	n	o	p	q	r	s	t
	L		n	o	p	q	r	s	t
u	v	w	x	y	z				
U	U			y	z				

3.3 CU00 Application Quick Guide and Notes

CU00 needs to work together with Power Unit to achieve the main applications, please refer to “Chapter 6 SSI800 Basic Application Guide”.

Notes:

When the CU00 is powered on, the CPUD will scan whether an option card is installed first. If yes, then external keypad cannot work, if not, an external keypad can be connected and works at any time.

If both an option card and an external keypad are installed at power on, the product may not work properly.

NEVER install or remove an option card when the product is powered on, but you can connect and disconnect an external keypad even the product is powered on.

Chapter 4 Instruction for other Options of SSI800

4.1 External Keypad AD-KP01

Keypad AD-KP01 is not released yet, but its functions and specifications are quite similar as the built-in keypad of CU00. Detailed information will be available when the final release of AD-KP01

AD-KP01 can be connected to Control Unit CU00 via the RJ45 connector with standard internet cable (refer to 1.6.3), it can also be connected to CU01 via standard internet cable or installed on CU01 directly. AD-KP01 it can also be connected to Power Units (PU00/PU01) via the 10 PIN connector with standard IDC 2.54mm 10Pin flat cable (refer to 1.6.1.1). Customer can buy the cable from us or from a third party. Comparing with the built-in keypad of CU00, AD-KP01 will have an incremental digital potential meter.

4.2 External Keypad AD-KP02

AD-KP02 is not released. Comparing with AD-KP01, AD-KP02 will use LCD screen and it can show 7 lines of text, as well as picture's, Wi-Fi and Real Time Clock function will be added too. The way to connect AD-KP02 is compatible as AD-KP01 except for AD-KP02 is much bigger. More information will be available when released.

4.3 Option Cards AD-PG01/AD-PG02/AD-PG03

SSI800 Control Units support different types of PG cards, please refer to 1.3.2. More information will be available after released.

4.4 Option Cards AD-DP1/AD-PN1

SSI800 Control Units support AD-DP01 for Profibus-DP and AD-PN1 for Profinite (Please refer to 1.3.2). More information will be available after released.

Chapter 5 Operation Instruction for SSI800 Combination Type

By installing a Control Unit to a Power Unit, different combination types of product can be achieved to fulfil different application demands. Here only the standard type (combination of PU00 and CU00) is described, other combination type will follow similar logic.

Description of the Type Code:

Model: SSI800-4T7D5H/011L-PU00CU00		
1-5	SSI800	From SSI800 family
6-7	4T	Line in votage, 4T: 3 phase 400V, 2T: 3 phase 200V, 2S: Single phase 200V
8-15	7D5H/011L	Rated Power, 7D5: 7.5kw, H: Heavy Load Type, 011: 11kw, L: Light Load Type. For Models not supporting dual rating, digits 12~15 will be null
16-19	PU00	The type of Power Unit
20-23	CU00	The Type of Control Unit

Note : (“/” and “-” are not counted in the number of digits)

5.2 Specification and Function for Combination Type

A combination type will have all the functions and follow all the specifications of the modules used including Power Unit and Control Unit, except for functions listed as below:

- The DI/DO/RS485 on the Power Unit will not be available anymore. Only control terminals and communication ports on Control Unit will work.
- The LED lights on Power Unit for status monitoring will be invisible (covered by Control Unit)
- The 10 Pin IDC connector on Powered Unit is occupied by connection to Control Unit, Keypad can only be connected to the Control Unit.

5.3 Safety Instruction for Combination Type

Safety demands for a combination type should follow the safety demands of the Power Unit which is installed into the combination type (refer to 2.1)

Note: Do NOT plug or remove the Control Unit from the Power Unit when the product is powered on.

5.4 Installation and Wiring for Combination Type

Except for 25mm increase in the depth, installation of a combination type should follow the demands as for the Power Unit (refer to 2.2)

5.5 Operation for Combination Type

Keypad Operation of a combination type follows the Control Unit or Keypad built into the combination type.

Except for the customer defined parameters, all the parameters are the same as parameters of the Power Unit built into the combination type.

5.6 Maintenance

Please refer to 2.7.

Chapter 6 SSI800 Basic Application Guide

Power Unit should be combined with a Control Unit or keypad together to achieve most of the applications described here.

6.1 Control with Keypad

Ensure the product is working in Local Mode (L/R light flashing), or press the “LOC/REM” key to switch to Local Mode.

Adjust the set frequency by pressing the “▲” or “▼” key.

Press the “RUN” key to start the motor, and adjust the motor speed by pressing the “▲” or “▼” key.

Press the “STOP” key to stop the motor.

Note: In Local Mode, the product only receives commands from the keypad. Normally Local Mode is for system debugging.

6.2 Control with Terminals

First ensure the product is working in Remote Mode (L/R light always ON). If not, switch the product to the Remote Mode by press the “LOC/REM” key. The product is default in Remote Mode.

Control in default parameter setup: In default, the DI terminal named as “RUN” is set to function of start/stop (P2-05=10), the DI terminal named as “F/R” is set to function of selecting motor direction (P2-06=11), and the main set value source is set to AI1 terminal (P0-11 = 1), and the AI1 terminal is set as analogue voltage input (P3-00=0). In the default parameter setup, you can start the motor by enabling the signal to terminal “RUN” (short circuit the “RUN” terminal to “GND”) and stop the motor by disconnecting the terminal “RUN” from terminal “GND”. You can control the motor direction to reverse by enabling the signal to terminal “F/R” and direction to forward by disconnecting the terminal “F/R” from the terminal “GND”. You can change the motor speed by adjusting the voltage on terminal AI1.

Control with pulse input: Based on the default parameter setup, you only need to change the main set value source to pulse input (P-011 = 5), and set the function of terminal “DI4” to pulse input. Then you can start/stop the motor via terminal “RUN”, control the motor direction via terminal “F/R” and control the motor speed by changing the frequency of the pulse applied to terminal “DI4”.

Control with Preset multi-stage value: Based on the default parameter setup, you need to change the main set value source to preset multi-stage value (P0-11=11) and keep the function of terminals “DI1”~“DI4” as default (P2-07~P2-10 = 22~25), and set the preset values in parameters P0-30~P0-45 to the speeds you expect. Then you can start/stop the motor via terminal “RUN”, control the motor direction via terminal “F/R”, and change the motor speed to preset value by changing the logic status of terminals “DI1” ~ “DI4”.

6.3 Reset the parameters to Factory Defaults

Set parameter P7-00 = 9;

Power down the product fully and power on again, the keypad shows A.01

Press the “STOP” key to clear the A.01, then the parameters are reset to factory defaults except for the parameter group 8 and group 9.

6.4 Reset the Faults (Alarms)

For non-locked faults, press “STOP” key to reset the fault.

For locked faults:

If parameter P5-30 = 0, press “STOP” to reset the fault;

If parameter P5-30 =1, you need to power down and power on first, then press “STOP” key to reset the fault.

You can also set a DI terminal function to reset fault (set one of the parameters from P2-05 to P2-10 equals 1), and use DI signal to reset the fault.

6.5 Motor Parameters Auto Tuning

Correct motor parameters help to ensure the control performance. Motor parameter auto tuning function can identify the motor parameters (parameters from P1-14 to P1-27) automatically. If you did not run the motor parameter auto tuning operation, the control will use default motor parameters or use the parameters you set manually.

Ensure the motor is standstill

Set Parameters from P1-02 to P1-07 as the nameplate of the motor

Set parameter P1-13 to value 1 or 2 or 3 or 4 or 5 depending on your demands (Refer to description of parameter P1-13 in 2.4)

After you confirm the parameter P1-13 value, the keypad will show “PUSH” “RUN”. Then press the “RUN” key, the product starts the motor parameter auto tuning function

Wait the until the keypad shows “PUSH” “Ent”, then press the “ENTER” key. The motor parameter auto tuning function finished and the motor parameters are updated.

Note: You can stop the motor parameter auto tuning function by press the “STOP” key.

Appendix A. Modbus Communication Guidance

The SSI800 drive provide RS485 communication interface. It adopts international standard Modbus communication protocol to perform master-slave communication. The user can realize centralized control through PC/PLC to adapt specific application requirements.

1. Application Mode

1.1 Interface Mode

The communication interface is RS485. RS485 works on semi duplex and its data signal applies differential transmission which is called balance transmission too.

1.2 Networking Mode

The drive has two networking modes: single master/multiple slaves networking and single master/single slave networking.

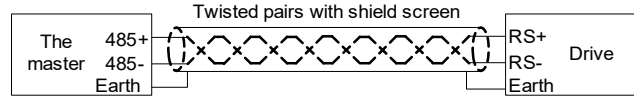

Single master/single slave networking diagram

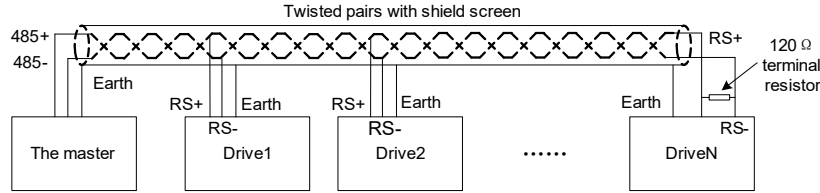

Single master/multiple slaves networking diagram

Specification:

1. No matter which mode, the drive is used as a slave in communication. When master sends commands using broadcast address, the slave does not respond;
2. It is recommended to use shield cables in multiple connection. The basic parameter of the devices, such as baud rate and digital check bit in RS485 should be the same as slave device's and there should be no repeated addresses in slave devices.

2. Protocol Format

Modbus protocol only support RTU mode.

RTU data frame format is shown as the figure below:

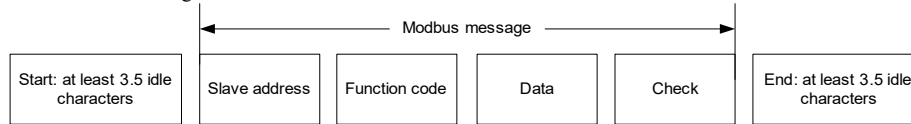

Specification:

Start	At least 3.5 idle characters
Slave address	Address : 0-127(0 is broadcast address)
Function code	Modbus function code
Data (N-1)	2 * N data
Data (N-2)	
...	
Data 0	
CRC CHK high-8-bit	CRC check
CRC CHK low-8-bit	
End	at least 3.5 idle characters

3. Function Code

Function code supported by SSI800 drive Modbus protocol are as shown in the table below:

Function code	Description	Meaning
0x03	Read Holding Registers	Read drive functional parameters and running status parameters
0x06	Preset Single Register	Over-write individual drive functional parameters
0x10	Preset Multiple Regs	Over-write multiple Registers

4. Register Address Definition

All the following register addresses are started from 0.

4.1 The Rules of Register Address of the Parameter Number

The parameters can be mapping to register address. The rules of register address of the parameter number are shown below:

$$\text{Register address} = \text{PNU} - 1$$

For example:

The register address of P0-30 is $30 - 1 = 29$ (0x001D)

The register address of P9-11 is $911 - 1 = 910$ (0x038E)

Attention:

Parameters Group 8 and 9 are Read-only.

The Drive don't support write or read multiple parameters at a time.

4.2 Other Register Addresses Specification

In addition to parameter is mapped to Modbus registers, there are some additional registers within the drive which can be used to control the drive, monitor the drive's status. These registers can support write or read maximum 10 registers at a time.

Register address	Specification	R/W
------------------	---------------	-----

9999*	Control command	W
10000*	Frequency command	W
10099*	State	R
10100*	Warning/Alarm code	R
10101	Output frequency (0~Fmax, unit: 0.1Hz)	R
10102	Output current (unit: 0.01A)	R
10103	Output voltage (unit: 1V)	R
10104	Output power (unit: 0.01kW)	R
10105	Motor speed (unit: 1rpm)	R
10106	DC bus voltage (unit: 1V)	R
10107	Reference	R
10108	Process PID Feedback	R

* Reg. 9999 specification

Bit	Specification
Bit 7~0(run/stop control etc.)	0x00: No function 0x01: Run forward 0x02: Reverse 0x03: Jog 0x04: Jog reverse 0x05: Stop 0x06: Coast 0x07: Reset
Bit 11~8(Preset value select)	0000B:P0-30(Preset Value 0) 0001B: P0-31(Preset Value1) ... 1111B: P0-45(Preset Value 15)
Bit 13~12(Ramp time select)	00B: Ramp 1 01B: Ramp 2 10B: Ramp 3 11B: Ramp 4
Bit 14	Reserved
Bit 15	1B: Enable Bit8~13 function 0B: Disable Bit8~13 function

* Reg. 10000 specification

When using communication to control the drive, you can set the frequency directly by writing register 10000 . The register value is in the range of 0.00 ~ P5-08, unit 0.01Hz.

* Reg. 10099 specification

* Reg. 10099 specification

Bit	Specification
Bit 0	0B: None 1B: Warning
Bit 1	0B: None 1B: Alarm
Bit 3~2	00B: Stop 01B: Run forward 10B: Reverse 11B: Reserved
Bit 7~4	Reserved
Bit 11~8	0000B: Using Preset Value 0 0001B: Using Preset Value 1 ... 1111B: Using Preset Value 15
Bit 15~12	Reserved

* Reg. 10100specification

Register 10100 is used to read the drive warning/alarm code. For example: When the drive occurs A.48 alarm, the value of register 10100 is 48. When the drive occurs u.24 warning, the value of register 10100 is 24.

5. Communication ratio values

The Communication data is expressed by hexadecimal in actual application and there is no radix point in hexadecimal. For example, if you want to set P5-08 = 61.5, 61.5 can be magnified by 10 times into 615. So hex 0x0267 (615) can be used to express 61.5.

A non-integer can be timed by a multiple to get an integer and the integer can be called communication ratio values.

The communication ratio values are referred to the radix point of the setting range of default value in the functional parameter list. If there are radix point n, then the communication ratio value m is 10ⁿ.

6. Error message

There may be errors in the communication process, for example, some parameters are read-only, but the PC/PLC sends a written directive, the drive will return an error message.

Error message data frame format is shown as the figure below:

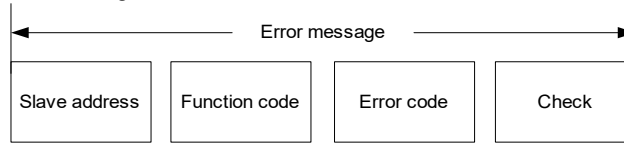

Error message function code = requirements function code + 0x80

Error code	Specification
0x01	Function code error, the drive does not support this kind of function code.
0x02	The register address is invalid.
0x03	The value exceeds the upper limit of the parameter
0x04	Operation error.

7. Examples

7.1 Read Holding Registers (0x03)

7.1.1 Read Motor speed

Read parameter P9-04(Reg 903) to get the Motor speed.

Transmit: 01 03 03 87 00 01 34 67 (Hexadecimal)

Receive: 01 03 02 05 DC BA 8D (Hexadecimal)

Transmit data specification:

Field	Description
01	Address
03	Function
03 87	Register address: 903(0x0387)
00 01	The number of read registers is 1

Receive data specification:

Field	Description
01	Address
03	Function
02	The byte number of received data
05 DC	0x05DC converts to decimal number is 1500. So, the value of P9-04 is 1500RPM

7.1.2 Read Drive Status, warning/alarm code and output frequency

Read multiple Registers 10099、10100、10101 to get all information.

Transmit: 01 03 27 73 00 03 FE A4 (Hexadecimal)

Receive: 01 03 06 00 04 00 00 01 F4 D0 A2 (Hexadecimal)

Transmit data specification:

Field	Description
01	Address
03	Function
2773	Register address: 10099(0x2773)
00 03	The number of read registers is 3
FE A4	CRC check

Receive data specification:

Field	Description
01	Address
03	Function
06	The byte number of received data
00 04 00 00 01 F4	The value of Reg. 10099 is 0x0004. Note: Bit 0 is 0B, that is No warning; Bit 1 is 0B, that is No Alarm; Bit 3~2 is 01B, that is Run forward; Bit 11~8 is 0000B, that is Using Preset Value 0; The value of Reg. 10100 is 0x0000(0). The drive doesn't have warning/ alarm, so it is 0. The value of Reg. 10101 is 0x01F4(500). So, the drive output frequency is 500/10=50.0Hz.

7.2 Write Single Register (0x06)

Set motor rated speed to 1430RPM.

Write P1-07(Reg 106) =1430.

Transmit: 01 06 00 6A 05 96 2A E8 (Hexadecimal)

Receive: 01 06 00 6A 05 96 2A E8 (Hexadecimal)

Transmit data specification:

Field	Description
01	Address
06	Function
00 6A	Register address of P1-07 is :107-1= 106(0x006A)
05 96	The value wants to set to P1-07 is 0x0596(1430)

Receive data specification:

Field	Description
01	Address
06	Function
00 6A	Register address of P1-07 is :107-1= 106(0x006A)
05 96	The value of P1-07 is 0x0596(1430)

7.3 Write Multiple Registers (0x10)

Start the drive and set Drive output frequency.

Write register 9999 to control the drive running and write register 10000 to set the drive output frequency.

Transmit: 01 10 27 0F 00 02 04 00 01 09 C4 5A 1D (Hexadecimal)

Receive: 01 10 27 0F 00 02 7B 7F (Hexadecimal)

Transmit data specification:

Field	Description
01	Address
10	Function
27 0F	Register address: 9999(0x270F)
00 02	The number of write registers is 2
04	The byte number of write data is 4
00 01 09 C4	Reg. 9999= 0x0001 Note: Bit 7~0 is 0x01, that is Run forward; Bit 11~8 is 0000B, that is Using Preset Value 0; Bit 13~12 is 00B, that is Using ramp 1; Bit 15 is 0B, that is Disable bit 13~8; Reg. 10000= 0x09C4(2500, So the Reference frequency is 2500 / 100 = 25.00Hz)

Receive data specification:

Field	Description
01	Address
10	Function
27 0F	Register address: 9999(0x270F)
00 02	The number of write registers is 2
01	Address

1. Summary

The SSInverter inverter is equipped with a variety of expansion cards as optional accessories. In order to cover more application industries and provide more IO functions, IO expansion cards are now provided to expand digital and analog functions.

IO01	Digital input: 3, Support PNP&NPN mode Digital output: 2, OC open output ; Analog input: 2, -10V~+10V: 0~10V/0~20mA ; Resister input 1, 0~400ohm ; Analog output: 2, 0~10V output ; 0~20mA output ; Supply output : +10V ; Max current 10mA ;
------	--

Notice :

- Confirm that the CU model of the SSI inverter to be installed supports the expansion card function; (you can note when ordering or consult SSI company)
- CU00 cannot support both the external keypad and the expansion card at the same time. ;
- When installing or removing an expansion card, please ensure that the machine is powered off; hot swapping is prohibited. Otherwise, the machine or expansion card may be damaged. ;

2. IO01 card installation instructions

Installation steps : Check the expansion card accessory package contains: PG card, pluggable terminal *1, screw *1, manual ; Install the expansion card as shown below :

Step 1. Push the expansion card along the bottom rail into the bottom of the CU. The terminals of the expansion card are inserted into the bottom of the CU terminal, and the two screw holes are aligned.

Step 2, as the picture shows, align the screws with the screw holes to fix the CU and the expansion card;

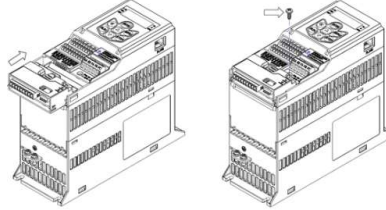

3. Electrical instructions

3.1 IO01 Card

3.1.1 IO01 Diagram

3.1.2 IO01 terminals and specifications

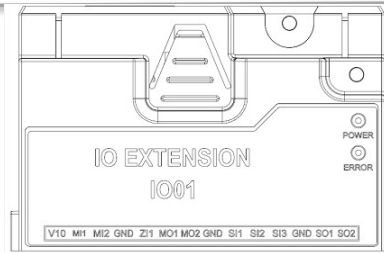

Terminal	Function	Specification
SI1/SI2/SI3	Digital input signal	Input type : select NPN and PNP mode by parameters; NPN Mode/PNP Mode; Input Voltage : 0~30V ; Input resistance : 3.6KΩ ;
SO1/SO2	Digital output signal	OC Output ; Output current range : 0~40mA ; Output voltage range : 0~30V ;
MI1	Analog input signal	Analog voltage input port: Input voltage range : -10V~+10V ; External input signal -10V~10V converter to 0~10V, Read this value from P9-28. (Eg. Set P3-25=-100% to get reverse reference, then 5V=0% ref, 10V=100% ref,-10V=-100% ref) Input resistance : 10KΩ;
MI2		Voltage input and current input can be selected by parameters : 1. As analog voltage input: Input voltage range: 0 ~ 10V; The input impedance is 10KΩ; 2. As analog current input: Input current range: 0 ~ 20mA; The input impedance is about 500Ω;
ZI1	Resistance signal input	Resistance signal input port: Input resistance range: 0 ~ 400Ω; Accuracy: 12bit;
MO1	Analog output signal	Current signal output: Output current range: 0 ~ 20mA; When the current is output, the load impedance is less than 500Ω;
MO2		Voltage signal output: Output voltage range: 0 ~ 10V; When the voltage is output, the load impedance is greater than 500Ω;
V10	10V power supply	10V+/- 0.1V Max 10mA output;
GND	Internal power ground	



Status light	Description	Status light
ERROR	Fault status indicator	Red light is always on: fault of communication between option card and CU Red light is off: normal or not powered
POWER	Power Indicator	The green light is always on: Power indication is normal The green light is off: the power is off or the power is abnormal.

4. IO expansion card parameter description

Para-meter	Name	Setting range	Unit	Factory default
P2-11	Expansion card SI1 input	0: Invalid; 1: Reset 2: Free running stop (antilogical) 3: Reset free running stop(antilogical) 4: Stop(antilogical); 10: Start 11: Running direction selection 12: Reverse start: 13: Pulse start 14: Pulse reversal: 15: Jog forward 16: Jog reversal 20: No turning forward 21: No reversal 22: Multiple command terminal 1 23: Multiple command terminal 2 24: Multiple command terminal 3 25: Multiple command terminal 4 26: Acceleration and deceleration terminal 1 27: Acceleration and deceleration terminal 2 30: UP 31: DOWN 32: Counter A 34: Reset counter A 35: Counter B 37: Reset counter B 40: Pulse input 41: Set value source switch 42: Speed control/torque control switch 50: External fault input 51: PID pause		0

P2-12	Expansion card SI2 input			0
P2-13	Expansion card SI3 input			0
Para-meter	Name	Setting range	Unit	Factory default
P2-23	Expansion card SO1 output	0: Invalid; 1: Ready 2: Remote control ready 3: Ready-not running 4: Running; 5: Running—No warning; 6: Run within current range: no warning; 7: Run at the set frequency: no warning 8: Reverse operation; 10: Fault; 11: Warning or fault; 12: Overheat warning; 13: Ready-no overheat warning; 14: Remote control ready-no overheat warning; 15: Communication is normal 16: Communication control word Bit1; 17: Communication control word Bit12; 20: Out of current range; 21: Below current limit 22: Above current limit 23: Out of frequency range 24: Below frequency limit 25: Above frequency limit 26: Out of feedback range 27: Below feedback limit 28: Above feedback limit 29: Out of the set value range 30: Below the set value limit 31: Above the set value limit 40: Local operating status 41: Remote operating status 42: Mechanical brake 43: External fault; 44: Eccentric fault		0
Para-meter	Name	Setting range	Unit	Factory default
P2-24	Expansion card SO2 output			0
P3-18	Expansion card MI1 input type	0 : Voltage signal 1 : Current signal		0
P3-19	Expansion card MI1 filter time	0.00~10.00	S	0.01
P3-20	Expansion card MI1 zero dead zone	0.00~20.00	V/m A	0
P3-21	Expansion card MI1 minimum voltage	0.00~P3-22	V	0
P3-22	Expansion card MI1 maximum voltage	P3-21~10.00	V	10
P3-23	Expansion card MI1 minimum current	0.00~ P3-24	mA	0
P3-24	Expansion card MI1 maximum current	P3-23~20.00	mA	20
P3-25	Expansion card MI1 minimum reference/feedback value	200.00~200.00	%	0
P3-26	Expansion card MI1 maximum reference/feedback value	200.00~200.00	%	100
P3-27	Expansion card MI2 input type	0 : Voltage signal 1 : Current signal		0
P3-28	Expansion card MI2 filter time	0.00~10.00	S	0.01
P3-29	Expansion card MI2 zero dead zone	0.00~20.00	V/m A	0
P3-30	Expansion card MI2 minimum voltage	0.00~P3-22	V	0
P3-31	Expansion card MI2 maximum voltage	P3-21~10.00	V	10
P3-32	Expansion card MI2 minimum current	0.00~ P3-24	mA	0
P3-33	Expansion card MI2 maximum current	P3-23~20.00	mA	20
P3-34	Expansion card MI2 minimum reference/feedback value	-200.00~200.00	%	0

P3-35	Expansion card MI2 maximum reference/feedback value	-200.00~200.00	%	100
P3-36	Expansion card ZI type			
Para-meter	Name	Setting range	Unit	Factory default
P3-37	Expansion card ZI maximum value			
P3-38	Expansion card ZI minimum value			
P3-56	Expansion card MO1 output type	0 : 0~20mA 1 : 4~20mA		0
P3-57	Expansion card MO1 output function selection	0: Invalid 1: Output frequency 2: Motor current 3: Output power 4: Motor speed 5: Output voltage 10: Set value 11: Feedback value 13: Bus control 14: Pulse input 15: AI1 input value 16: AI2 input value 20: DC bus voltage 30: Output torque		0
P3-58	Expansion card MO1 minimum output ratio	0.00~200.00	%	0
P3-59	Expansion card MO1 maximum output ratio	0.00~200.00	%	100
P3-60	Expansion card MO1 minimum output	0.00~P3-61		0/4.00
P3-61	Expansion card MO1 maximum output	P3-60 ~ 10.00 / 20.00		10/20.00
P3-62	Expansion card MO2 output type	3 : 0~10V		0
P3-63	Expansion card MO2 output function selection	0 : Invalid 1 : Output frequency 2 : Motor current 3 : Output power 4 : Motor speed 5 : Output voltage 10 : Set value		0
Para-meter	Name	Setting range	Unit	Factory default
P3-63	Expansion card MO2 output function selection	11 : Feedback value 13 : Bus control 14 : Pulse input 15 : AI1 input value 16 : AI2 input value 20 : DC bus voltage 30 : Output torque		0
P3-64	Expansion card MO2 minimum output ratio	0.00~200.00	%	0
P3-65	Expansion card MO2 maximum output ratio	0.00~200.00	%	100
P3-66	Expansion card MO2 minimum output	0.00~P3-61		0/4.00
P3-67	Expansion card MO2 maximum output	P3-60~10.00/20.00		10/20.00
P9-27	Expansion card MI1 signal type	0 : 电压信号 1 : 电流信号		
P9-28	Expansion card MI1 input value	0.00-20.00	V/m A	
P9-29	Expansion card MI2 signal type	0 : 电压信号 1 : 电流信号		
P9-30	Expansion card MI2 input value	0.00-20.00	V/m A	
P9-31	Expansion card ZI1 input value			
P9-41	Expansion card MO1 output value	0.00~20.00	V/m A	
P9-42	Expansion card MO2 output value	0.00~20.00	V/m A	

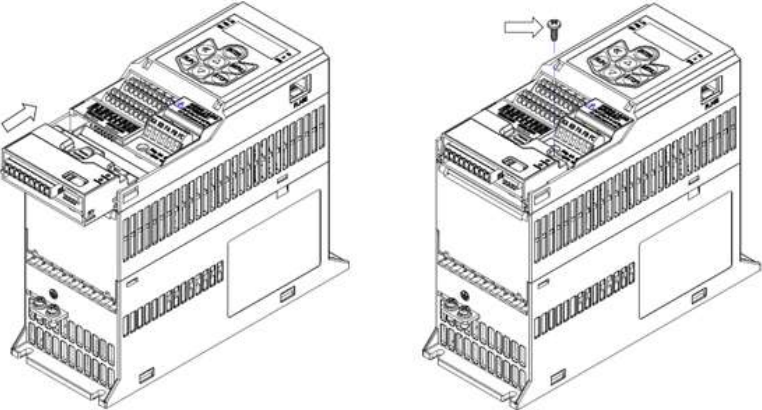
PG		
<p>SSI inverter is equipped with a variety of encoder expansion cards (ie PG cards) as optional accessories, which is a must for the inverter to realize speed closed-loop vector control. Please select the corresponding PG card according to different encoder output. The specific models and selection are as follows. Please select the corresponding SSI PG card model according to the selected encoder. The models are as follows:</p>		
PG01	<p>Power supply : 12V/24V; 150mA ; Input : A/B/Z signal ; Voltage type / OC / push-pull incremental signal, Max.50kHz Frequency division output : A1 B1 (Frequency division adjustable, range : 1~255)</p>	
PG02	<p>Power supply : 5V, 200mA ; Input : A+/A-,B+/B-,Z+/Z- Differential incremental signal, Max.200kHz Frequency division output : A+/A-;B+/B- (Frequency division adjustable, range : 1~255)</p>	
PG03	<p>Source: REF+/REF-,7VRMS, 10KHZ/20KHZ Port: SIN+/SIN-,COS+/COS-; Frequency division output : AO+/AO-,BO+/BO-;ZO+/ZO- (Frequency division adjustable, range : 1)</p>	
<p>Notice :</p> <ul style="list-style-type: none"> ● Confirm that the CU model of the SSI inverter to be installed supports the expansion card function; (you can note when ordering or consult SSInverter company) ● CU00 cannot support both the external keypad and the expansion card at the same time. ; ● When installing or removing an expansion card, please ensure that the machine is powered off; hot swapping is prohibited. Otherwise, the machine or expansion card may be damaged. ; 		
2. PG card installation instructions		
<p>Installation steps : Check the expansion card accessory package contains: PG card, pluggable terminal *1, screw *1, manual ; Install the expansion card as shown below :</p> <ul style="list-style-type: none"> ● Step 1. Push the expansion card along the bottom rail into the bottom of the CU. The terminals of the expansion card are inserted into the bottom of the CU terminal, and the two screw holes are aligned. ● Step 2, as the picture shows, align the screws with the screw holes to fix the CU and the expansion card; 		
		
3. Electrical instructions		

3.1 PG01-Common Encoder

3.1.1 PG01 Wiring Diagram

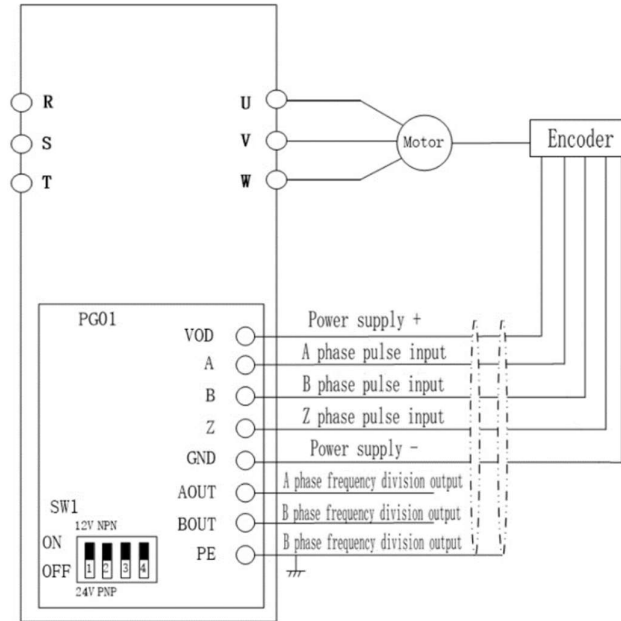

3.1.2 PG01 terminals and specifications

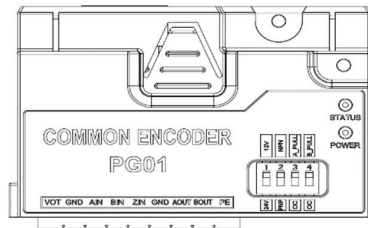

Terminal name	Function	Specification
AIN/BIN/ZIN	Pulse input signal	Maximum input signal 50KHZ ; Acceptable encoder input model : Push-pull output type ; Voltage output type ; Open collector output type ;
AO/BO	Frequency division output signal	The frequency division output coefficient is set by software parameters, frequency division range is 1-255.
VOT	Encoder power supply	Select 12V or 24V through the DIP switch, the default is 24V ; Power output accuracy : 24V(12V) +/-10%; Maximum output current 150mA ;
GND	Internal power ground	
PE	Safety Ground	
DIP switch SW1	SW-1 Power selection switch	OFF:24V default ON:12V
	SW-2 Encoder mode selector switch	OFF: (Push-pull type、 Voltage type) default ON: (Push-pull type、 Open collector type)
	SW-3 Frequency division output A phase pull-up selection	OFF: No pull-up, open collector output default ON: Pull up to VOD
	SW-4 Frequency division output B phase pull-up selection	OFF: No pull-up, open collector output default ON: Pull up to VOD
Status light	Description	Status light
STATUS	Fault status indicator	STATUS
POWER	Power Indicator	POWER

3.2 PG02 Differential PG card

3.2.1 Wiring diagram

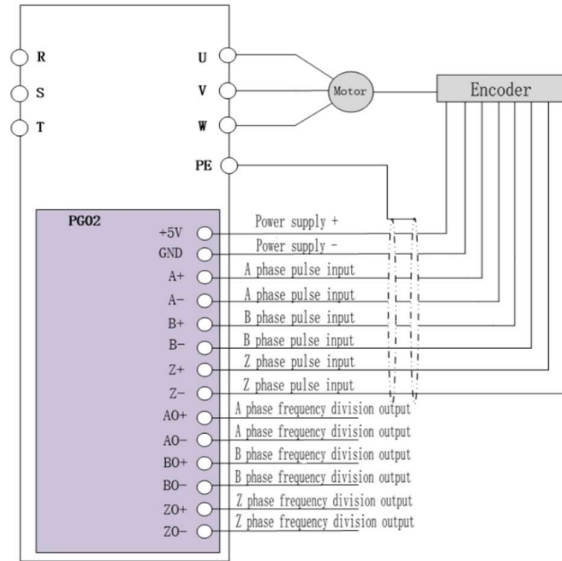

3.2.2 端子排布及规格说明

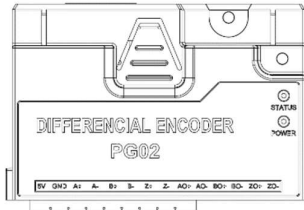

Terminal name	Function	Specification
A+/A-/B+/B-/Z+/Z-	Pulse input signal	Maximum input signal 50KHZ ; Acceptable encoder input model : Differential incremental encoder input ;
AO+/AO-/BO+/BO- /ZO+/ZO-	Frequency division output signal	The frequency division output coefficient is set by software parameters, frequency division range is 1-255.
5V	Encoder power supply	5V power output ; +/- 4%; Power supply accuracy : 5V+/- 4%; Maximum output current 150mA ;
GND	Internal power ground	
PE	Safety Ground	
Status light	Name	Description
STATUS	Fault status indicator	Red light is always on: fault Red light is off: normal or not powered
POWER	Power Indicator	The green light is always on: Power indication is normal The green light is off: the power is off or the power is abnormal.

3.3 PG03 Resolver Option

3.3.1 PG03 Wiring Diagram

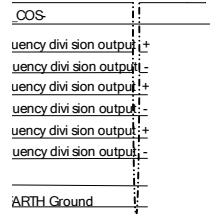

3.3.2 Terminals and specifications

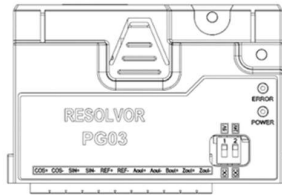

Terminal name	Function	Specification		
A+/-A-/B+/B- /Z+/Z-	Pulse input signal	Maximum input signal 50KHZ ; Acceptable encoder input model : Differential incremental encoder input ;		
AO+/-AO- /BO+/BO- /ZO+/ZO-	Frequency division output signal	The frequency division output coefficient is set by software parameters, frequency division range is 1-255.		
5V	Encoder power supply	5V power output ; +/- 4%; Power supply accuracy : 5V+/- 4%; Maximum output current 150mA ;		
GND	Internal power ground			
PE	Safety Ground			
Status light	Name	Descriptions		
STATUS	Fault status indicator	Red light is always on: fault Red light is off: normal or not powered		
POWER	Power Indicator	The green light is always on: Power indication is normal The green light is off: the power is off or the power is abnormal.		
Parameter number	Name	Setting range	Unit	Factory default
P2-70	Encoder resolution	0~4096		1024
P2-71	Encoder rotation direction	0 : Clockwise * 1 : Counterclockwise		0
P2-74	Resolver Source frequency	0 : 10 * 1: 10.87 2: 11.63 3: 12.82 4: 13.89 5: 15.63 6: 17.24 7: 20	KHZ	0
P5-19	Motor speed feedback interrupt response function	0 : invalid 3 : Jog running 4 : Speed limit running 5 : Malfunction and tripping stop 11 : Open loop running		5
P5-20	Motor speed feedback interrupt detection threshold	1 ~ 600	rpm	300
P5-21	Motor speed feedback interrupt detection time	0.00 ~ 60.00	s	0.05
P9-37	Encoder feedback			

PG04 WIFI Cards

SSInverter inverter is equipped with a variety of encoder expansion cards (PG cards) as optional accessories, which is a necessary option for speed closed-loop vector control. PG04 provides a resolver type encoder for use.
And provide WIFI function for networking, remote monitoring, remote control and other functions.

PG04 WIFI

Resolution ratio : 12bit
Excitation source : REF+/REF-:7VRMS; 10KHZ ;
Input : SIN+/SIN-;COS+/COS-;
Frequency division output : A1 B1 (Frequency division adjustable, range : 1~255)

WIFI

- Networking function: 2.4GWIFI can be used to connect to the Ethernet router to realize the networking function;
- Cloud platform function: the system can be remotely monitored on the WEB end to facilitate unified management in the background;
- APP function: the system can be directly monitored through the mobile phone APP, supporting remote control, technical Parameters:
 - Wireless standard: 802.11b/g/n
 - Transmission speed: up to 54Mbps
 - Frequency range: 2.400GHZ~2.484GHZ

Notice :

- Confirm that the CU model of the SSI inverter to be installed supports the expansion card function; (you can note when ordering or consult SSI company)
- CU00 cannot support both the external keypad and the expansion card at the same time. ;
- When installing or removing an expansion card, please ensure that the machine is powered off; hot swapping is prohibited. Otherwise, the machine or expansion card may be damaged. ;

2. PG04 WIFI installation instructions

Installation steps : Check the expansion card accessory package contains: PG card, pluggable terminal *1, screw *1, manual ; Install the expansion card as shown below :

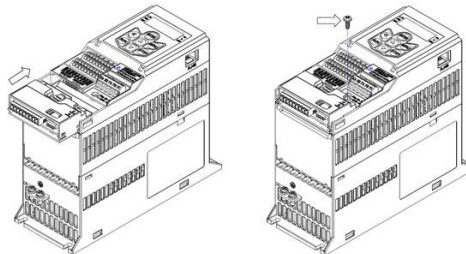

Step 1. Push the expansion card along the bottom rail into the bottom of the CU. The terminals of the expansion card are inserted into the bottom of the CU terminal, and the two screw holes are aligned.

Step 2, as the picture shows, align the screws with the screw holes to fix the CU and the expansion card;

3. Electrical instructions

3.1 PG04 WIFI Diagram

3.2 PG04 WIFI Terminals and specifications

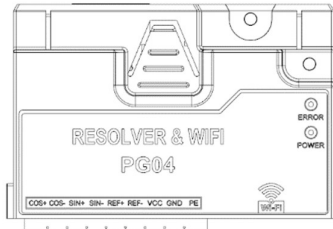

Terminal name	Function	Specification
REF+/ REF-	Excitation source	Excitation frequency : 10KHZ Excitation output voltage : 7VRMS
SIN+	Feedback sine signal positive	Feedback sine signal positive
SIN-	Feedback sine signal negative	Feedback sine signal negative
COS+	Feedback cosine signal positive	Feedback cosine signal positive
COS-	Feedback cosine signal negative	Feedback cosine signal negative
5V	The output power	5V+/- 2%; 150mA
GND	Power ground	
PE	Safety Ground	

Status light	Description	Status light
STATUS	Fault status indicator	Red light is always on: fault Red light is off: normal or not powered
POWER	Power Indicator	The green light is always on: Power indication is normal The green light is off: the power is off or the power is abnormal.

4. Parameters

Parameter number	Name	Setting range	Unit	Factory default
P2-70	Encoder resolution	0~4096		1024
P2-71	Encoder rotation direction	0 : Clockwise 1 : Counterclockwise		0
P5-19	Motor speed feedback interrupt response function	0 : invalid 3 : Jog running 4 : Speed limit running 5: Malfunction and tripping stop 11 : Open loop running		5
P5-20	Motor speed feedback interrupt detection threshold	1 ~ 600	rpm	300
P5-21	Motor speed feedback interrupt detection time	0.00 ~ 60.00	s	0.05

Note: When using resolver, P2-70 must be set to 1

5. WIFI Functions

5.1 Connection settings

The WIFI expansion card works in AP mode, the network name is: SSI_DRIVER_WIFI, and the link password is 12345678. Between the WIFI expansion card and the inverter directly use the UART communication interface, with a baud rate of 115200, 1 stop bit, 8 data bits, and no parity. The TCP protocol is used for communication between the client and the WIFI expansion card. The WIFI expansion card is TCP SERVER, the address is 192.168.4.1, and the port number is 8086. The user accesses as a TCP Client, and only one Client can access at a time.

5.2 Brief introduction of WIFI communication protocol

The Modbus communication protocol format is followed between Client and WIFI expansion card. Currently supports 0x03, 0x06, 0x08 and 0x10 commands. Among them, 0x03, 0x06 and 0x10 are general Modbus commands. For the test of general Modbus command frame, please refer to the Modbus protocol chapter of SSI manual. Command 0x08 is a special command used to modify the SSID and password of the network.

5.3 Examples of communication commands

5.3.1 Example of reading holding register 03h

Read motor speed

You can check the motor speed by reading parameter p9-04 (register 903).

Sending of data: 01 03 03 87 00 01 34 67 (hexadecimal)

Receiving of data: 01 03 02 05 dc ba 8d (hexadecimal)

Sending of data

Field	Description
01	Inverter address
03	Function code
03 87	Register address 903 (0x0387)
00 01	The number of registers to be read is 1

Receiving of data

Field	Description
01	Inverter address
03	Function code
02	Number of bytes of received data
05 DC	0x05DC is converted to a decimal number as 1500. Parameter P9-04 has no decimal places, so the motor speed is 1500.

Read inverter status, fault code and output frequency

The above information can be obtained by continuously reading three registers 10099, 10100, and 10101.

Sending of data: 01 03 27 73 00 03 FE A4 (hexadecimal)

Receiving of data: 01 03 06 00 04 00 00 01 F4 D0 A2 (hexadecimal)

Sending of data

Field	Description
01	Inverter address
03	Function code
2773	Register address 10099 (0x2773)
00 03	The number of registers to be read is 3
FE A4	CRC Check code

Receiving data

Field	Description
01	Inverter address
03	Function code
06	Number of bytes of received data
00 04 00 00 01 F4	The value of register 10099 is 0x0004, Note: Bit 0 value: 0B, that is, no warning Bit 1 value: 0B, that is, no fault Bits 3~2 value: 01B, that is forward running Bits 11~8 value: 0000B, that is, the multi-speed selection is the preset setting value 0. The value of register 10100 is 0x0000. At this time, the inverter has no fault and warning, so the fault and warning code is 0 The value of register 10101 is 0x01F4, which is 500, and register 10101 has a decimal point, so the output frequency is 50.0Hz

5.3.2 Example of writing a single holding register 06H

Set the motor rated speed to 1430RPM

Set parameter P1-07=1430

Send data: 01 06 00 6A 05 96 2A E8 (hexadecimal)

Receive data: 01 06 00 6A 05 96 2A E8 (hexadecimal)

Sending of data

Field	Description
01	Inverter address
06	Function code
00 6A	Register address, the register address of parameter P1-07 is 107-1=106 (0x006A)
05 96	The value to be written into the parameter P1-07 is 1430 (decimal 1430, hexadecimal 0x0596)

Receiving of data

Field	Description		
01	Inverter address		
06	Function code		
00 6A	Register address, the register address of parameter P1-07 is 107-1=106 (0x006A)		
05 96	The value written in parameter P1-07 is 1430 (decimal 1430, hexadecimal 0x0596)		
5.3.3 Example of writing multiple holding registers 10H Start the inverter and set the inverter operating frequency. The running status of the inverter can be controlled by register 9999, and the running frequency of the inverter can be set by register 10000. Send data: 01 10 27 0F 00 02 04 00 01 09 C4 5A 1D (hexadecimal) Receive data: 01 10 27 0F 00 02 7B 7F (hexadecimal) Sending of data			
Field	Description		
01	Inverter address		
10	Function code		
27 0F	Register address 9999 (0x270F)		
00 02	Number of registers to be written		
04	Number of bytes to be written		
00 01 09 C4	Register 9999= 0x0001 Note: Bits 7~0 value: 0x01, namely forward running Bits 11~8 value: 0000, namely the preset value 0 Bits 13~12 value: 00B, namely acceleration and deceleration 1 Bit 15 value: 0, that is, bits 13~8 are invalid Register 10000 = 0x09C4 Note: 0x09C4 is converted to a decimal number as 2500, and the precision of register 10000 is 0.01Hz, so set the operating frequency to 25.00Hz		
Receiving of data			
Field	Description		
01	Inverter address		
10	Function code		
27 0F	Register address 9999 (0x270F)		
00 02	Number of registers to be written		
5.3.4 Example of changing network name and password 08H Set the network SSID to ABC123 Send data: 01 08 00 01 41 42 43 31 32 33 30 E2 If it is wrong, it will return an error frame: 01 + 88 + Err Type + CRC If the configuration is correct, the TCP Client is disconnected, you need to reconnect to the network with a new password, reconnect to the Client, and no return frame is returned. Sending of data			
Field	Description		
01	Inverter address		
08	Function code: specially used to modify the SSID and password of the network		
00	Modification type: 00 means change SSID, 01 means change password		
	Data length: (password length can only be 8)		
	Data: Data is the ASCII code of characters		
	CRC Check code		
ASCII code correspondence table :			
Character	ASCLL-Hexadecimal	Character	ASCLL- Hexadecimal
0	30	6	36
1	31	7	37
2	32	8	38
3	33	A	41
4	34	B	42
5	35	C	43
Receiving of data			
Field	Description		
01	Inverter address		
88	Function code		
	Err Type: 0x01 illegal function code 0x02 illegal data address 0x04 CRC check error 0x09 PU communication failure 0x0A exceeds the maximum number of parameters 0x0B illegal parameter 0x0C illegal type 0x0D Illegal password length		
	CRC Check code		
5.3.5 Password setting of WIFI Set the password as: 01234567;			

The format of the sending command frame is: 01 08 01 08 30 31 32 33 34 35 36 37 EE 2D;
 If it is wrong, it will return an error frame: 01 + 88 + Err Type + CRC;
 If the configuration is correct, the TCP Client is disconnected, you need to reconnect to the network with a new password, reconnect to the Client, and no return frame is returned.

Register address	Description	Read/write
9999(0x270F)	control commands 0x00: No command 0x01: Forward running 0x02: Reverse running 0x03: Forward jog 0x04: Reverse jog 0x05: Decelerate to stop 0x06: Free stop 0x07: Fault reset	Write
10000 (0x2710)	Operating frequency, accuracy 0.1HZ	Write
10099 (0x2773)	Inverter status, equivalent to parameter 9.01	Read
10100 (0x2774)	Inverter fault code, equivalent to parameter 8.40	Read
10101 (0x2775)	Output frequency, unit 0.1Hz, equivalent to parameter 9.07	Read
10102 (0x2776)	Output current, equivalent to parameter 9.08	Read
10103 (0x2777)	Output voltage, equivalent to parameter 9.06	Read
10104 (0x2778)	Output power, equivalent to parameter 9.05	Read
10105 (0x2779)	Motor speed, equivalent to parameter 9.04	Read
10106 (0x277A)	DC bus voltage, equal to parameter 9.11	Read

Restore network defaults

If the customer forgets the set network name and password, please send the following command to restore:

Send command: 01 08 02 00 81 7A

If it is wrong, it will return an error frame: 01 + 88 + Err Type + CRC

If the configuration is correct, the TCP Client is disconnected, you need to reconnect to the network with a new password, reconnect to the Client, and no return frame is returned.

Note:

- When the WIFI is disconnected, the inverter will automatically stop. Therefore, in order to maintain the WIFI connection, it is recommended to read and write any register value periodically.
- When sending a control command frame to the WIFI expansion card, you must wait until the return frame of the previous frame of data is received before sending the next frame of data.

PROFINET

The SSInverter PN01 card is a PROFINET fieldbus adapter card, which conforms to the international PROFINET Ethernet. The modified card is installed on the AD800 series inverter to improve the communication efficiency and facilitate the realization of the inverter networking function, so that the inverter becomes the slave station of the field bus and accepts the control of the field bus master. SSI PN01 is suitable for AD800 series full power range (0.37kW~415kW), and it may support more series products in the future.

Before using this product, please read this guide carefully.

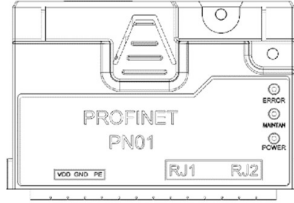

Features:

- The bus communication rate reaches 100Mbit/s, the communication cycle is short, and it supports IO and RT;
- Flexible networking topology, SSI PN01 supports all types of topologies: chain, bus, tree or star, etc.
- The expansion card is directly installed on the expansion card slot, no external power supply is required, and the installation is convenient.

2. PROFINET Installation

Installation steps :

1. Check the expansion card accessory package contains: Profinet card, pluggable terminal *1, screw *1, manual ;
2. Install the expansion card as shown below :

Step 1. Push the expansion card along the bottom rail into the bottom of the CU. Then terminals of the expansion card are inserted into the bottom of the CU terminal, and the two screw holes are aligned;

Step 2, as the picture shows, align the screws with the screw holes to fix the CU and the Profinet card.

Note: When installing the Profinet, should be make sure that the DP01 card and the CU interface pin are inserted in place and the pin is not bent, otherwise the communication may not work or not stable.

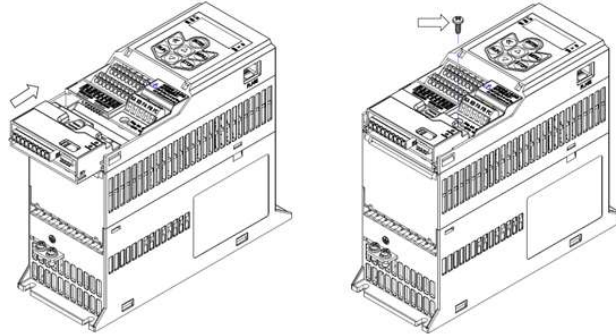

3. Electrical connections

The SSI PN01 module uses a standard Ethernet RJ45 socket to connect to the PROFINET master station, and its pin signal definition is the same as the standard Ethernet pin, cross-wire and straight-wire are both available.

1) Chain network electrical connection

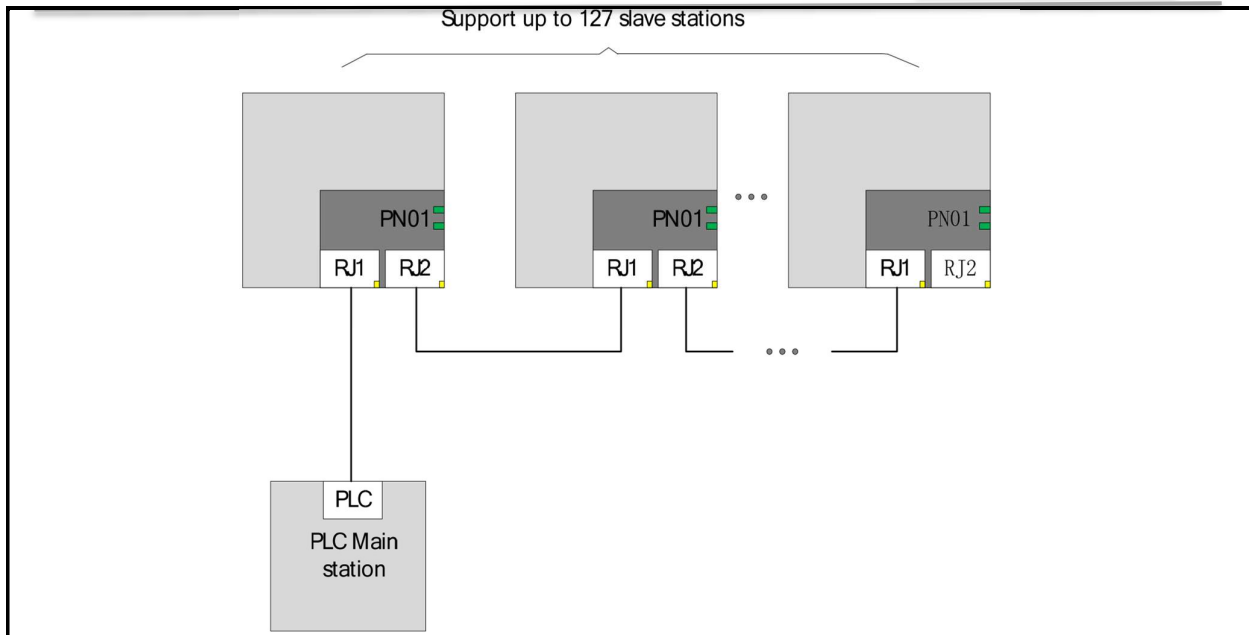

2) Star network electrical connection

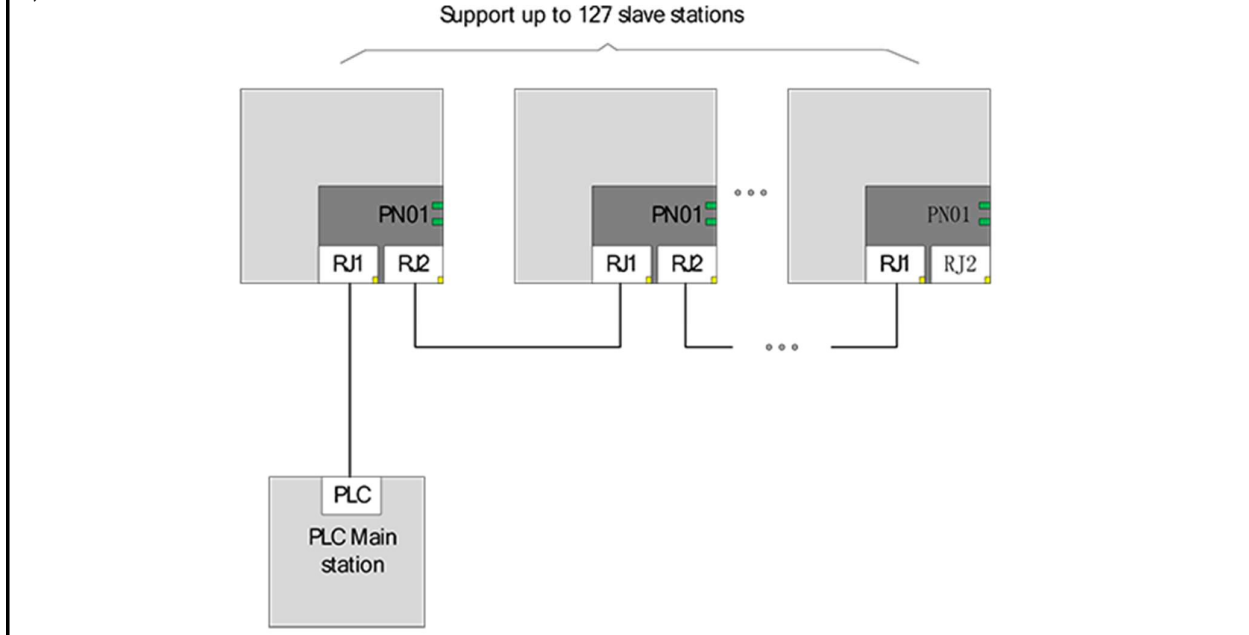

4. Status indicator description

PN01 expansion card can track bus communication failures through 2 status indicators. The diagnosis failure description is shown in the following table:

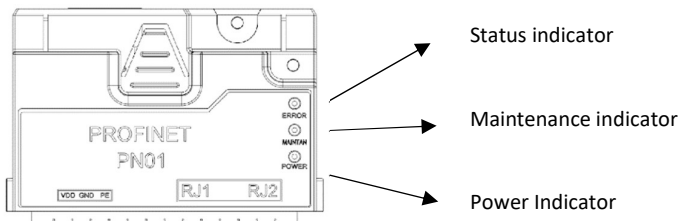

Indicator light	Color	Status description
ERROR	Red light is always on	Expansion card failure
	Red light is off	Communication is normal

MAINTAN	Red light is always on	Expansion card failure
	Red light is off	Communication is normal
POWER	Green light is always on	The expansion card is powered on normally
	Red light is off	The power supply of the expansion card is abnormal or the inverter is not powered on

5. Related Parameters

5.1 Parameter List

Parameter Number	Parameter Name	Comments
1000	Device Name	The device name, SSI-PNIO-xxxxx, this parameter represents the value of xxxxx. E.g,1 represents the device name is SSI-PN-00001
1001	IP Address[0]	IP address. E.g,192.168.0.1 set the following parameters : 1001: 192, 1002: 168, 1003: 0, 1004:1
1002	IP Address[1]	
1003	IP Address[2]	
1004	IP Address[3]	
1005	IP Address Mask[0]	IP address mask. E.g,255.255.255.0 set the following parameters : 1005 : 255, 1006 : 255, 1007 : 255, 1008 : 0
1006	IP Address Mask[1]	
1007	IP Address Mask[2]	
1008	IP Address Mask[3]	
1009	Gateway address[0]	Gateway address. E.g,192.168.0.241 set the following parameters : 1009 : 192, 1010 : 168, 1011 : 0, 1012 : 241
1010	Gateway address[1]	
1011	Gateway address[2]	
1012	Gateway address[3]	
1020	Fault Word	Error code. Not currently supported, reserve parameters.
1021	Warning Word	Warning code. Not currently supported, reserve parameters.
1030	Read PCD 1	Periodically read parameter configuration. The first parameter defaults to the status word, and the second parameter defaults to the actual value. The third word and other words after it can be configured through the Read PCD parameter. E, g, if you need to read parameters P0-50, P0-51 can be configured to read PCD 1 (P10-30) as 50 and Read PCD 2 (P10-31) as 51. Note that it needs to be used in conjunction with PPO Type.
1031	Read PCD 2	
1032	Read PCD 3	
1033	Read PCD 4	
1034	Read PCD 5	
1035	Read PCD 6	
1036	Read PCD 7	
1037	Read PCD 8	
1040	Write PCD 1	Periodically write parameter configuration. The first parameter of periodic write parameters is Control word, and the second parameter is Reference (target reference value). If you need to write parameters P0-51, P0-52; you need to configure Write PCD 1 (P10-40)) to 51 and Write PCD 2 (P10-41) to 52. Note that it needs to be used in conjunction with PPO Type.
1041	Write PCD 2	
1042	Write PCD 3	
1043	Write PCD 4	
1044	Write PCD 5	
1045	Write PCD 6	
1046	Write PCD 7	
1047	Write PCD 8	

5.2 Control words and Status words

PPO type (Telegram type)

Standard Telegram 1	2 words In(Read) Status Word Actual Value	2 words Out(Write) Control Word Setpoint
PPO Type 3	2 words In(Read) Status Word Actual Value	2 words Out(Write) Control Word Setpoint
PPO Type 4	4 words In(Read) Status Word Actual Value Read PCD 1 Read PCD 2 Write PCD 2	4 words Out(Write) Control Word Setpoint Write PCD 1
PPO Type 6	6 words In(Read) Status Word Actual Value Read PCD 1 Read PCD 2 Read PCD 3 Read PCD 4	6 words Out(Write) Control Word Setpoint Write PCD 1 Write PCD 2 Write PCD 3 Write PCD 4
PPO Type 7	8 words In(Read) Status Word Actual Value Read PCD 1 Read PCD 2 Read PCD 3 Read PCD 4 Read PCD 5	8 words Out(Write) Control Word Setpoint Write PCD 1 Write PCD 2 Write PCD 3 Write PCD 4 Write PCD 5

	Read PCD 6	Write PCD 6
PPO Type 8	10 words In(Read) Status Word Actual Value Read PCD 1 Read PCD 2 Read PCD 3 Read PCD 4 Read PCD 5 Read PCD 6 Read PCD 7 Read PCD 8	10 words Out(Write) Control Word Setpoint Write PCD 1 Write PCD 2 Write PCD 3 Write PCD 4 Write PCD 5 Write PCD 6 Write PCD 7 Write PCD 8

P9-02 Status word correspondence table		
Bit	0	1
bit0	Control not ready	Control ready
bit1	Control not ready	Control ready
bit2	Inertial stop	Run
bit3	Fault-free	Fault tripping
bit4	Fault-free	The fault is not tripped
bit5	Reserve	Reserve
bit6	Fault-free	Fault tripping
bit7	No warnings	Warning
bit8	does not Run by reference value	Run by reference value
bit9	Manual mode	Remote control
bit10	Frequency out of range	Frequency in the range
bit11	Stop	Run
bit12	Reserve	Reserve
bit13	Within the voltage range	Over voltage limit
bit14	Reserve	Reserve
bit15	No overheat warning	Overheat warning

6. GSD file configuration

When using the PROFIBUS master station, you must first configure the GSD file of the slave station so that the corresponding slave station equipment is added to the system of the master station. GSD files can be obtained from suppliers or manufacturers.

Take S7-300 as an example:

Step1 : Chose Option/Manage general station description files(GSD), Install SSI GSDML ;

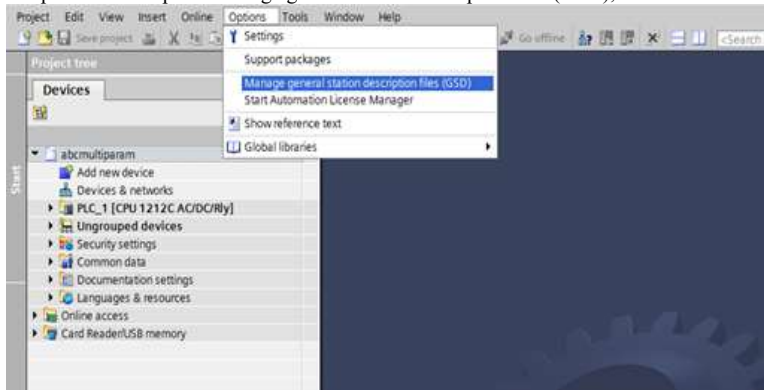

Step 2 : Browse to the path where the GSDML file is located and click install.

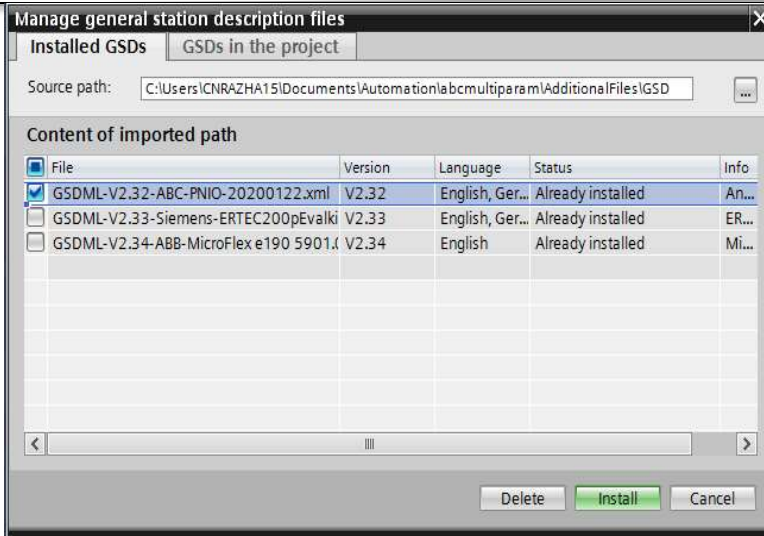

7. Periodic communication setting guide

Set the inverter parameters according to the example project configuration, IP: 192.168.0.21; IP Address Mask:255.255.255.0; Gateway:192.168.0.241; Device Name:1; Example project configuration PPO Type 6, 6 words in and 6 words out. Need to set inverter configuration parameters:

- P10-30 Read PCD 1: P0-51; need to set P10-30=51
- P10-31 Read PCD 2: P0-52; need to set P10-30=51
- P10-32 Read PCD 3: P0-54, need to set P10-30=51
- P10-33 Read PCD 4: P0-55; need to set P10-30=51
- P10-40 write PCD 1: 057; need to set P10-40=57
- P10-41 write PCD 2: 058; need to set P10-41=58
- P10-42 write PCD 3: 060, need to set P10-42=60
- P10-43 write PCD 4: 061. need to set P10-43=61

Step 2: Restart the device.

Step3: Compile and download the project to the PLC. If the current PLC URL is not in a network segment, just follow the prompts.

Siemens PLC manual has detailed instructions.

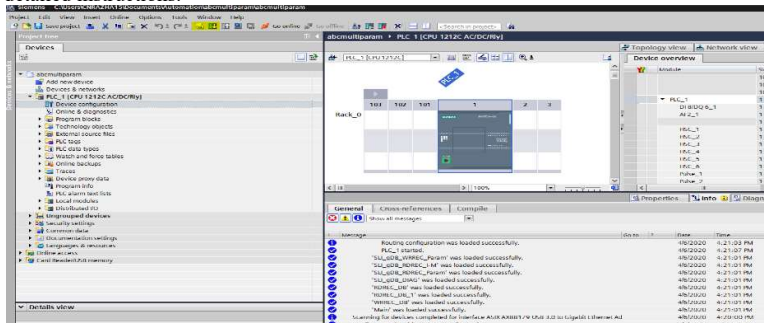

Step 4: Select PLC and click Go Online to enter online mode. Confirm that there is no error message, as shown below:

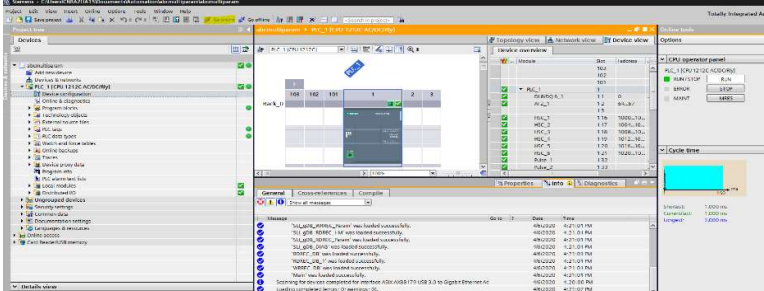

Step 5: Enter the monitoring variable interface and change the control word (QW1) and reference value (QW2). And click the force

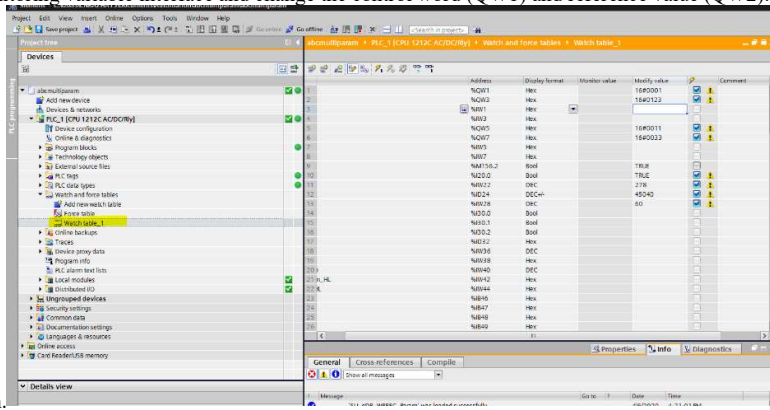

button.

Step 6: Change the control word (QW1) to 1, and the reference value (QW2) to 123. And click the force button. As shown in the figure below: Verify that the status word (IW1) is 0f07 and the current value (IW2) is 123.

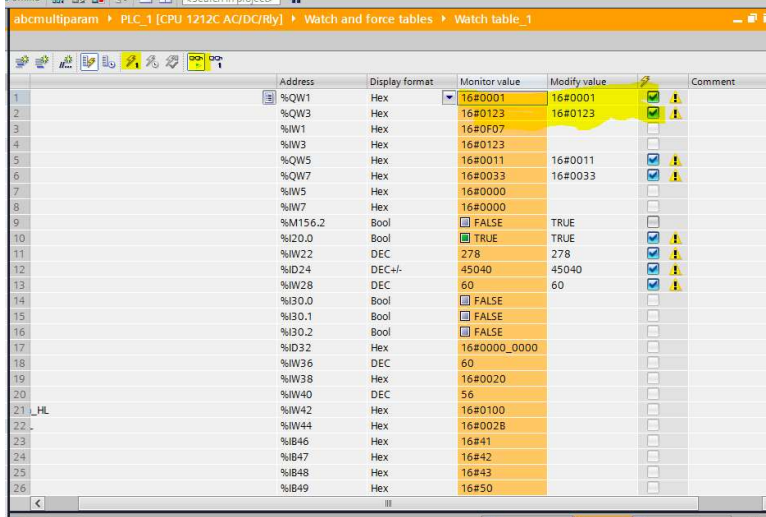

Step 7: Change the control word (QW1) to 0, and click the force button. As shown in the figure below: Verify that the status word (IW1) is 0203 and the current value (IW2) is 0.

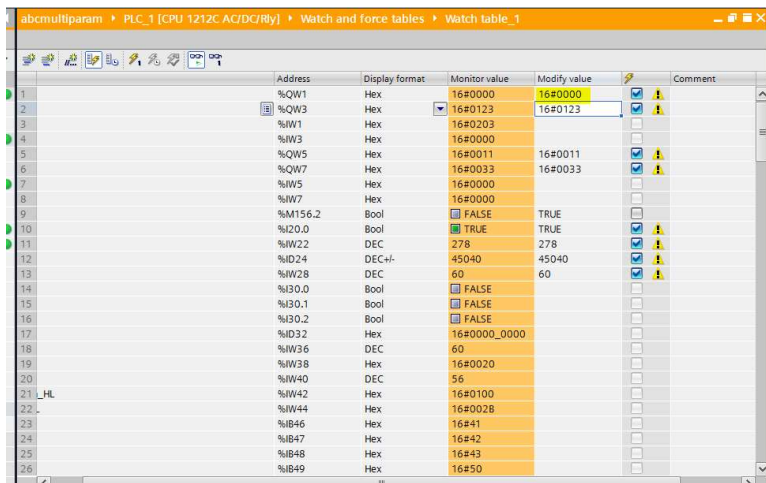

Step8 : Verify Write PCD 1, Write PCD 2, Write PCD 3, Write PCD 4, Read PCD 1, Read PCD 2, Read PCD 3, Read PCD 4. Modify the parameters 051:300, 052:302, 054:303; 055:304, and verify the actual reading value as shown in the figure. Modify QW5, QW7, QW9, QW11 to the values shown in the figure below, and force the variables, read the inverter parameters 057, 058, 060, 061 to verify that they are the values shown in the figure.

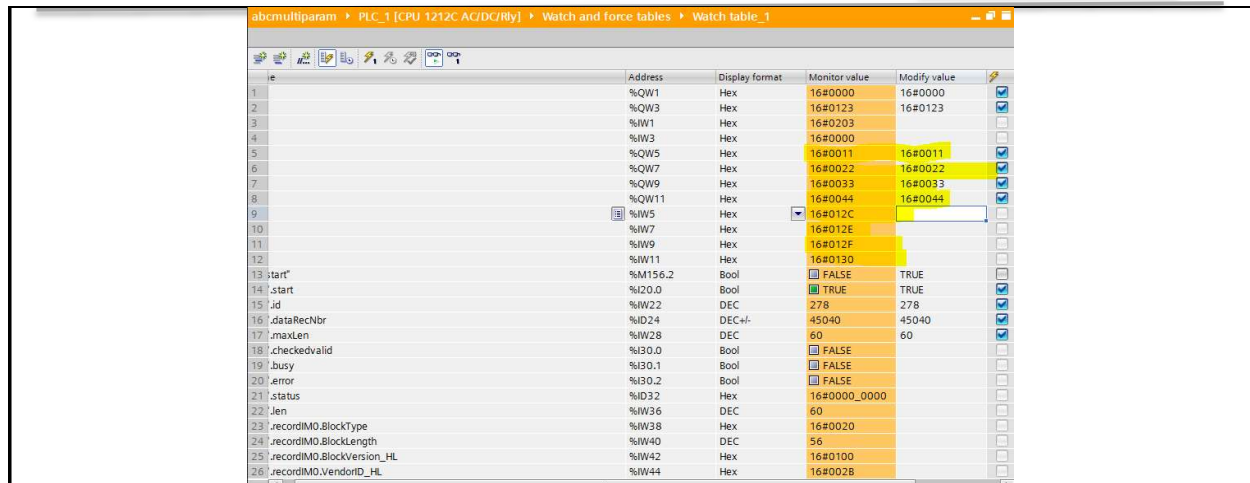

Step9: Test other message types according to the PPO types listed in Appendix 1 and Appendix 2 and the corresponding parameters of PCD. To change the PPO type, you need to re-modify the program, delete PPO6 as shown in the figure below, and add other PPO types. The test method is similar.

8. Fault description and disposal

Type	ERROR	MAINTAN	POWER	Corresponding measures
1	Red light on	X	X	Internal fault
2	X	Red light on	X	Internal fault
3	X	X	Green light on	PN01 power supply is normal
4	X	X	Green light off	PN01 power supply is abnormal or not powered on

Note: When the relevant parameters are set, but the PLC and communication still cannot be connected, please use the command to directly PIN the corresponding IP address of the inverter. If successfully PIN, it means that the inverter parameters are set correctly.

SOLAR DRIVE FOR PUMP WITH SSI800

1.Applications



Irrigation



Fishing Farming



Live Stock



Swimming Pool



Domestic Water Supply



Fountain

2.Supporting System

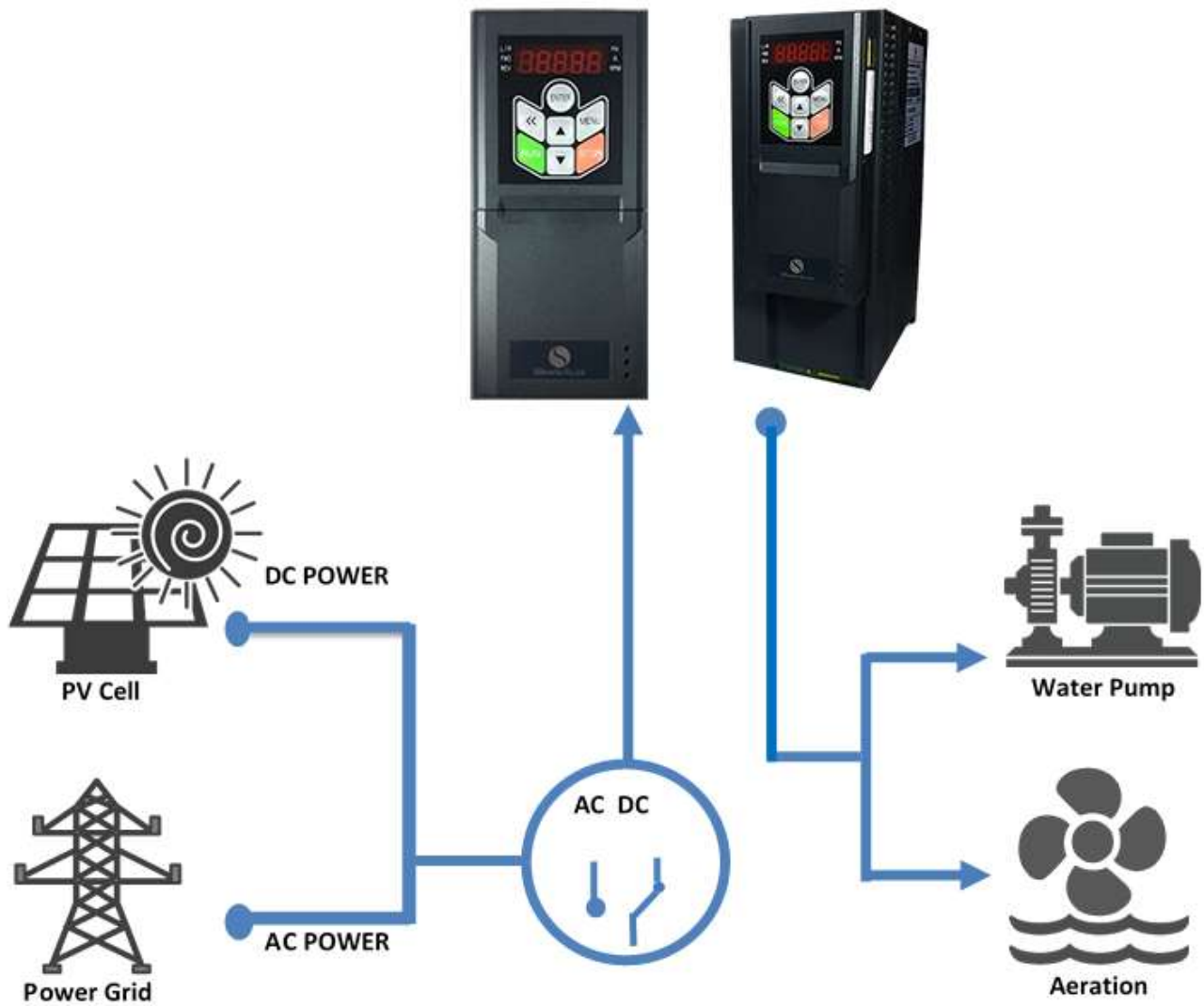

3. Special Features for Solar Pump

- Built-in MPPT (maximum power point tracking), maximizes your power output
- Support both AC input (single phase or three phases) from Grid and DC input from PV
- Wide DC voltage range from 120Vdc to 750Vdc
- Automatic Start and Stop according to sunrise and sunset
- Auto recover from Power cuts
- Built-in Protection functions including dry run, over pressure etc.
- control compatible with auto start/stop etc.
- Customized functions possible to fulfill your special demands

4. Technical Specifications

Item		Specification
Line in	Voltage	200V type: AC 200~240V -15%~+10%, DC 120V~380V 400V type: AC 380~480V -15%~+10% ; DC 250V~760V
Out put	Voltage	0~100% Line in voltage or 0 ~ DC Voltage/1.414
Main Control	Control algorithm	V/F control, Vector Control
	Motor Type	IM, SPM, IPM
	Overload	Heavy load type: 150% 60s, 180% 3s Light load type: 120% 60s, 150% 3s
	Switching Frequency	2k~16kHz ;
Basic Functions	Process close loop, torque control (with/without speed sensor), Motor auto tuning, Load compensation, auto DC voltage regulation, DC brake/AC brake, speed limit, current/torque limit, fly start, KEB etc.	
Protection Functions	Short circuit, Ground fault, line phase loss, under voltage, over voltage, over current, overload, over temperature, motor thermal protection, motor phase loss, control wire broken etc.	
Control terminals	RUN, F/R, DI1, DI2, DI3, DI4	Digital inputs: Input type: NPN/PNP
	DO1	Digital Output: Open Collector; 0~40mA; 0~30V;
	RS+, RS-	RS485 Communication: Max Baud Rate: 38400bit/s;
	FA-FB-FC KA-KB	Relay Output: Resistive Load: 250VAC 3A/30VDC 3A ; Inductive Load: 250VAC 0.2A/24VDC 0.1A (cosφ=0.4) ;
	AI1, AI2	Analogue Inputs: 0~10V/ 0~20mA;
	AO1	Analogue Output: 0~10V or 0~20mA
	VDD	24V Power Supply: Max 200mA
	+10V	10V signal power supply: Max 10mA
	GND	Signal Ground
	PE	Safety Ground
Operation Environment	Protection Level	IP20 ;
	Operation Ambient Temperature	Operating range: -10°C ~ 60°C As heavy load type: Nominal current to 50°C, derate from 50°C As light load type: Nominal current to 40°C, derate from 40°C
	Operation Ambient Humidity	5%~85% (No condensing at 95%) ;
	Vibration	1.14g ;
	Altitude	1000m, derate from 1000m
	Motor cable length	Shielded Cable: 50m ; Un-shielded cable:100m

5. Main Parameters and description

Parameters	Name	Value Range	Default	Remark
P0-03	App Function	0: no function 1: PUMP	0	
P2-05~P2-10	DIx	64: PUMP start		
P20-00	PUMP Mode	0: pressure mode 3: solar MPPT Mode3	0	
P20-01	Min reference	0.00~100.00%	40.0	%
P20-02	Max reference	0.00~100.00%	100.0	%
P20-10	Minimum DC Bus Voltage for MPPT	50~800	220V: 100 380V: 250	V
P20-11	Maximum DC Bus Voltage for MPPT	50~800	220V: 365 380V: 600	V
P20-12	Object DC voltage tracker interval time	0.1~100.0	8.0	S
P20-13	Maximum DC voltage search step	0.01~20.00%	10.0	%
P20-14	Minimum DC voltage search step	0.01~10.00%	0.2	%
P20-15	Start Delay time	1~6000	240	S

- P20-00: Solar MPPT Mode select. Mode3 is the new algorithm which is different from mode1/2 and the former mode3.
- P20-01 / P20-02: MPPT min reference and MPPT max reference. unit: %,100%=P0-16
- P20-10 / P20-11:
DC voltage < P20-10 - 15: inverter stop and can't be start;
DC voltage < P20-10 and >=P2-10 - 15: output frequency will reduce to P20-01 when inverter is running, else inverter will keep stop state;
DC voltage > P20-11: output frequency will increase to P20-02
- P20-12: object DC voltage tracker interval time.
- P20-13/P20-14: P20-13 is maximum DC voltage search step. it calculate by formula: (P20-11 – P20-10)*P20-13
P20-14 is minimum DC voltage search step. it calculate by formula: (P20-11 – P20-10)*P20-14
Example: if P20-11=650V, P20-10=350V,P20-13=3.00(3%).P20-14=1.00(1%).then maximum DC voltage search step=(650-350)*3%=9V,
minimum DC voltage search step=(650-350)*1%=3V
- P20-15: If inverter is stop state, it will wait for DC voltage >=P20-10+15, then after P20-15 second, inverter will start run again.

6.Type code

Model Type	Power (kW)	Voltage (V)	Heavy Load		Light Load		Air (m3/h)
			Input (A)	Output (A)	Input (A)	Output (A)	
SSI800-2S0R37GB-PU00	0.37	1×200-240	6.5	2.5	-	-	17.2
SSI800-2S0R75GB-PU00	0.75	1×200-240	9.3	4.5	-	-	17.2
SSI800-2S1R5GB-PU00	1.5	1×200-240	15.5	7.5	-	-	17.2
SSI800-2S2R2GB-PU00	2.2	1×200-240	23	9.6	-	-	45.5
SSI800-2S4R0GB-PU00	4.0	1×200-240	33	16	-	-	90
SSI800-4T0R7GB /1R5GB-PU00	0.75/1.5	3×380-440	3.7	2.3	5.8	3.7	17.2
		3×440-480	3.2	2.1	5.0	3.4	
SSI800-4T1R5GB/2R2PB-PU00	1.5/2.2	3×380-440	6	3.8	8.5	5.3	17.2
		3×440-480	5.2	3.5	7.3	4.8	
SSI800-4T2R2GB/3R7PB -PU00	2.2/4.0	3×380-440	8.5	5.3	14.0	8.5	17.2
		3×440-480	7.3	4.8	12.4	8.2	
SSI800-4T3R7GB/5R5PB -PU00	4.0/5.5	3×380-440	15	9.6	18.6	11.2	45.5
		3×440-480	12.9	8.8	18.1	11.0	
SSI800-4T5R5GB/7R5PB -PU00	5.5/7.5	3×380-440	20.8	13.0	24.7	15.5	90
		3×440-480	19.1	11.8	21.4	14.2	
SSI800-4T7R5GB/011PB -PU00	7.5/11	3×380-440	27.1	17.0	33.1	22.0	90
		3×440-480	23.4	15.5	30.2	21.0	
SSI800-4T011GB/015PB-PU00	11/15	3×380-440	35.9	25.0	42.5	31.0	124
		3×440-480	31.4	22.7	39.8	28.5	
SSI800-4T015GB/018R5PB-PU00	15/18.5	3×380-440	43.4	32.0	50.2	36.0	170
		3×440-480	40.2	29.1	45.8	34.0	
SSI800-4T018R5GB/022PB-PU00	18.5/22	3×380-440	51.5	38.0	58.5	42.5	230
		3×440-480	46.1	34.5	54.0	40.0	
SSI800-4T022GB/030PB-PU00	22/30	3×380-440	61	45.0	79.0	56.0	272
		3×440-480	54.5	40.9	73.0	51.0	
SSI800-4T030G/037P-PU00	30/37	3×380-440	82.5	61.0	98.0	71.0	303
		3×440-480	74	52.0	90.0	65.0	
SSI800-4T037G/045P-PU00	37/45	3×380-440	72	75.0	87.0	90.0	374
		3×440-480	65	68.0	79.0	80.0	
SSI800-4T045G/055P-PU00	45/55	3×380-440	88	91.0	102.0	104	408
		3×440-480	80	82.0	99.0	101	
SSI800-4T055G/075LP-PU00	55/75	3×380-440	110	112	142	145	476
		3×440-480	100	102	132	136	
SSI800-4T075G/090P-PU00	75/90	3×380-440	148	150	170	175	595
		3×440-480	135	140	150	155	
SSI800-4T090G/110P-PU00	90/110	3×380-440	175	180	192	202	646
		3×440-480	155	160	172	179	
SSI800-4T110G/132P-PU00	110/132	3×380-440	206	215	245	255	714
		3×440-480	183	190	225	235	
SSI800-4T132G/160P-PU00	132/160	3×380-440	251	260	290	305	850
		3×440-480	231	240	285	295	
SSI800-4T160H/185L-PU00	160/185	3×380-440	304	315	334	350	1029
		3×440-480	291	302	307	322	
SSI800-4T185G/200P-PU00	185/200	3×380-440	350	365	370	385	1190
		3×440-480	320	335	336	352	
SSI800-4T200G/220P-PU00	200/220	3×380-440	381	395	409	425	1292
		3×440-480	348	361	375	390	
SSI800-4T220G/250P-PU00	220/250	3×380-440	420	435	453	461	1411
		3×440-480	383	398	419	425	
SSI800-4T250G/280P-PU00	250/280	3×380-440	472	480	509	525	1564
		3×440-480	436	443	461	478	

SSI800-4T280G/315P-PU00	280/315	3×380-440	525	540	568	585	1700
		3×440-480	475	490	510	522	
SSI800-4T315G/355P-PU00	315/355	3×380-440	590	605	621	634	1870
		3×440-480	531	540	557	566	
SSI800-4T355G/415P-PU00	355/415	3×380-440	647	660	694	725	2125
		3×440-480	580	590	628	655	
SSI800-4T415G/450P-PU00	415/450	3×380-440	718	745	776	805	2380
		3×440-480	653	678	708	735	

7. Basic user steps

- Set P0-03=1 and P20-00=3 (enable solar MPPT Mode3).
- Set one DI terminal function (P2-05~P2-10) to 64
- Set parameters P20-01/P20-02/P20-10~P20-15 based on application request.
- Ensure Drive is in remote mode, if not, please set P6-31=0 (change to remote mode). set DI terminal (which function set to 64) to active, then solar MPPT function start running.

8. Introduction of MPPT Mode 3

For MPPT mode3, we are trying to find the optimal DC input voltage(from PV plant) which output maximum power, we design a DC voltage controller to control the dc voltage around the optimal DC voltage.

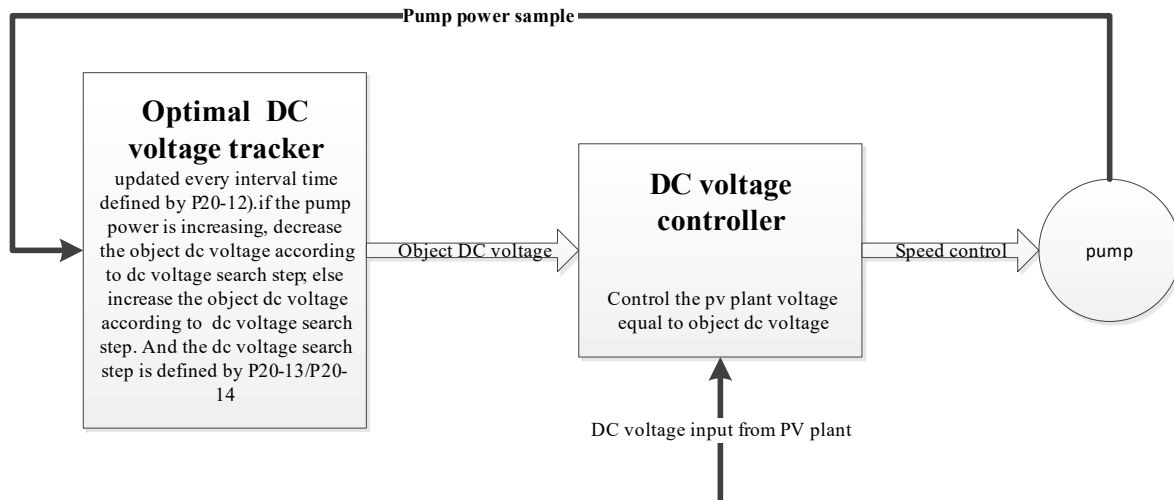

The theory of MPPT mode3

Instruction of MPPT Mode3 parameters adjust

- P20-01 and P20-02: Usually we set P20-02=100% (50HZ). For P20-01 the default value is 40% (20HZ), in case of PV plant power is faint, the inverter will trip or sleep when ramp up to 20HZ (For example, in the morning and evening if the PV plant open circuit voltage is higher P20-11, but the power is faint, possible the PV plant can only drive the pump to 10HZ. If we run pump ramp up to 20HZ, PV plant voltage will drop immediately when pump reach to 10HZ). If P20-01 is too large, maybe PV plant can't be drive it reach to P20-01. But another side, if P20-01 is too low, and the pump can't draw water, it depends on the pump. Consider these two sides, we suggest the customer first find out the minimum frequency which the pump can draw water, then set P20-01 according to this minimum frequency.
- P20-10 and P20-11: We need to ensure that the PV plant maximum power voltage (all working time) in the range of P20-10 to P20-11 (P20-10 < PV plant maximum power voltage < P20-11). As we know that the algorithm mode3 is finding out the optimal DC voltage which output maximum power, and the search range is P20-10 to P20-11. If maximum power voltage in some working time out of this range. Algorithm can't find out the optimal point, and it will cause the inverter run unstable (For example, set P20-11=580V, if the maximum power voltage is about 600V at 1 o'clock p.m. then the inverter will run under big frequency ripple continuously, the inverter needs to control the DC voltage <=580V, but the maximum power voltage is about 600V, if DC voltage <=600V the DC voltage will drop fast, so the inverter will report under voltage. If we adjust P20-11=650V, the inverter will run stable and the DC voltage will stable around 600V). About P20-11, we suggest: P20-11 is 20V higher PV plant maximum power voltage (consider best sunshine working time), it means P20-11=20+ PV plant maximum power voltage (best sunshine). If we don't know the maximum power voltage (best sunshine), then we can set P20-11 >= PV plant open circuit voltage.
For P20-10, we suggest to set P20-10 is 50V lower than PV plant maximum power voltage (consider the worst sunshine working time: in the morning or evening, especially under the cloudy and rain weather), it means P20-10 = PV plant maximum power voltage (worst sunshine) - 50. If we don't know the maximum power voltage (worst sunshine), then we can set P20-11 = (50% ~60%) * PV plant open circuit voltage.

- P20-13 and P20-14: P20-13 is the maximum DC voltage search step, P20-14 is the minimum DC voltage search step. We suggest to set P20-13 maximum DC voltage search step = 5V to 10V (the customer need to convert to percent, for example: if the customer would like to set the maximum DC voltage search step = 6V, then $P20-13 = 6V / (P20-11 - P20-10)$; the minimum DC voltage search step P20-14 = 1V to 3V same as P20-13, the customer must convert to percent, then set it to P20-14).
- P20-12 : P20-12 is the object DC voltage tracker interval time, we will calculate the output power in the interval time (set by P20-12), then judge the output power change trend to decide decrease or increase the object DC voltage. If we set P20-12 too short, then the object DC voltage will change fast, it will cause the DC voltage unstable. If we set P20-12 long, it is not suitable for tracking the max power point. We suggest to set P20-12 = 1.0S to 4.0S.
- P0-51 and P0-52: If the inverter's output power exceed the maximum power point of the solar battery, then the solar battery DC voltage will drop fast. If we need to control the inverter output power around solar battery maximum power point rippling, we should be set the frequency ramp down time(P0-52) short enough, otherwise, if the maximum power point of the solar cell drops rapidly, the weather suddenly has a cloudy day, and the slope of the inverter does not fall fast enough, then inverter will report under voltage error or enter sleep state. Method of setting P0-52, It is mainly based on the electrical performance of solar cells (the dc voltage drop how fast when output power over the maximum power point) and pump inertia. On the other hand, the ramp up time (P0-51) can't be set fast, otherwise it will cause big frequency ripple range, so we suggest customer set P0-51= 30S to 80S, P0-52= 1S to 5S.

It is recommended that customers set the relevant parameters of the solar pump as follows:

P0-02=0(V/F control)

P0-03=1

P0-51 \geq 50.0S

P0-52=0.5S to 5.0S(first you can try 5.0, if inverter show under voltage warning, please decrease it until it is ok)

P1-55= 120V (380V inverter)/70V (220V inverter)

P1-56=25.0HZ

P2-05=64 (Connect Run command signal to FWD terminal)

P20-00=3(MPPT Mode3)

P20-01=40.00% (minimum frequency 20HZ)

P20-02=100.00% (maximum frequency 50HZ)

P20-10=350V (380V inverter)/180V (220V inverter)

P20-11=650V (380V inverter)/350V (220V inverter)

P20-12=2.0S

P20-13=3.0%

P20-14=1.0%

P20-15=20.0S

